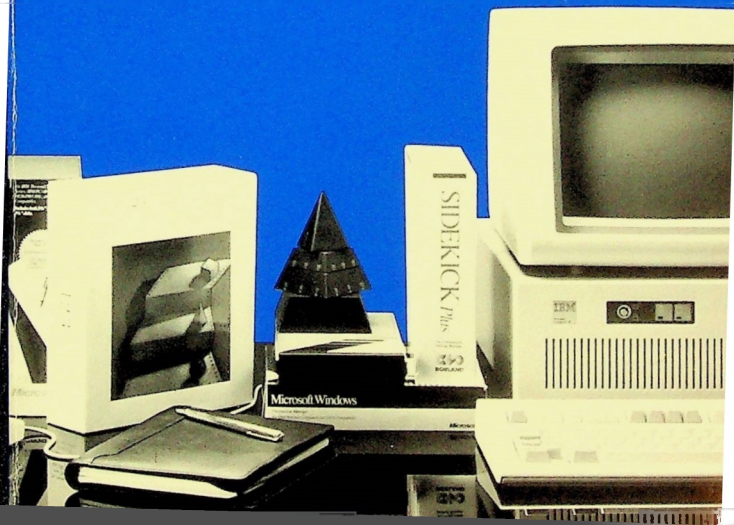


intel

The **Installation Guide**  
helps you quickly put the  
**Intel<sup>®</sup> Above<sup>™</sup> Board**  
**Plus 8 and Plus 8 I/O**  
to work.



---

## FCC COMPLIANCE STATEMENT

The Above Board Plus 8 I/O generates and uses energy of about the same frequency as radio and TV broadcasts. Installed incorrectly, it may interfere with reception of radio and TV broadcasts.

The board has been certified to be within energy emission limits for Class B computing devices as defined in the FCC Rules, Part 15, Subpart J. Installed correctly, it probably will not interfere with your radio or TV. However we do not guarantee the absence of interference.

Only peripherals (computer input/output devices, terminals, printers, etc.) certified to comply with the Class B limits may be attached to this board. Operation with non-certified peripherals is likely to result in interference with radio and TV reception. NOTE: shielded, grounded cables must be used.

If you suspect this board is causing interference, turn your computer on and off while your radio or TV is showing interference. If the interference disappears when you turn the computer off and reappears when you turn the computer on, something in the computer is causing interference.

To reduce interference, try these suggestions:

- Change the direction of the radio or TV antenna.
- Move the computer or the radio or the TV. For example, if the computer is to the right of the TV, move it to the left of the TV. Or, move the computer farther away from the radio or TV.
- Plug the computer into a different outlet. Don't plug your radio or TV into the same circuit as your computer's.
- Ensure that all expansion slots (on the back or side of the computer) are covered. Also, ensure that all metal retaining brackets are tightly attached to the computer.

If these suggestions don't help, consult your computer dealer or an experienced radio/TV technician for more suggestions. You might find the following booklet helpful:

"How to Identify and Resolve Radio-TV Interference Problems"

You can order the booklet from the U.S. Government Printing Office, Washington, D.C. 20402. Ask for stock number 004-000-00345-4.

---

**BESHEINIGUNG DES  
HERSTELLERS/IMPORTEURS**

Hiermit wird bescheinigt, daß der/die/das

Above Board Plus 8 I/O

(Gerät, Typ, Bezeichnung)

in Übereinstimmung mit den Bestimmungen der

Vfg 1046/84

(Amtblattverfügung)

funk-enstört ist.

Der Deutschen Bundespost wurde das Inverkehrbringen dieses Gerätes angezeigt und die Berechtigung zur Überprüfung der Serie auf Einhaltung der Bestimmungen eingeräumt.

Intel Corporation

Name des Herstellers/Importeurs

---

## FCC COMPLIANCE STATEMENT

The Above Board Plus 8 generates and uses energy of about the same frequency as radio and TV broadcasts. Installed incorrectly, it may interfere with reception of radio and TV broadcasts.

The board has been verified to be within energy limits for Class B computing devices as defined in the FCC Rules, Part 15, Subpart J. Installed correctly, it probably will not interfere with your radio or TV. However, we do not guarantee the absence of interference.

Only peripherals (computer input/output devices, terminals, printers, etc.) certified to comply with the Class B limits may be attached to this board. Operation with non-certified peripherals is likely to result in interference with radio and TV reception. NOTE: shielded, grounded cables must be used.

If you suspect this board is causing interference, turn your computer on and off while your radio or TV is showing interference. If the interference disappears when you turn the computer off and reappears when you turn the computer on, something in the computer is causing interference.

To reduce interference, try these suggestions:

- Change the direction of the radio or TV antenna.
- Move the computer or the radio or the TV. For example, if the computer is to the right of the TV, move it to the left of the TV. Or, move the computer farther away from the radio or TV.
- Plug the computer into a different outlet. Don't plug your radio or TV into the same circuit as your computer's.
- Ensure that all expansion slots (on the back or side of the computer) are covered. Also, ensure that all metal retaining brackets are tightly attached to the computer.

If these suggestions don't help, consult your computer dealer or an experienced radio/TV technician for more suggestions. You might find the following book helpful:

"How to Identify and Resolve Radio-TV Interference Problems"

You can order the booklet from the U.S. Government Printing Office, Washington, D.C. 20402. Ask for stock number 004-000-00345-4.

---

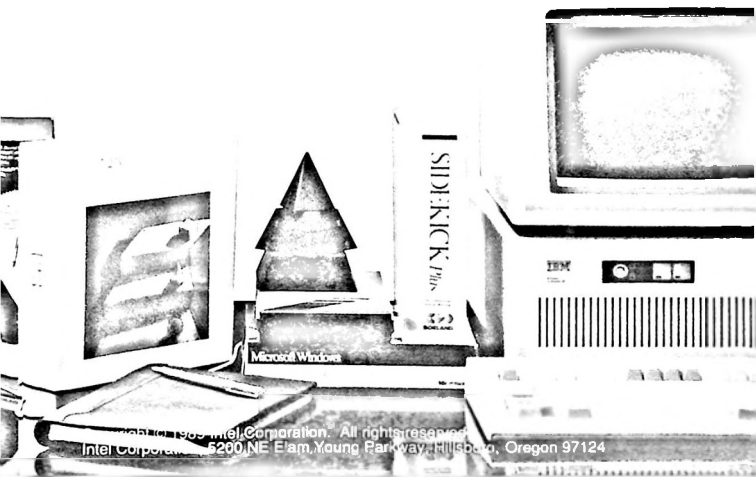
**CANADIAN DEPARTMENT OF  
COMMUNICATIONS COMPLIANCE  
STATEMENT**

This digital apparatus does not exceed the Class B limits for radio noise emissions from digital apparatus set out in the Radio Interference Regulation of the Canadian Department of Communications, CRC c.1374.

---



# Above™ Board Plus 8 and Plus 8 I/O Installation Guide



---

First edition May 1989

Intel Corporation assumes no responsibility for errors that may appear in this manual. Nor does Intel make any commitment to update the information contained in this manual.

Intel, Above, and Inboard are trademarks of Intel Corporation. Other brand and product names are trademarks of their respective owners.

---

# Contents



## How to Save Time Using This Book

For experts . . . . .	1-2
For everyone else . . . . .	1-2



## Product Overview

Which Above Board do I have? . . . . .	2-2
Three kinds of memory . . . . .	2-4
Conventional memory . . . . .	2-5
Expanded memory . . . . .	2-6
Extended memory . . . . .	2-6
A summary of Above Board features and benefits . . . . .	2-7
Hardware features . . . . .	2-7
Software features . . . . .	2-9



## Installation Overview



## Adding Memory to the Above™ Board

Is your board already full? . . . . .	4-2
Selecting the memory chips . . . . .	4-4
Adding the memory chips . . . . .	4-5



## The Hardware Worksheet



## Inserting the Above™ Board in Your Computer

Inserting the Above Board in an IBM AT or compatible computer . . . . .	6-2
Inserting the Above Board in an IBM PC, XT, or compatible computer . . . . .	6-12



Inserting the Above Board in an IBM PS/2 Model 30 or Model 30 286 . . . . .	6-20
--	------

**7**

## Running SETBOARD

What SETBOARD does . . . . .	7-2
Before you use SETBOARD . . . . .	7-3
Using SETBOARD . . . . .	7-3
Starting SETBOARD . . . . .	7-4
The different paths through SETBOARD . . . . .	7-4
Completing the information on the Hardware Worksheet . . . . .	7-6
Special notes about SETBOARD . . . . .	7-7
After running SETBOARD . . . . .	7-8
For IBM PC or compatible computers . . . . .	7-8

**8**

## Running The IBM AT and Compatible Computer's Setup Program

What's the setup program? . . . . .	8-2
When to run setup . . . . .	8-2
Starting setup for an IBM AT . . . . .	8-3
Starting setup for a COMPAQ . . . . .	8-3
Starting setup for compatible computers . . . . .	8-3
What to tell setup . . . . .	8-3
Example 1 -- for DOS users who don't use VDISK . . . . .	8-4
Example 2 -- for DOS users who use VDISK . . . . .	8-5
Example 3 -- for XENIX and OS/2 users . . . . .	8-5
Where to go from here . . . . .	8-6

**9**

## Running TESTAB

Before you begin . . . . .	9-2
Starting the confidence tests . . . . .	9-3



## Running SOFTSET

What does SOFTSET do? . . . . .	10-2
Before you use SOFTSET . . . . .	10-3
Requirements . . . . .	10-4
Where to install the Above Board software . . . . .	10-4
Check the date on the Above Board software diskette . . . . .	10-4
Back up the Above Board software . . . . .	10-5
Remove any data in a print buffer or RAM disk . . . . .	10-5
Starting SOFTSET . . . . .	10-5



## Running CHKMEM

Starting CHKMEM . . . . .	11-2
If the results aren't what you expected . . . . .	11-2



## Ram Disks

What's a RAM disk? . . . . .	12-2
Differences between ordinary disks and RAM disks . . . . .	12-2
When is a RAM disk useful? . . . . .	12-4
When is a RAM disk not useful? . . . . .	12-6
Using Above Board RAM disks with VDISK RAM disks . . . . .	12-7
Assigning a drive letter to a RAM disk . . . . .	12-8
Copying files to a RAM disk . . . . .	12-9



## Print Buffer

What is a print buffer? . . . . .	13-2
When is a print buffer useful . . . . .	13-2
When is a print buffer not useful? . . . . .	13-3
Controlling the printer -- the print buffer command menu . . . . .	13-4
Assigning the print buffer to a printer . . . . .	13-10
Buffering serial printers . . . . .	13-11
Handling messages . . . . .	13-11
Messages . . . . .	13-11
Print Buffer Msg 500 . . . . .	13-11

---

Print Buffer Msg 507 . . . . .	13-12
--------------------------------	-------

**14**







## Parallel Port

What is a parallel port? . . . . .	14-2
Is your printer parallel? . . . . .	14-3
Buying a cable . . . . .	14-3
Connecting the printer . . . . .	14-3
Naming or disabling the parallel port . . . . .	14-4
Using your printer . . . . .	14-6
Printing from an application program . . . . .	14-6
Printing an ASCII file . . . . .	14-6

**15**

## Serial Port

What is a serial port? . . . . .	15-2
The serial port on the Above Board Plus 8 I/O . . . . .	15-2
Naming serial ports . . . . .	15-3
Using a serial printer . . . . .	15-4
Letting your application program set up the serial port . . . . .	15-5
Setting up the serial port yourself . . . . .	15-5
Fooling some application programs . . . . .	15-6
Communication with other computers . . . . .	15-7
Connector for the serial port . . . . .	15-8

- 
-  Putting A Chip in a Socket
  -  Troubleshooting
  -  Multiple Above™ Boards in One Computer
  -  Technical Information
  -  Mapping Conventional Memory
  -  Manually Installing the Above™ Board Software

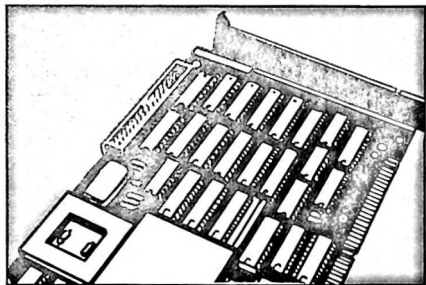
Glossary

Index

Five Year Limited Warranty

Software License Agreement

# How To Save Time Using This Book



## Chapter 1

1

---

## HOW TO SAVE TIME USING THIS BOOK

If you're in a hurry to use the Above Board Plus 8 or Plus 8 I/O, reading this chapter can save you time. It tells you the sections of the manual you can skip, so you can focus on the information you need.

This manual refers to the Above Board Plus 8 and Plus 8 I/O as the Above Board. When further distinction is necessary, the text refers explicitly to the Above Board Plus 8 or the Above Board Plus 8 I/O.

### For experts

If you're an experienced DOS user and know your way around the inside of a personal computer, use the handy one-page *Quick Installation for the Above Board Plus 8 and Plus 8 I/O* that came with this manual. You may also want to manually install the Above Board software. Read Appendix F. It will tell you what you need to know.

If you're a software developer and you want to create programs that use expanded memory, call Customer Support and ask for a copy of the *Lotus/Intel/Microsoft Expanded Memory Specification*. This specification explains how programs can use expanded memory. Appendix B lists the Customer Support numbers.

### For everyone else

Read this manual for an explanation of the Above Board's features and installation procedures. Here's what you'll find in the remaining chapters:

- 
- 2** *Product Overview*  
Helps you determine the type of Above Board you have. Describes the three kinds of memory that can be supplied by the Above Board. Gives a summary of the boards' features and benefits. This summary also describes the accompanying software, and helps you identify which computers and which operating systems can work with the Above Board.
  - 3** *Installation Overview*  
An overview of the installation process. Read this to get a general idea of what you need to do to install the Above Board.
  - 4** *Adding memory to the Above Board*  
How to select memory chips and put them on your Above Board. If you're not adding memory, skip this chapter.
  - 5** *The Hardware Worksheet*  
Questions about the Above Board you need to answer. You'll need the information on the worksheet when you run the TESTAB program.
  - 6** *Inserting the Above™ Board in your computer*  
How to put the Above Board in your computer.
  - 7** *Running SETBOARD*  
How to run the interactive program that sets up the hardware on the Above Board. This chapter also gives you hardware setup information for IBM PCs, IBM XT's and compatible computers.

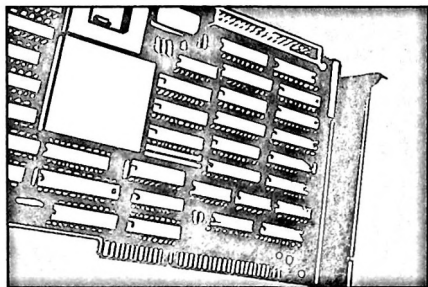
- 
- 8** *Running the IBM AT and compatible computer's setup program*  
How to run the computer's setup program for IBM AT and compatible computers. This also applies to 80386-based computers like the COMPAQ 386 that act like IBM AT and compatible computers. Skip this chapter if you don't plan to add conventional or extended memory.
- 9** *Running TESTAB*  
How to run the software that checks the memory chips on your Above Board.
- 10** *Running SOFTSET*  
How to start the program that installs the Above Board software onto a diskette or hard disk.
- 11** *Running CHKMEM*  
How to run the program that tells you how much of each type of memory is in your computer. CHKMEM also tells you how much expanded memory is being used and how much is available for application programs.
- 12** *RAM disks*  
What a RAM disk is and how to use Above Board RAM disks.
- 13** *The print buffer*  
What a print buffer is and how to use the Above Board print buffer.
- 14** *Parallel port*  
What a parallel port is and how to set one up.
- 15** *Serial port*  
What a serial port is and how to set one up.



---

The appendixes cover specialized technical topics. You don't need to read them unless one of the chapters advises you to. The Glossary at the end of the manual defines many of the technical terms used in the manual.

# Product Overview



## Chapter 2

2

---

## PRODUCT OVERVIEW

The Above Board lets you add memory above the 640K byte limit that DOS sets. By installing multiple Above Boards in your computer, you can add up to 32M bytes of expanded memory for DOS application programs, and up to 15M bytes of extended memory (IBM AT and compatible computers only) for XENIX, VDISK, and OS/2.

If you're familiar with the Above Board, and you're interested only in installation instructions, turn to Chapter 3.

This chapter is for readers who are unfamiliar with the Above Board. The information contained in this chapter:

- helps you determine which Above Board you have.
- describes the three kinds of memory your Above Board can supply.
- summarizes the features and benefits of the Above Board, and the accompanying software.

### Which Above™ Board do I have?

If your board has a flat metal retaining bracket you have the Above Board Plus 8.

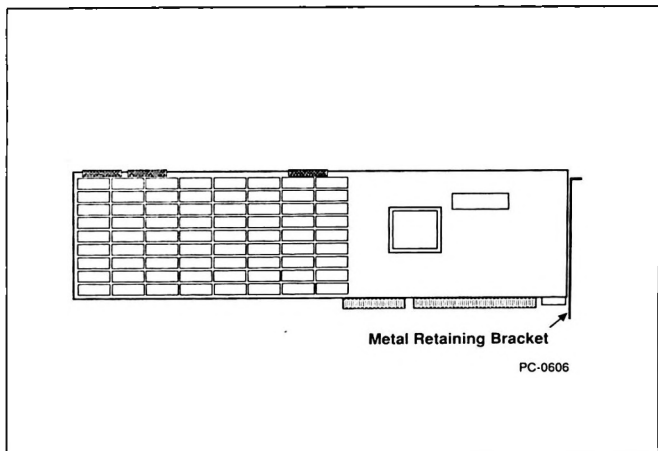
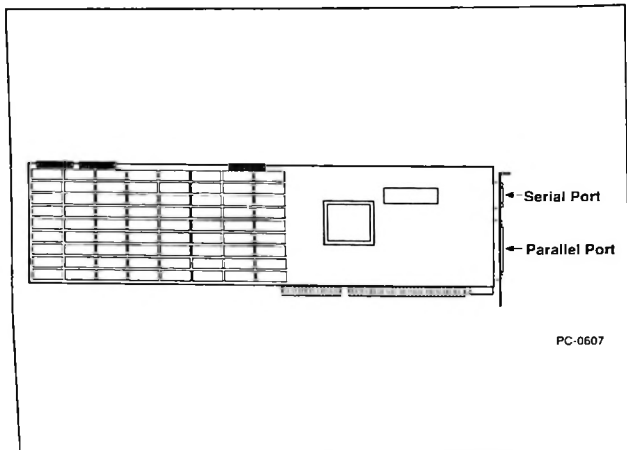


Figure 2-1 Above™ Board Plus 8

If your board has connectors protruding from the metal retaining bracket you have the Above Board Plus 8 I/O. This board has all the features of the Above Board Plus 8 with the addition of one serial port and one parallel port.



**Figure 2-2** *Above Board Plus 8 I/O*

The next section describes the three kinds of memory that can be supplied by the Above Board.

### **Three kinds of memory**

For maximum flexibility, you can define the Above Board memory to be conventional, expanded, extended, or any combination of the three. This section explains all three types and helps you decide which ones are right for you.

---

## **Conventional memory**

Conventional memory is memory that DOS manages. Application programs that run under DOS use conventional memory. DOS programs that you run from the compatibility box of OS/2 also operate in conventional memory.

Conventional memory is limited to 640K bytes. If your computer already has 640K of conventional memory, you can't add more. But if your computer has 256K or 512K, the Above Board lets you fill conventional memory to 640K bytes. Because almost all application programs can use the full 640K bytes, filling out your conventional memory should be your first priority.

### ***Mappable conventional memory***

The Above Board lets you use the conventional memory it supplies as mappable conventional memory. When you use programs that take advantage of mappable conventional memory, such as Windows 2.0 or DESQview, you can load more background applications (word processing, spreadsheets, etc.) and swap between the applications faster. For more information about mappable conventional memory, turn to Appendix E.

---

## Expanded memory

Expanded memory provides usable memory beyond DOS's 640K conventional memory limit. Expanded memory is divided into segments called pages. Your computer accesses these pages through a window of at least 64K bytes of memory. DOS application programs that conform to the *Lotus/Intel/Microsoft Expanded Memory Specification* (such as the latest versions of Lotus 1-2-3, Symphony, and Framework III) can use expanded memory. If you use DOS application programs, you'll probably want to add expanded memory (rather than extended) to your computer.

▼ **NOTE** *You can use expanded memory with DOS versions 3.0 and greater. You can't use expanded memory with XENIX or OS/2.*

## Extended memory

Extended memory is memory from 1M byte (1024K bytes) to 16M bytes (16,384K bytes).

The OS/2 and XENIX operating systems, VDISK RAM disk software, and specially written application programs (such as Framework III and AutoCAD) can use extended memory.

You can't use extended memory to run DOS application programs because extended memory is outside the range that DOS manages. For example, you can't store 1-2-3 spreadsheets in extended memory. If you use DOS application programs, you'll want to add expanded memory rather than extended memory.

IBM PC, XT, and compatible computers can't use extended memory -- they can only use conventional and expanded memory.

---

The next section describes the features and benefits of the Above Board.

## **A summary of Above Board™ Plus 8 and Plus 8 I/O features and benefits**

This section answers your two most important questions about the features and benefits of the Above Board:

- 1** "What do I get when I buy an Above Board Plus 8 or Plus 8 I/O?"
- 2** "What does the Above Board Plus 8 or Plus 8 I/O do for me?"

### **Hardware features**

**Feature --** The Above Board provides up to 8M bytes of memory on one board, and up to 14M bytes if you attach the optional 6MB Piggyback Option.

**Benefit --** You can add memory as your needs grow, without having to buy another memory board. You can configure this memory as conventional, expanded, or extended memory, or a combination of all three.



---

**Feature** -- The Above Board can supply conventional memory to 640K bytes. You have the option of making some or all of your conventional memory mappable.

**Benefit** -- You can fill out your conventional memory to 640K. If you use programs that take advantage of mappable conventional memory (such as Windows and DESQview), you can use this memory for multitasking with these programs. The Above Board gives you the memory to load more background applications, and switch between them faster.

**Feature** -- The Above Board fully supports the latest in expanded memory -- the *Lotus/Intel/Microsoft Expanded Memory Specification 4.0 (LIM EMS 4.0)*.

**Benefit** -- If you use memory-intensive DOS application programs (such as Lotus 1-2-3 Rev. 3.0, Microsoft Excel, and Microsoft Windows) that conform to *LIM EMS 4.0*, you can run bigger applications faster.

**Feature** -- The Above Board supplies extended (or OS/2) memory -- memory from 1M byte to 16M bytes.

**Benefit** -- The OS/2 and XENIX operating systems, VDISK RAM disk software, and specially written application programs (such as Framework III and AutoCAD) can use extended memory.

---

**Feature --** Extended memory for the Above Board can be set on 128K boundaries.

**Benefit --** The Above Board supports 128K boundaries for extended memory. If your computer has 1M or 2M bytes of memory, you can use the Above Board to supply extended memory where your system memory leaves off, without losing any of your computer's extended memory.

**Feature --** The Above Board Plus 8 I/O has a parallel and serial port. Read Chapter 14 and 15 for more information about parallel and serial ports.

**Benefit --** A parallel port is a connector to which you can attach an IBM-compatible parallel printer or other parallel device. A serial port lets you attach serial devices (such as a serial printer, modem, or mouse) to your computer. Setting up the serial and parallel ports is easy with SETBOARD, and using a serial and parallel port gives your computer greater flexibility.

**Feature --** The Above Board is compatible with IBM AT or compatible computers running up to 12.5 MHz, and with IBM PC, XT, or compatible computers that run at up to 8 MHz, and with Intel 80386™ based systems like the COMPAQ DESKPRO 386 that have AT bus slots.

**Benefit --** One board can meet your needs for multiple computers. As you grow and switch to faster computers, you don't need to leave your Above Board behind.

---

**Feature** -- The Above Board can supply conventional memory to 640K bytes. You have the option of making some or all of your conventional memory mappable.

**Benefit** -- You can fill out your conventional memory to 640K. If you use programs that take advantage of mappable conventional memory (such as Windows and DESQview), you can use this memory for multitasking with these programs. The Above Board gives you the memory to load more background applications, and switch between them faster.

**Feature** -- The Above Board fully supports the latest in expanded memory -- the *Lotus/Intel/Microsoft Expanded Memory Specification 4.0 (LIM EMS 4.0)*.

**Benefit** -- If you use memory-intensive DOS application programs (such as Lotus 1-2-3 Rev. 3.0, Microsoft Excel, and Microsoft Windows) that conform to *LIM EMS 4.0*, you can run bigger applications faster.

**Feature** -- The Above Board supplies extended (or OS/2) memory -- memory from 1M byte to 16M bytes.

**Benefit** -- The OS/2 and XENIX operating systems, VDISK RAM disk software, and specially written application programs (such as Framework III and AutoCAD) can use extended memory.

---

**Feature --** Extended memory for the Above Board can be set on 128K boundaries.

**Benefit --** The Above Board supports 128K boundaries for extended memory. If your computer has 1M or 2M bytes of memory, you can use the Above Board to supply extended memory where your system memory leaves off, without losing any of your computer's extended memory.

**Feature --** The Above Board Plus 8 I/O has a parallel and serial port. Read Chapter 14 and 15 for more information about parallel and serial ports.

**Benefit --** A parallel port is a connector to which you can attach an IBM-compatible parallel printer or other parallel device. A serial port lets you attach serial devices (such as a serial printer, modem, or mouse) to your computer. Setting up the serial and parallel ports is easy with SETBOARD, and using a serial and parallel port gives your computer greater flexibility.

**Feature --** The Above Board is compatible with IBM AT or compatible computers running up to 12.5 MHz, and with IBM PC, XT, or compatible computers that run at up to 8 MHz, and with Intel 80386<sup>TM</sup> based systems like the COMPAQ DESKPRO 386 that have AT bus slots.

**Benefit --** One board can meet your needs for multiple computers. As you grow and switch to faster computers, you don't need to leave your Above Board behind.

---

### **Software features**

**Feature --** The Above Board is compatible with DOS, OS/2, and the XENIX operating systems.

**Benefit --** One board can meet your needs as you grow. If you switch from DOS to OS/2, your Above Board can switch with you.

**Feature --** The SETBOARD program lets you choose how the computer uses the Above Board memory (conventional, extended, or a combination), and prepares the serial and parallel ports. Chapter 7 tells you more about SETBOARD.

**Benefit --** You can set up the hardware on your Above Board without setting any switches. This increases the speed and ease of Above Board installation.

**Feature --** The TESTAB program checks the RAM chips you installed and pinpoints any that are defective or improperly installed. Chapter 9 describes how to run TESTAB.

**Benefit --** With TESTAB you can be confident that your memory is working properly, and that your Above Board is reliable.

---

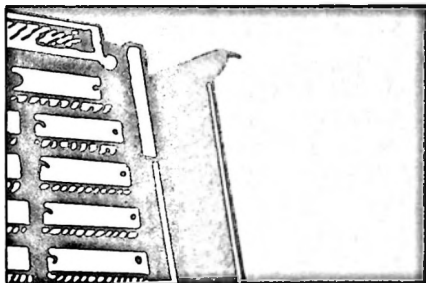
**Feature** -- The SOFTSET program copies the Above Board software onto a diskette or hard disk. It sets up expanded memory, lets you choose to make conventional memory mappable, sets up RAM disks, and a print buffer. Chapter 10 tells how to run SOFTSET.

**Benefit** -- The SOFTSET program is easy to use. It describes the choices you have, and offers guidelines to help you make those choices. The SOFTSET program is fast. It quickly installs your software so that you don't have to wait to use your Above Board.

**Feature** -- The CHKMEM program displays the amount of each type of memory in your computer (conventional, expanded, and extended). It also tells you how much expanded memory is being used, and how much is available for application programs. Chapter 11 tells you how to run CHKMEM.

**Benefit** -- CHKMEM lets you see and confirm the memory choices you made when you ran SETBOARD. It's an optional program that you can use to check how you set up your Above Board memory.

# Installation Overview



## Chapter 3

# 3

---

## INSTALLATION OVERVIEW

This chapter is an overview of the installation instructions for readers who aren't DOS experts. Experts can skip this chapter and refer to the one-page installation guide that accompanies this manual.

Installing the Above Board is an eight-part process for IBM AT and compatible computers, and for IBM PC, XT, and compatible computers:

- 1 Add memory to the Above Board.** You can put as much as 8M bytes (8192K bytes) on the board. If you need more memory, you can add up to 6M bytes (for a total of 14M bytes) by attaching the optional 6MB Piggyback Option. Chapter 4 discusses adding memory to the board.
- 2 Answer the Hardware Worksheet questions.** You'll need this information when you run the TESTAB program. Read Chapter 5 for instructions.
- 3 Insert the Above Board in the computer.** This chapter explains how to insert the board in an IBM AT, PC, XT, or compatible computer, and in an IBM PS/2 Model 30 and Model 30 286 computer. Read Chapter 6 for directions.
- 4 Run the SETBOARD program.** The SETBOARD program tells the Above Board how much memory is conventional or extended. It also controls the naming of any parallel and serial ports on your Above Board. Chapter 7 describes how to run the SETBOARD program.

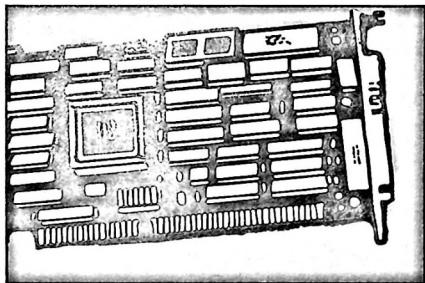


- 
- 5** **Set the system board switches** (*for IBM PC and compatible computers only*). If you used the Above Board to add conventional memory to an IBM PC or compatible computer, you may need to change the switches on the computer's system board after running SETBOARD. Chapter 7 describes how to set the switches.
  - 6** **Run the computer's setup program** (*for IBM AT and compatible computers, and compatible 80386-based computers only*). Most IBM AT and compatible computers and compatible 80386-based computers come with a setup program that recognizes new options you've added. You *must* run the computer's setup program if you used the Above Board to add conventional or extended memory. Chapter 8 gives explicit instructions on how to run the setup program for the IBM AT and COMPAQ 286 computers, and gives general instructions for compatible computers.
  - 7** **Run the TESTAB (confidence tests) program.** TESTAB pinpoints any non-functioning or improperly installed RAM chips on the Above Board. Although the confidence tests aren't required, Intel recommends that you run the tests if you have installed additional memory chips. Chapter 9 explains how to run these tests.
  - 8** **Run the SOFTSET program.** If you are adding expanded memory, RAM disks, a print buffer, or mappable conventional memory to your computer, run the SOFTSET program that comes with the Above Board. Chapter 10 explains how.

- 
- 9 Run the CHKMEM program.** The CHKMEM program lists the amount of conventional, expanded, and extended memory in your computer. Running this program is optional -- it provides you with a quick check to see if the memory is set up correctly. Read Chapter 11 for instructions on running CHKMEM.

After you perform all parts of the installation process, the Above Board will be ready to use. To get started, turn to the next chapter.

# Adding Memory to the Above™ Board



## Chapter 4

# 4

---

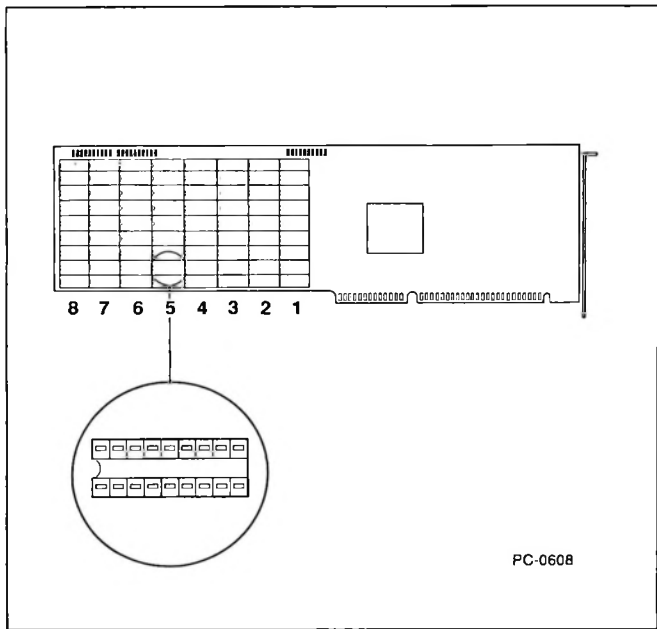
## **ADDING MEMORY TO THE ABOVE BOARD**

If your Above Board contains less than 8M bytes of memory, you can add more. This chapter explains how.

This chapter assumes the Above Board is out of your computer. If it's inside, follow the directions in your computer's *Installation and Setup Manual, Operations Guide*, or comparable manual to remove the cover of your system unit. Then take the Above Board out and place it, with the chips facing up, on a clean, dry, slightly padded static-free surface. Using a padded surface will help protect the components on the underside of the board.

### **Is your board already full?**

Before you buy memory chips, see whether your Above Board is already full. Figure 4-1 shows where the memory chips fit. The enlarged view shows an empty socket.



PC-0608

**Figure 4-1** *Location of memory chips on the Above Board Plus 8*

If any of the sockets in columns 1 to 8 on your Above Board are empty, you can add more memory. The rest of this chapter tells how.

---

If all the memory sockets are full, the board contains 8M bytes of memory. To add an additional 6M bytes of memory, you can purchase the optional 6MB Piggyback Option. A separate manual explains how to install the 6MB Piggyback Option.

▼ **CAUTION** *Intel makes several Above Board Piggyback Memory boards. Use only the 6MB Piggyback Option on the Above Board Plus 8 and Plus 8 I/O.*

## Selecting the memory chips

Follow these rules when selecting memory chips to add to your Above Board:

- Use only 1M-bit chips. The board will *not* work with 64K-bit or 256K-bit chips.
- The memory chips must operate at 120 nanoseconds or faster. For example, 100-nanosecond chips are fine. You can mix chips of different speeds. However, the performance of the Above Board is not improved by using faster chips.
- You must fill the columns in pairs. That means one set of 18 chips for two columns of sockets. So buy the chips in multiples of 18. Intel has verified that the chips listed in Table 4-1 work correctly in the Above Board. Other chips may work, but they haven't been verified.

**Table 4-1**      *Chips that work on the Above™ Board*

<b>Manufacturer</b>	<b>Chips</b>
Fujitsu	MB81C1000P-10 MB81C1000P-12
Hitachi	HM511000P-10S HM511000P-12S
Mitsubishi	M5M41000AP-10 M5M41000AP-12
Motorola	M5M511000P-10 M5M511000P-12
NEC	UPD421000C-10 UPD421000C-12
NMB	AAA1M100-10 AAA1M100-12
OKI	M511000RS-10 M511000RS-12
Samsung	KM41C1000P-10 KM41C1000P-12
Texas Instruments	TMS4C1024-10 TMS4C1024-12NL
Toshiba	TC511000P-10 TC511000P-12

### **Adding the memory chips**

- 1**    Decide how much memory you want to add to your Above Board. Each pair of empty columns can hold eighteen 1M-bit chips for a total of 2M bytes.

---

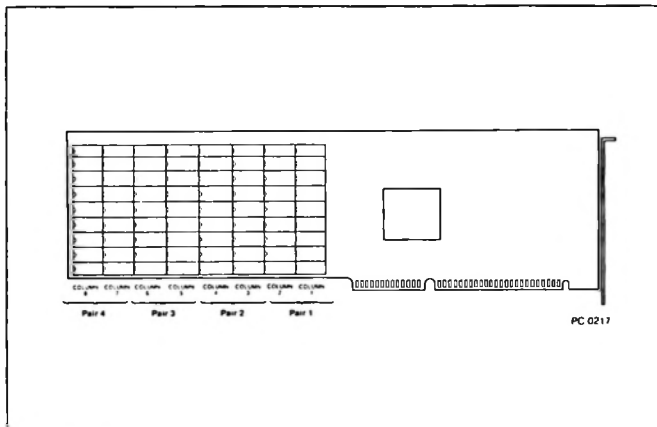
▼ **CAUTION** *Memory chips can be damaged by static discharge. You're less likely to discharge static electricity if you ground yourself by touching the metal back or side panel of your computer before you touch the chips. Moving around increases the possibility of static discharge, so limit your movements while installing the memory chips.*

- 2 Gather the materials you'll need -- your computer, manual, board, and chips -- and arrange them on a clean, dry, static-free work surface. Using a slightly padded surface will help protect the fragile components on the underside of the board.
- 3 Remove the static electricity from your hands by touching the metal back or side panel of your computer.

▼ **NOTE** *If you've never put a chip in a socket, read Appendix A for instructions.*

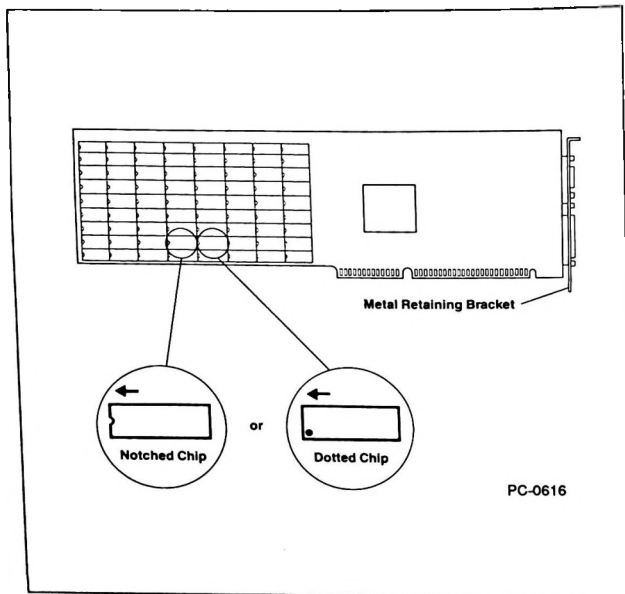
- 4 Insert the memory chips in the order shown in Figure 4-2. Fill Pair 1 before filling Pair 2, and so on. Each pair of columns must be entirely empty or entirely full (18 chips or none at all).





**Figure 4-2**     *Order for inserting memory chips*

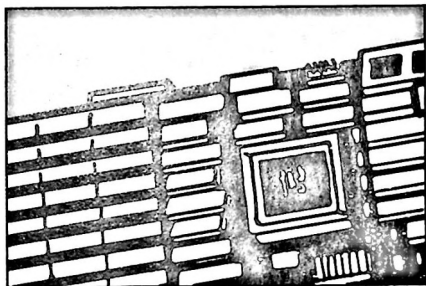
- 5 When the board and chips are oriented as in Figure 4-3, the notched or dotted edge of each memory chip should point away from the metal retaining bracket.



**Figure 4-3** *Orienting the chips correctly*

After you've added memory to the Above Board, turn to the next chapter and fill out the Hardware Worksheet.

# The Hardware Worksheet



## Chapter 5

5

---

## THE HARDWARE WORKSHEET

The Hardware Worksheet is a list of questions you need to answer so that all the important information about your Above Board is grouped together and easily accessible. By answering these questions, you'll be able to find this information whenever you need it (for example, when you run TESTAB in Chapter 9).

If the Above Board Plus 8 or Plus 8 I/O is your only Above Board, answer the questions in this chapter. If you have more than one Above Board, skip the rest of this chapter and turn to the Hardware Worksheet in Appendix C.

You can answer some of these questions before you install the Above Board. Fill in the rest of the information with the help of the summary screen at the end of SETBOARD.

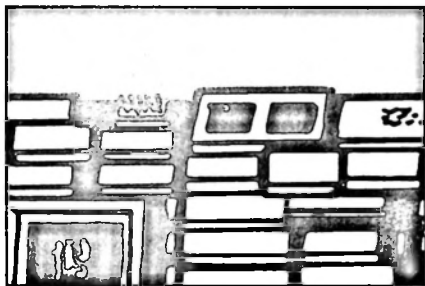
- How many of the Above Board's memory columns are filled? See Chapter 4 for instructions on adding memory to the Above Board.
- 
- If you have 6MB Piggyback Option attached to the Above Board, how many of the Piggyback Option's memory columns are filled?
- 
- If you choose to have your Above Board supply extended memory, what is the starting and ending extended memory address on the Above Board? You'll specify this information when you run SETBOARD, and need it only if you choose to have the Above Board supply extended memory.
-

- 
- If you have an Above Board Plus 8 I/O, what is the name of the parallel port (LPT1, LPT2, LPT3)? You can find this information when you run SETBOARD. See Chapter 14 for more information about the parallel port.
- 

- If you have an Above Board Plus 8 I/O, what is the name of the serial port (COM1, COM2)? You can find this information when you run SETBOARD. Chapter 15 describes the serial port.
- 

- At what bus speed does your computer run (6, 8, 10, or 12 MHz)?
-

# Inserting the Above™ Board In Your Computer



## Chapter 6

6

---

## INSERTING THE ABOVE™ BOARD IN YOUR COMPUTER

This chapter explains how to install the Above Board in your computer. It is divided into three main sections:

- Inserting the Above Board in an IBM AT or compatible computer.
- Inserting the Above Board in an IBM PC, XT, or compatible computer.
- Inserting the Above Board in IBM Personal System/2 Model 30 or Model 30 286. Throughout the other chapters in this manual, the instructions for the Personal System/2 Model 30 follow the guidelines for IBM PC, XT, and compatible computers, and the instructions for the Personal System/2 Model 30 286 follow the guidelines for IBM AT and compatible computers.

Turn to the section corresponding to your type of computer for installation instructions.

▼ **CAUTION** *Memory chips can be damaged by static discharge. You're less likely to discharge static electricity if you ground yourself by touching the metal back or side panel of your computer before you touch the Above Board. Moving around increases the possibility of static discharge, so limit your movements while installing the Above Board.*

### Inserting the Above™ Board in an IBM AT or compatible computer

This section describes how to insert an Above Board in an IBM AT or compatible computer. This also applies to 80386-based computers, like the COMPAQ 386, that are compatible with IBM ATs.

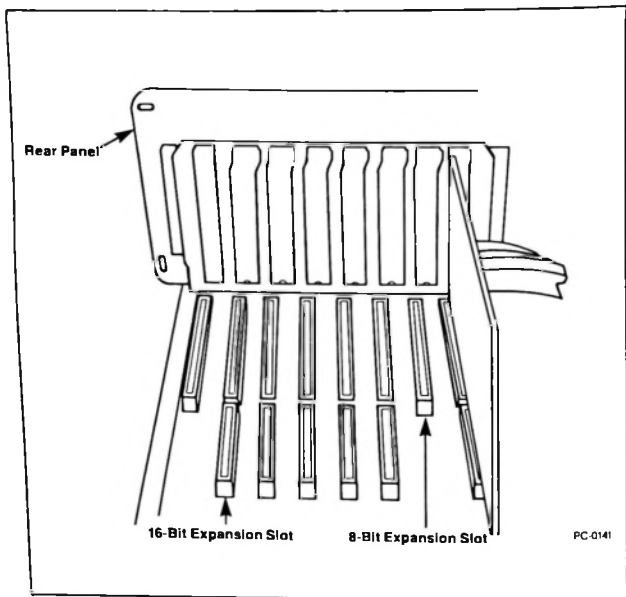
---

If you're inserting an Above Board in an IBM PC, XT, or compatible computer, follow the instructions in the next section of this chapter. If you have an IBM Personal System/2 Model 30 or Model 30 286, follow the instructions in the third section of this chapter.

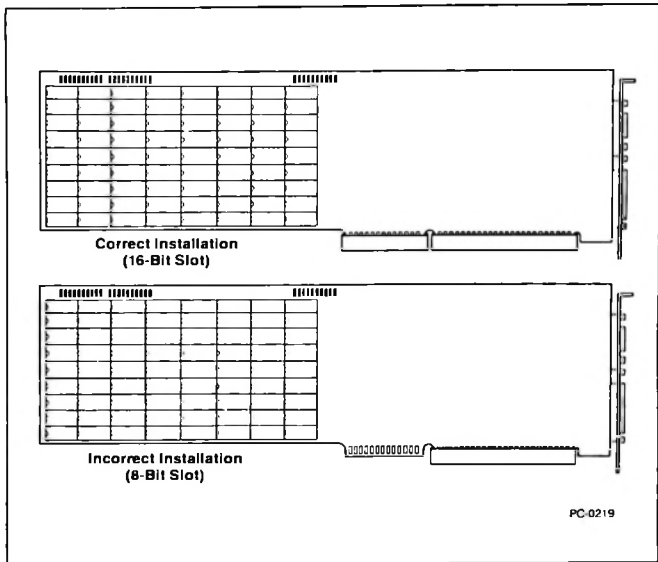
- 1** Unplug the computer from the outlet, disconnect the cables, and remove the cover. If you don't know how to remove the cover, refer to your computer's *Installation and Setup Manual*, *Operations Guide*, or equivalent manual.
- 2** Locate an empty 16-bit expansion slot in the computer. A 16-bit slot has two connectors on the system board where the gold fingers at the bottom of the Above Board fit. An 8-bit slot has only one connector.

Figure 6-1 shows the difference between a 16-bit and an 8-bit expansion slot. Figure 6-2 shows an Above Board inserted in 16-bit (correct) and 8-bit (incorrect) expansion slots.



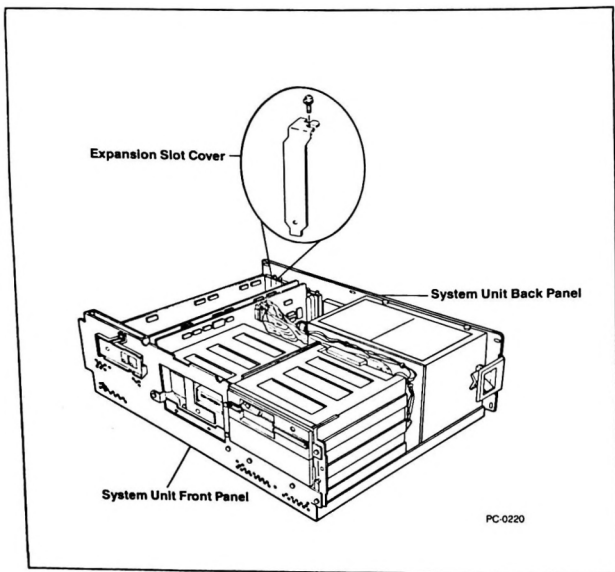


**Figure 6-1** *A 16-bit and an 8-bit expansion slot in an IBM AT or compatible computer*



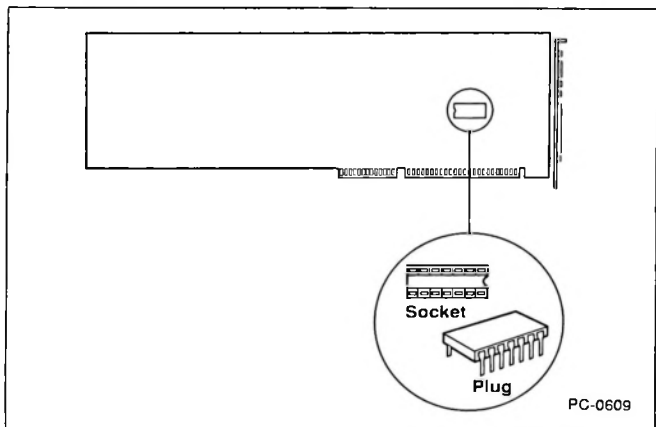
**Figure 6-2** *An Above™ Board installed in a 16-bit slot of an IBM AT or compatible computer*

- 3 Use a screwdriver to remove the screw holding the cover of one of the unused 16-bit expansion slots. Save the screw to use later. Remove the expansion slot cover. Figure 6-3 shows the location of the screw and the expansion slot cover.



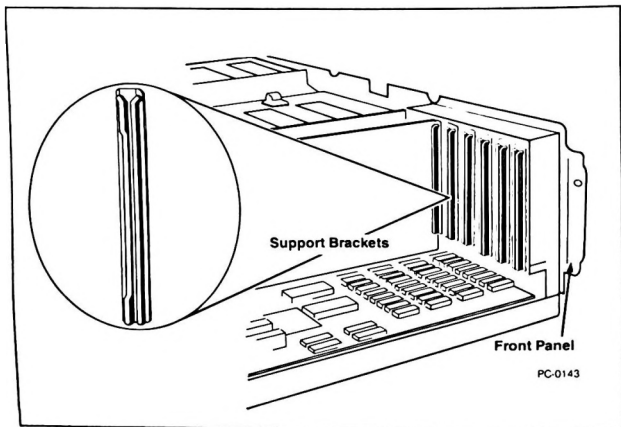
**Figure 6-3** *Location of the expansion slot cover on an IBM AT or compatible computer*

- ▼ **NOTE** *Be sure the socket shown in Figure 6-4 is empty. This socket is for the PC selection plug, which should be inserted for IBM PS/2 Model 30s, IBM PC, XT, and compatible computers only. The PC selection plug is not installed at the factory, so the socket should be empty. If the socket isn't empty, remove the plug. Do not remove the socket.*



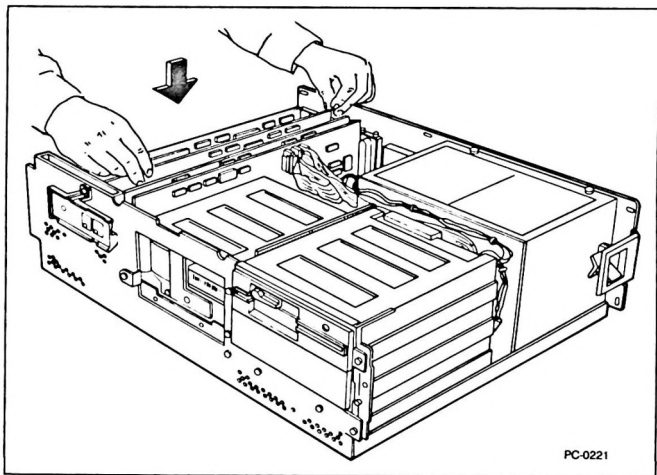
**Figure 6-4** *Location of the PC selection plug socket on the Above™ Board*

- 4 Line up the edge of the Above Board so that it fits into the top of the support bracket (inside the front panel of your computer) that corresponds to the empty 16-bit expansion slot whose cover you removed in step 3. The support bracket is shown in Figure 6-5.



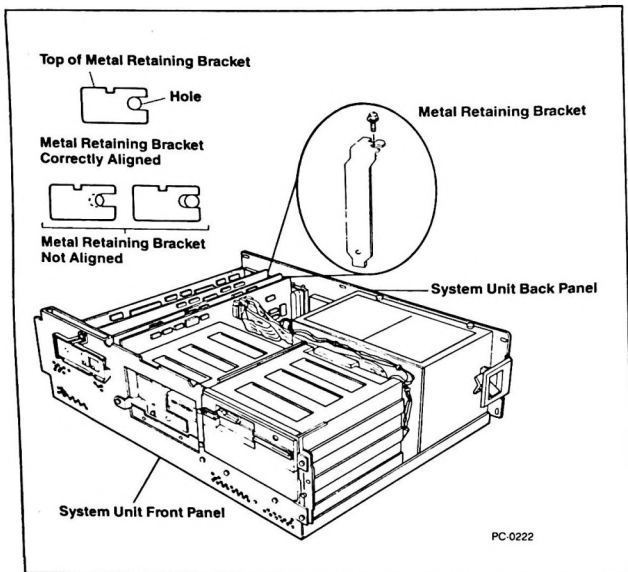
**Figure 6-5**     *The support bracket for an IBM AT or compatible computer*

- 5 Hold the board at each corner of the top and push down as shown in Figure 6-6. The board should slide easily most of the way into the unused expansion slot. When you feel some resistance, check the alignment. Then push down firmly to seat the board in the expansion slot connector.



**Figure 6-6** *Inserting the Above™ Board in an IBM AT or compatible computer expansion slot*

- 6 Align the opening in the top of the Above Board's metal retaining bracket with the hole in the top edge of the system unit's rear panel as shown in Figure 6-7. Fasten the metal retaining bracket to the panel with the screw you removed in step 3.



**Figure 6-7** *Aligning and fastening the metal retaining bracket to the back panel of an IBM AT or compatible computer*

---

▼ NOTE *Some IBM AT or compatible computers contain a jumper or switch that tells the computer whether the system board contains 256K or 512K bytes of memory. Refer to your computer's Installation and Setup Manual, Operations Guide, or comparable manual to find out if your computer has this jumper or switch, and where it is located. If you don't want the Above Board to supply mappable conventional memory, be sure that this jumper or switch is set for the amount of memory on your computer's system board.*

▼ NOTE *Only conventional memory supplied by the Above Board can be set up as mappable conventional memory. If you are using a multitasking application like Microsoft Windows or Quarterdesk's DESQview, and want conventional memory defined as mappable, you may need to disable some of the conventional memory on your computer. Refer to your computer's Installation Manual, Operations Guide, or similar manual for instructions. For more information on how mappable conventional memory is provided and used, see Appendix E.*

- 7 Replace the cover of your computer, reconnect the cables, and plug the power cord into the outlet. If you don't know how to replace the cover, refer to your computer's *Installation and Setup Manual, Operations Guide*, or comparable manual.

Now that you've installed the Above Board in your IBM AT or compatible computer, turn to the next chapter and run the SETBOARD program.

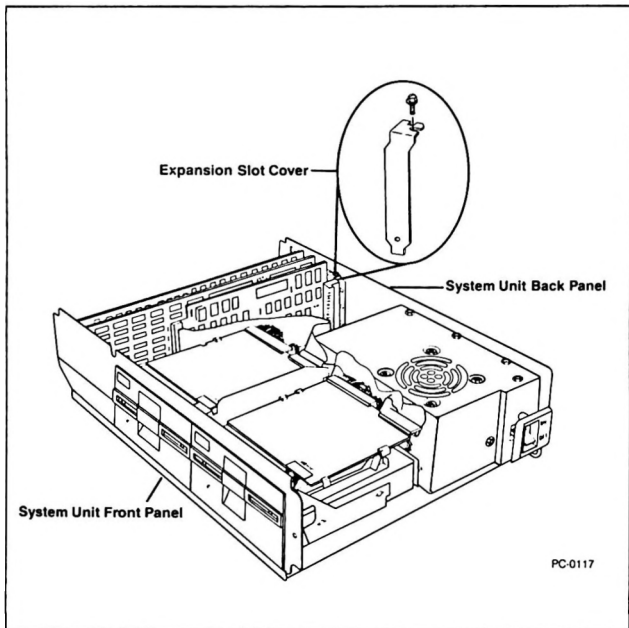


---

## Inserting an Above™ Board in an IBM PC, XT, or compatible computer

This section describes how to insert an Above Board in an IBM PC, XT, or compatible computer. If you're installing an Above Board in an IBM AT or compatible computer, follow the instructions in the first section of this chapter. If you're installing the Above Board in an IBM Personal System/2 Model 30 or Model 30 286, follow the instructions in the last section of this chapter.

- 1** Unplug your computer from the outlet, disconnect the cables, and remove the cover. If you don't know how to remove the cover, refer to your computer's *Guide to Operations*, or comparable manual.
- 2** Use a screwdriver to remove the screw holding the cover of one of the unused expansion slots. Save the screw to use later. Remove the expansion slot cover. Figure 6-8 shows the location of the screw and the expansion slot cover.



**Figure 6-8** *Location of the expansion slot cover on an IBM PC, XT, or compatible computer*

- 3 Find the plastic packet containing the PC selection plug and the support bracket supplied with your Above Board. Figure 6-9 shows the plug and the bracket.

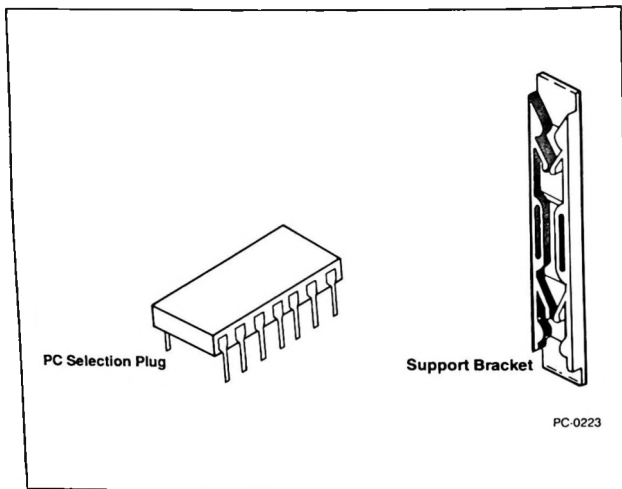
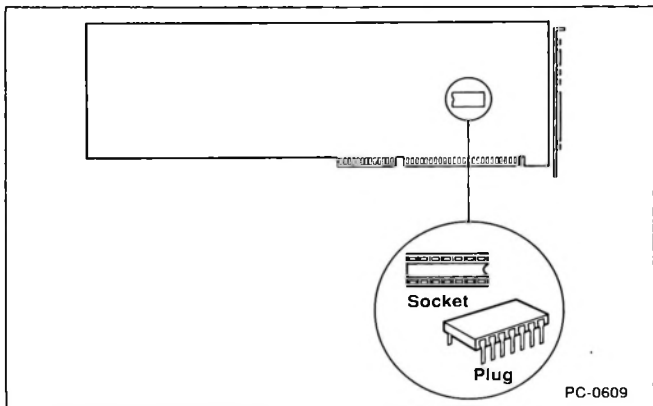


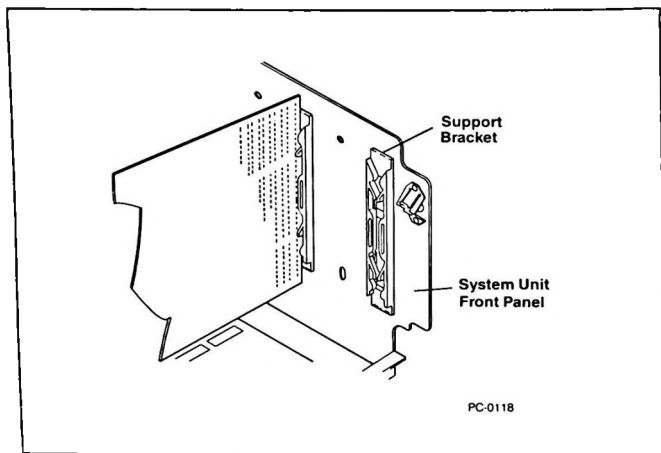
Figure 6-9 The PC selection plug and the support bracket

- 4 Insert the PC selection plug in the socket (shown in Figure 6-10) on the Above Board. This plug allows you to use the Above Board in an IBM PC, XT, or compatible computer.



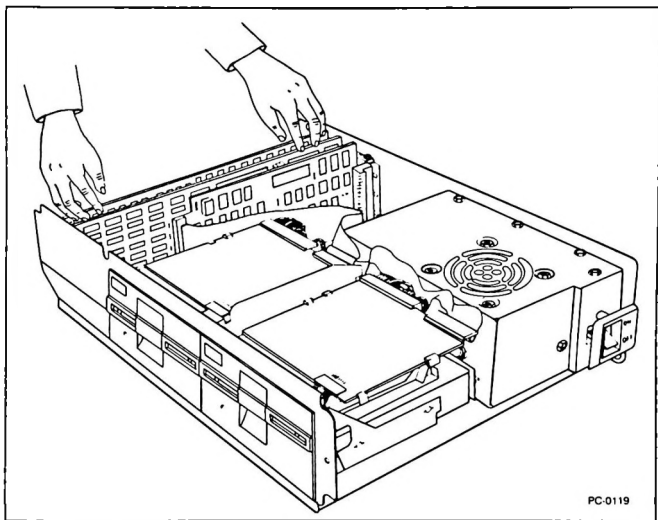
**Figure 6-10** *Location of the PC selection plug socket on the Above™ Board*

- 5 Insert the support bracket in the holes inside the front panel of your system unit. The support bracket should line up with the cutout you exposed (in the back panel) when you removed the expansion slot cover. Figure 6-11 shows the support bracket correctly inserted.



**Figure 6-11** *The support bracket for an IBM PC, XT, or compatible computer*

- 6** Line up the Above Board so that one edge fits into the top of the support bracket inside the front panel of your computer and the metal retaining bracket fits into the exposed cutout. Hold the board at each corner of the top and push down as shown in Figure 6-12.

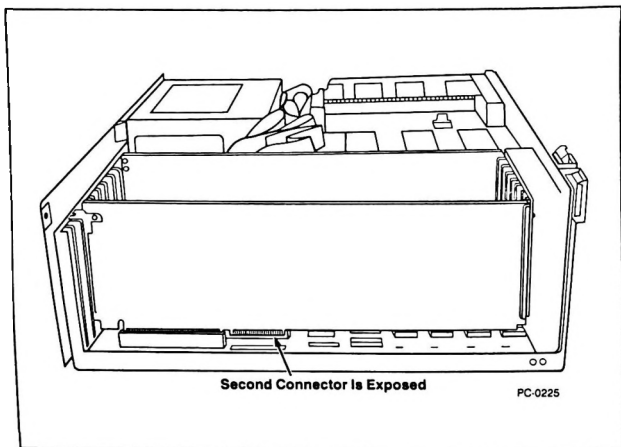


PC-0119

**Figure 6-12** *Inserting the Above™ Board in an IBM PC, XT, or compatible computer expansion slot*

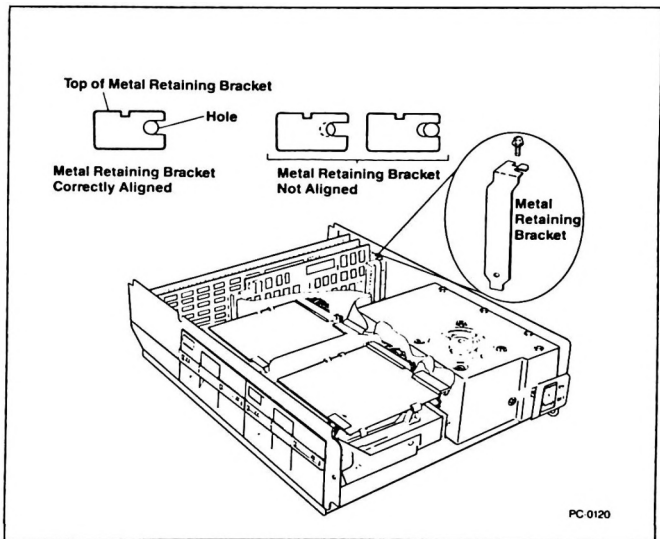
- 7** The board should slide easily most of the way into the unused expansion slot. When you feel some resistance, check the alignment. Then push down firmly to seat the board in the expansion slot connector. Figure 6-13 shows the Above Board correctly seated in an expansion slot.

▼ **NOTE** *When the Above Board is correctly seated in the expansion slot, the board's second connector is exposed as shown in Figure 6-13.*



**Figure 6-13** *Above™ Board correctly seated in an IBM PC, XT, or compatible computer expansion slot*

- 8 Align the opening in the top of the Above Board's metal retaining bracket with the hole in the top edge of the rear panel of the computer as shown in Figure 6-14. Fasten the metal retaining bracket to the panel with the screw you removed in step 2.



**Figure 6-14** *Aligning and fastening the metal retaining bracket to the panel of an IBM PC, XT, or compatible computer*



---

▼ **NOTE** *Only conventional memory supplied by the Above Board can be set up as mappable conventional memory. If you are using a multitasking application like Microsoft Windows or Quarterdesk's DESQview and want conventional memory defined as mappable, you may need to disable some of the conventional memory on your computer. Refer to your computer's Guide to Operations or similar manual for instructions. For more information on how mappable conventional memory is provided and used, see Appendix E.*

- 9 Replace the cover of your computer, reconnect the cables, and plug the power cord into the outlet. If you don't know how to replace the cover, refer to your computer's *Guide to Operations*, or comparable manual.

Now that you've inserted the Above Board in your computer, turn to the next chapter and run the SETBOARD program.

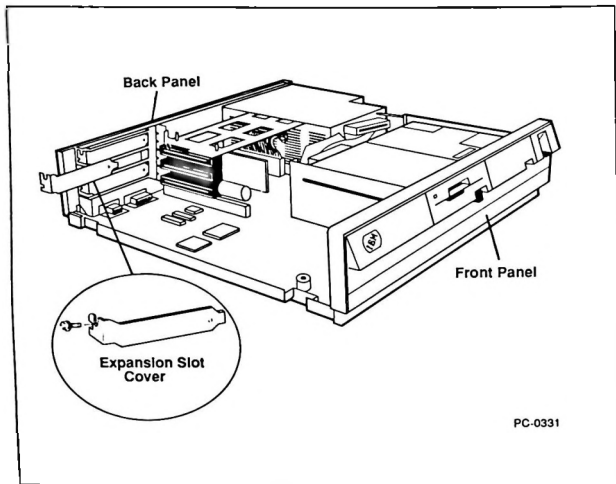
## **Inserting the Above™ Board in an IBM Personal System/2 Model 30 or Model 30 286 computer**

This section describes how to insert an Above Board in an IBM Personal System/2 Model 30 computer. If you're installing the Above Board in an IBM Personal System/2 Model 30 286, follow the instructions for the Model 30. The instructions are similar. Any differences are stressed in the individual installation steps.

If you're installing the Above Board in an IBM PC, XT, or compatible computer, follow the instructions in the previous section. If you're installing the Above Board in an IBM AT or compatible computer, follow the instructions in the first section of this chapter.

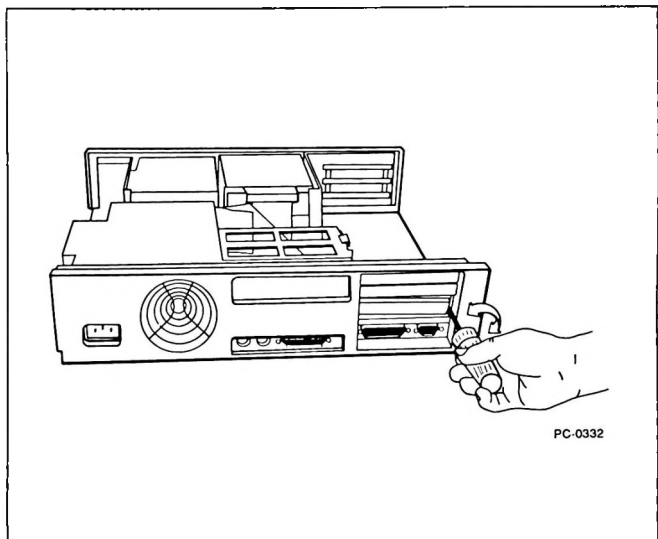
- 
- 1 Unplug your computer from the outlet, disconnect the cables, and remove the cover. If you don't know how to remove the cover, refer to the *IBM Personal System/2 Model 30 Guide to Operations* (or *Model 30 286 Guide to Operations*).
  - 2 Use a screwdriver to remove the screw holding the cover of the top or middle unused expansion slots. Save the screw to use later. Remove the expansion slot cover. Figure 6-15 shows the location of the screw and an expansion slot cover.

▼ **CAUTION** *Don't install the Above Board in the bottom expansion slot. It may come in contact with the system battery and cause a short circuit.*



**Figure 6-15** *Location of an expansion slot cover*

- 3** The expansion slots are covered by plastic inserts on the outside back panel of the system unit. Use a flat-blade screwdriver to remove the plastic insert that corresponds to the expansion slot cover you removed in step 2. Figure 6-16 shows how to remove the insert.



**Figure 6-16**    *Removing the plastic insert*

- 4** Find the plastic packet containing the PC selection plug and the support bracket supplied with your Above Board. Figure 6-17 shows the plug and the bracket.

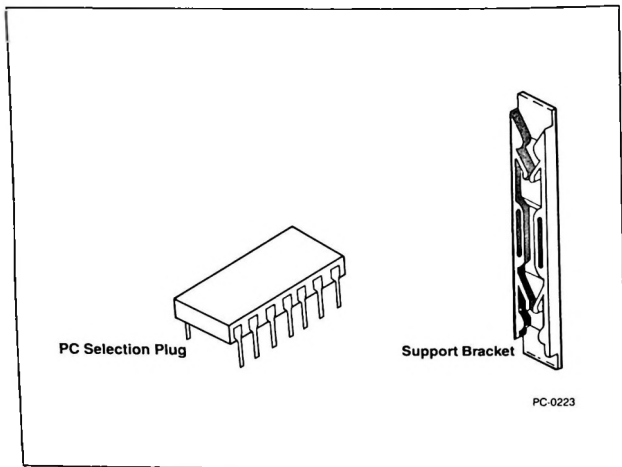


Figure 6-17 *The PC selection plug and support bracket*

- 5 If you're installing the Above Board in a Model 30 286, discard the PC selection plug. It's necessary only in a Model 30 and IBM PC, XT, and compatible computers. Skip step 6 and go to step 7.

If you're inserting the Above Board in a Model 30, you must insert the PC selection plug in the socket. Go on to step 6.

- 6 Lay the Above Board on a clean, dry surface and insert the PC selection plug in the socket shown in Figure 6-18.

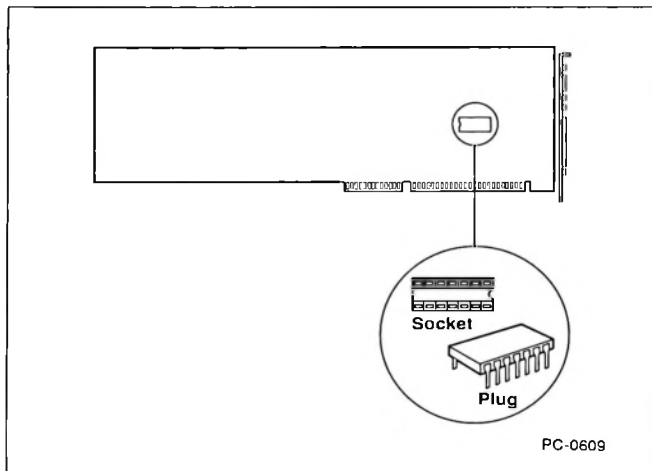


Figure 6-18 Location of the PC selection socket on the Above™ Board

- 7 Discard the support bracket supplied with the Above Board. You don't need it for an IBM Personal System/2 Model 30 or Model 30 286 computer.
- 8 Line up the Above Board so the metal retaining bracket fits into the exposed cutout and the edge opposite the metal retaining bracket fits into the support bracket inside the front panel of the computer. Hold the board at each corner of the top and push firmly as shown in Figure 6-19.

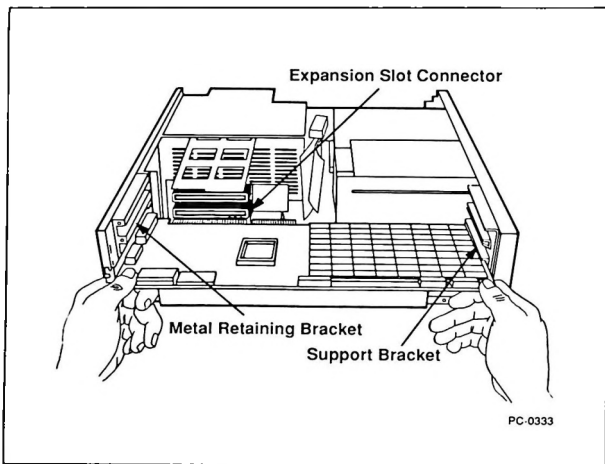


Figure 6-19 *Inserting the Above™ Board in a Model 30 expansion slot*

- 9 The board should slide easily most of the way into the unused expansion slot. When you feel some resistance, check the alignment. When aligned, push firmly to seat the board in the expansion slot connector. Figure 6-20 shows the Above Board correctly seated in an expansion slot.

▼ **NOTE** *When the Above Board is correctly seated in the Model 30 expansion slot, the board's second connector is exposed as shown in Figure 6-20. The second connector is not exposed in a Model 30 286.*

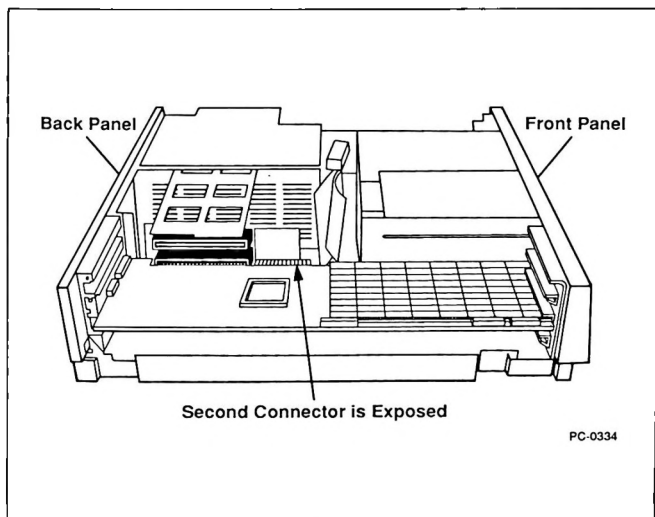


Figure 6-20 *Above™ Board correctly seated in an IBM Personal System/2 Model 30*



- 10 Align the opening in the top of the Above Board's metal retaining bracket with the hole in the top edge of the back panel of the system unit as shown in Figure 6-21. Fasten the metal retaining bracket to the panel with the screw you removed in step 2.

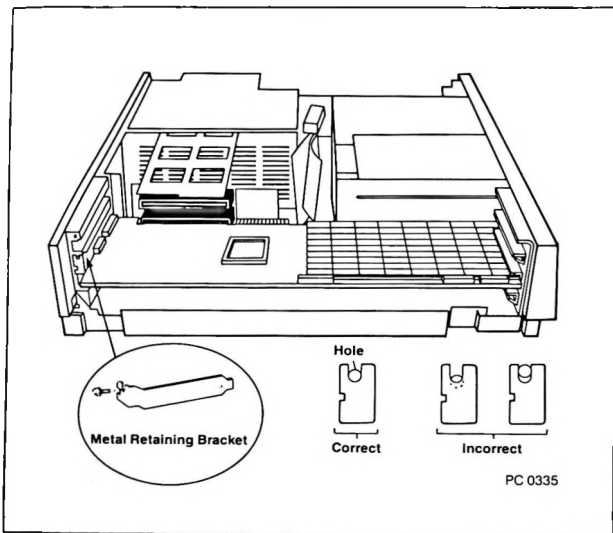


Figure 6-21 *Aligning and fastening the metal retaining bracket to the panel of a Model 30*

---

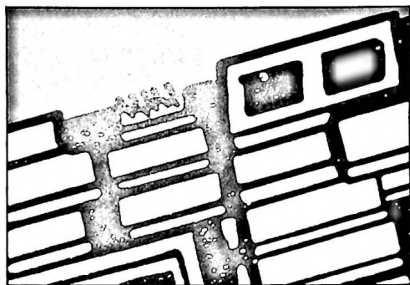
▼ **NOTE** *Only conventional memory supplied by the Above Board can be set up as mappable conventional memory. If you are using a multitasking application like Microsoft Windows or Quarterdesk's DESQview and want conventional memory defined as mappable, you may need to disable some of the conventional memory on your computer. See your computer's Installation Manual, Operations Guide, or similar manual for instructions. For more information on how mappable conventional memory is used and provided, see Appendix E.*

- 11** Replace the cover of your system unit, reconnect the cables, and plug the power cord into the outlet. If you don't know how to replace the cover, refer to *IBM Personal System/2 Model 30 Guide to Operations*.

Now that you've inserted the Above Board in your computer, turn to Chapter 7 and run the SETBOARD program.

▼ **NOTE** *If you need the software on a 3.5-inch diskette, call Customer Support or fill out and mail the postcard that came with your Above Board. Intel will send you the Above Board software on a 3.5-inch diskette.*

# Running SETBOARD



## Chapter 7

7

---

## RUNNING THE SETBOARD PROGRAM

SETBOARD is an interactive program that sets up the hardware on the Above Board. You must run SETBOARD immediately after putting the board in your computer, and you must run it again whenever you want to change the way your Above Board is set up.

- ▼ **NOTE** *SETBOARD runs only under DOS. If you normally use XENIX or OS/2, temporarily switch to DOS to run SETBOARD.*

### What SETBOARD does

SETBOARD prepares the Above Board's hardware to work in your computer. This program serves the same purpose as the hardware switches on other add-in boards -- but with SETBOARD, you can change the way your Above Board is set up without taking your computer apart.

SETBOARD performs these functions:

- Sets up memory -- SETBOARD lets you choose how the computer uses the Above Board memory (as conventional, extended, or a combination). You can rerun SETBOARD any time you need to change the way the memory is set up.
- ▼ **NOTE** *The Above Board lets you set up extended memory in 128K blocks. If your computer has 1M or 2M bytes of memory, you can use the Above Board to supply extended memory where your system memory leaves off, without losing any of your computer's extended memory.*
- Prepares serial and parallel ports -- if you have an Above Board Plus 8 I/O, SETBOARD prepares the serial and parallel ports the way you want.

- 
- Sets up technical options -- SETBOARD lets you set up technical options for the Above Board, such as the board's base I/O address and setup necessary to accommodate the bus speed of your computer.

## Before you use SETBOARD

Before you use SETBOARD, you should back up the Above Board software. Make a backup copy of the Intel diskette on a *diskette* -- don't back up the Intel software on your hard disk. Then use the backup diskette to run SETBOARD and the other Above Board programs.

Refer to the DOS manual that came with your computer if you don't know how to copy a diskette.

## Using SETBOARD

This section describes how to start SETBOARD, explains the different paths through the program, explains how to complete the Hardware Worksheet, and lists some special notes about using the program.

- ▼ **NOTE** *If you are installing more than one Above Board Plus 8, Plus 8 IIO, Plus, Plus IIO, 286, or PS/286 in the same computer, you must insert them in your computer one at a time and run SETBOARD after each insertion. For more information about using multiple Above Boards in the same computer, refer to Appendix C.*

---

## Starting SETBOARD

To start SETBOARD, turn on or restart your computer using a plain DOS diskette. A plain DOS diskette contains no application programs and doesn't include an AUTOEXEC.BAT file. Then insert the backup copy of your Intel diskette in drive A and, at the DOS prompt, type

```
A: SETBOARD
```

and press ENTER. Now just follow the instructions that SETBOARD gives you.

## The different paths through SETBOARD

After you start SETBOARD, it asks you a few questions about your computer, and then gives you a choice of two methods to set up your Above Board. These methods are automatic setup and manual setup. Here's a description of each one:

- **Automatic setup** prepares your board for you. This is the easiest and fastest way to set up your board. You don't have to make any decisions about how the memory or ports (if your board has them) are set up.

▼ **NOTE** *If your computer runs at 10 MHz or faster, or if you want to allocate some Above Board memory as extended memory, you must run manual setup to prepare the Above Board.*

If you choose automatic, SETBOARD sets up your board as follows:

- If your computer doesn't already have 640K bytes of conventional memory, SETBOARD uses Above Board memory to fill conventional memory to 640K bytes.

- 
- Any memory you don't allocate as conventional or extended memory is available to be used as expanded memory. Expanded memory is set up when you run SOFTSET (Chapter 10).
  - If the board is an Above Board Plus 8 I/O, SETBOARD assigns the next available I/O addresses to the parallel and serial ports.

▼ **NOTE** *Running automatic setup after manual setup may change some of the choices you have made. Make sure you verify the setup before you let SETBOARD prepare your board. If you've previously set up the board to supply extended memory with the SETBOARD software, running SETBOARD's automatic setup again won't change the extended memory setup.*

- **Manual setup** lets you manually prepare the memory and ports (if present) on the Above Board. You can select from all of the options for setting up memory and ports.

You can also run manual setup in conjunction with automatic setup. For example, if you run automatic setup, but find you need to change one option on the board, run manual setup to change that option.

Manual setup also lets you choose several technical options:

- the Above Board's base I/O address
- uncommonly used serial ports
- serial port interrupt assignments
- extended memory starting and ending addresses

- 
- bus speed

Select the default settings recommended by SETBOARD unless your computer has very specialized needs. If you've already run SETBOARD, the values displayed reflect the current settings.

You can also view the contents of the Above Board's Electrically Erasable Programmable Read Only Memory (EEPROM). Viewing the EEPROM is useful only for helping a Customer Support representative troubleshoot your board if it's not working properly. Refer to Appendix B for information on how to contact Customer Support.

### **Completing the Information on the Hardware Worksheet**

Before you installed your Above Board, you answered some of the Hardware Worksheet questions in Chapter 5 or Appendix C of this manual. Now you can complete the worksheet with the help of the SETBOARD program.

After setting up the Above Board, follow these guidelines to complete the worksheet.

- If the Above Board Plus 8 or Plus 8 I/O is your only Above Board, use the summary screen at the end of SETBOARD to help you answer the remaining questions in Chapter 5.
- If you have multiple Above Boards, use the "view" option in SETBOARD to fill out the rest of the worksheet in Appendix C.



---

## Special notes about SETBOARD

This section lists some special notes about using SETBOARD.

- 1** For IBM AT and compatible computers: If you use SETBOARD to add conventional or extended memory, you may receive a memory size error after SETBOARD restarts your computer. This is normal -- you'll correct the error when you run the computer's setup program (described in Chapter 8 of this manual).

For IBM PC and compatible computers: If you set up the Above Board to supply conventional memory, you will receive a memory size error after SETBOARD restarts your computer. You'll correct this error by changing the switch settings on your computer's system board. The last section of this chapter tells you how.

- 2** If you must move an Above Board Plus 8 or Plus 8 I/O from one computer to another, follow these directions carefully:
  - *Before* moving the board to another computer, run SETBOARD again with manual setup to set up the board so that it doesn't supply any conventional or extended memory or ports. Setting up the board like this before you move it ensures you won't have conflicts when you put the board in the other computer.
  - After the board is in the new computer, run SETBOARD again to prepare the board to fit your needs.

---

## After running SETBOARD

If you have an IBM AT or compatible computer and you added conventional or extended memory, skip the rest of this chapter and go to Chapter 8 for instructions on running your computer's setup program. If you didn't add conventional or extended memory, skip the rest of this chapter and turn to Chapter 9 to learn how to test the memory on your Above Board.

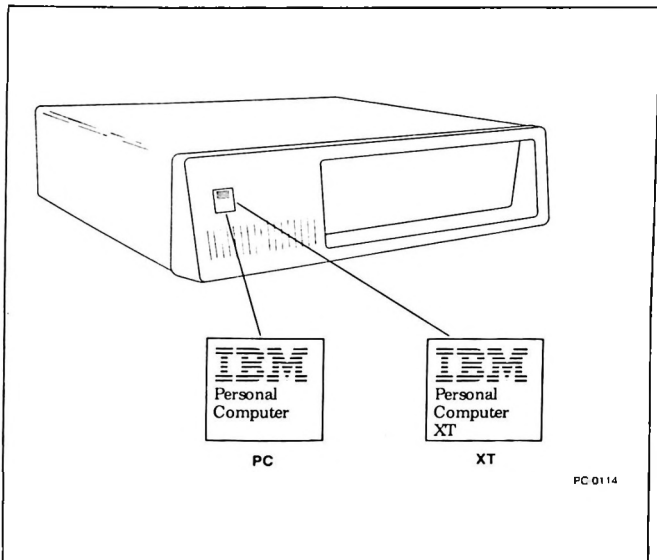
If you have an IBM PC or compatible computer, and you added conventional memory, read the next section.

## For IBM PC or compatible computers

If you have an IBM PC or compatible computer, and you used the Above Board to add conventional memory, you may need to change the switches on your computer's system board after running SETBOARD. If you didn't add conventional memory, skip the rest of this chapter and chapter 8, and go to Chapter 9.

These steps explain how to set the system board switches.

- 1 Identify your computer. IBM XT computers have a nameplate that reads "IBM Personal Computer XT" in the upper left corner of the front of the system unit. IBM PC computers have a similar nameplate that reads "IBM Personal Computer." Figure 7-1 shows the difference.

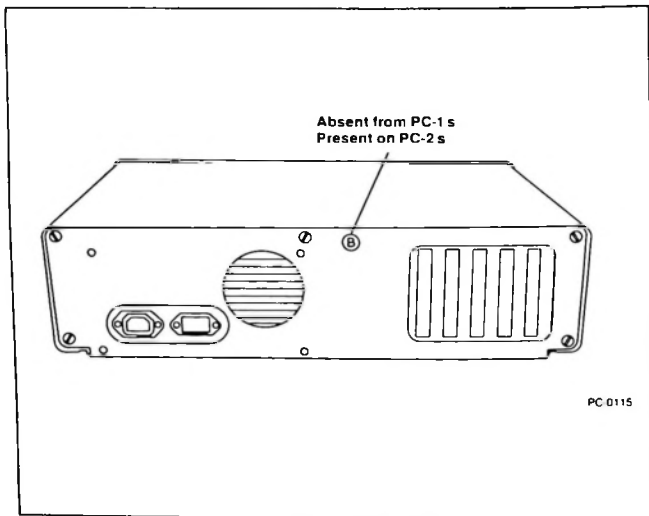


**Figure 7-1** *Distinguishing between IBM PC and IBM XT computers*

If your computer is an XT, you don't need to change any switches on the system board. Skip the rest of this chapter and go to Chapter 9.

- 2** If your computer is a PC, you must know if it's a PC-1 or a PC-2. PC-2s have the letter "B" stamped on the back panel of the system unit, whereas PC-1s don't. Figure 7-2 shows where to find the "B."

- ▼ **NOTE** *Some technically advanced PC-1 users have updated their computers (replaced the ROM BIOS). These updated PC-1s behave as if they're PC-2s. If your PC-1 has been updated, follow the instructions for a PC-2.*



**Figure 7-2** *Distinguishing between PC 1s and PC 2s*

- 3** Unplug your computer from the outlet, disconnect the cables, and remove the cover. If you don't know how to remove the cover, refer to your computer's *Guide to Operations*, or comparable manual.

- 4 Find your PC's system board. It's the large board at the bottom of the computer unit. Now, find the switch block labeled SW2. Figure 7-3 shows its location.

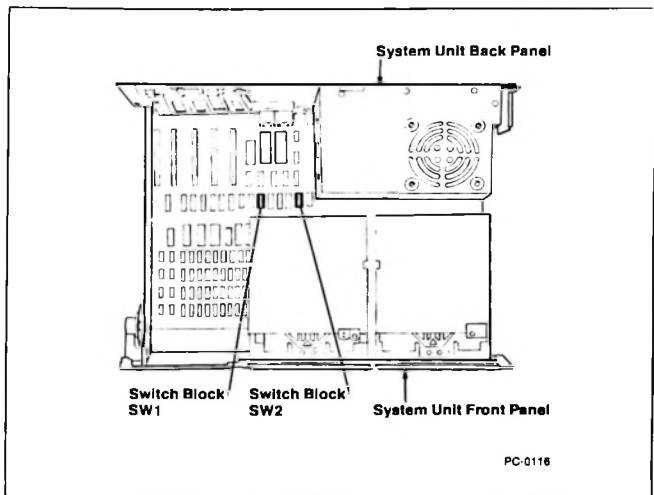





Figure 7-3 Location of switch block SW2 in an IBM PC

▼ **NOTE** IBM uses two kinds of switch blocks. Some have slide switches and some have rocker switches. To set slide switches, use a ball-point pen to push the switch to the ON or OFF side of the switch block. To set rocker switches, use the pen to press down on the ON or OFF side of the switch. Don't use a pencil to set the switches -- the graphite in the lead could short-circuit the switch.

- 5 If you have a PC-1, set the system board switches on SW2 as shown in Table 7-1. If you have a PC-2 set the system board switches as shown in Table 7-2.




Table 7-1 PC-1 system board switch settings for conventional memory

Conventional memory provided by the Above Board	PC-1 switch settings (switches 1 through 4 on SW2)
128K bytes* (512 through 640K)	
256K bytes (256K through 512K)	
384K bytes* (256 through 640K)	
None	No change

\*PC-1s can use only 544K bytes of conventional memory. However, the Above Board can use the additional 96K (which would normally appear between 544K and 640K) as expanded memory.

▼ NOTE Do not change any other switches in your computer.

**Table 7-2 PC-2\* system board switch settings for conventional memory**

Conventional memory provided by the Above Board	PC-2 switch settings (switches 1 through 5 on SW2)
128K bytes (512 through 640K)	
256K bytes (256K through 512K)	
384K bytes (256K through 640K)	
None	No change

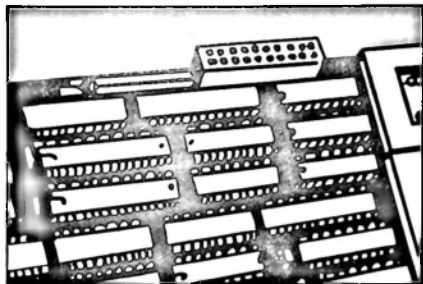
\*Or PC-1s with an updated ROM BIOS.

▼ **NOTE** *Do not change any other switches in your computer.*

- 6 Replace the cover of your computer, reconnect the cables, and plug the power cord into the outlet. If you don't know how to replace the cover, refer to your computer's *Guide to Operations*, or comparable manual.

Now that you've set your computer's system board switches, skip Chapter 8 and go to Chapter 9.

# Running The IBM AT and Compatible Computer's Setup Program



Chapter 8

8

*Running The IBM AT and  
Compatible Computer's Setup Program 8-1*



---

## **RUNNING THE IBM AT OR COMPATIBLE COMPUTER'S SETUP PROGRAM**

If you use the Above Board to add conventional or extended memory to an IBM AT or compatible computer, you *must* run the computer's setup program. This chapter explains how and provides some examples.

If you have an IBM PC, XT, or compatible computer or have added only expanded memory, you don't need to run the computer's setup program. Skip this chapter and turn to Chapter 9.

### **What's the setup program?**

Most IBM AT-compatible computers come with a setup program that lets you tell the computer about system options, including how much conventional and extended memory you have.

Although the setup programs for these computers are similar, the instructions for starting them differ. This chapter provides specific instructions for both the IBM AT and COMPAQ 286 computers and more general instructions for compatible computers.

### **When to run setup**

After you put the Above Board into the computer and run the SETBOARD program, run the computer's setup program. After you have run the setup program, you can run the Above Board SOFTSET program.

---

## Starting setup for an IBM AT

To start the setup program for an IBM AT, put your IBM Diagnostics diskette in drive A and restart your computer (by pressing Ctrl-Alt-Del). When the diagnostics menu appears, choose the setup option.

## Starting setup for a COMPAQ 286

To start the setup program for a COMPAQ 286, put your COMPAQ User Programs diskette in drive A, and restart your computer (by pressing Ctrl-Alt-Del). Then type

```
A:TEST
```

and press Enter. When the diagnostics menu appears, choose the setup option.

## Starting setup for compatible computers

Refer to the manual that came with your computer for instructions on starting its setup program.

## What to tell setup

When the setup program asks how much *base memory* is in your computer, it's asking for the amount of *conventional memory*. When the setup program asks how much *expansion memory* is in your computer, it's asking for the amount of *extended (OS/2) memory*. Type in an extended memory address in 128K byte increments.

---

Remember -- conventional memory is the memory between 0 and 640K bytes. Extended memory is the OS/2, XENIX, or VDISK memory above 1M byte. The computer's setup program doesn't need to know about *expanded memory*.

▼ **NOTE** *If you do not run SETUP correctly, your computer may give you a memory size error. If this happens, rerun setup.*

The following three examples should help you understand the terms used for different types of memory.

#### **Example 1 -- for DOS users who don't use VDISK**

**Background information.** Most DOS users should fill their conventional memory to 640K and use the rest of the Above Board's memory as expanded memory.

**Your computer.** Before adding an Above Board, your computer contained 512K bytes of conventional memory and no extended or expanded memory.

**Your Above Board.** Your Above Board contains 8M bytes. Use the SETBOARD program to provide conventional memory from 512K to 640K and to provide no extended memory. This assigns 128K bytes of Above Board memory to conventional memory, leaving the rest for expanded memory.

**What to tell setup.** When setup asks about base memory, type 640. When it asks about expansion memory, type 0. Don't worry about the 8064K bytes of expanded memory. The computer's setup program doesn't care about the expanded memory on your Above Board.

---

### **Example 2 -- for DOS users who use VDISK**

**Background information.** If your computer already contains 640K bytes (the maximum amount) of conventional memory, you can add only expanded memory or extended memory. Suppose that you want to use VDISK for extended memory RAM disks rather than the Intel RAM disk software. For this example, assume you want 4.25M bytes of extended memory (for the VDISK RAM disk) and 3.75M bytes of expanded memory.

**Your computer.** Before adding an Above Board, your computer contained 640K bytes of conventional memory and no extended or expanded memory.

**Your Above Board.** Your Above Board contains 8M bytes. Use the SETBOARD program to provide extended memory from 1M byte to 5.25M bytes. This assigns 4352K bytes of Above Board memory to extended memory, leaving 3840K bytes for expanded memory.

**What to tell setup.** When setup asks about base memory, type 640. When it asks about expansion memory (remember that *expansion* memory is *extended* memory), type 4352. Don't worry about the 3840K bytes of expanded memory. The computer's setup program doesn't care about the expanded memory on your Above Board.

### **Example 3 -- for XENIX and OS/2 users**

**Background information.** XENIX and OS/2 can't use expanded memory, but they do use extended memory. Set your Above Board to use all of its memory as extended memory. (Extended memory can be provided in blocks of 128K bytes.)

---

**Your computer.** Before adding an Above Board, your computer contained 1M byte of memory configured as 640K bytes of conventional memory and 384K bytes of extended memory.

**Your Above Board.** Your Above Board contains 8M bytes. Use the SETBOARD program to provide extended memory from 1408K bytes (1024K + 384K) to 9600K bytes (9216K + 384K). This assigns 8M bytes to extended memory.

**What to tell SETUP.** When SETUP asks about base memory, type 640. When it asks about expansion memory, type 8192 (for 8M bytes).

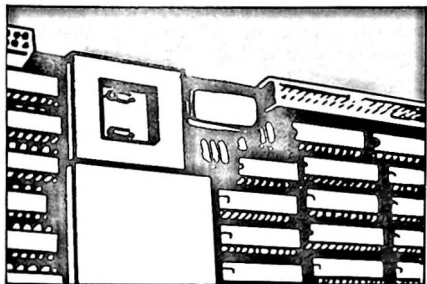
### **Where to go from here**

Answer the questions asked by the setup program. When setup is finished, you have three alternatives:

- If you use extended memory, not expanded, you're finished installing the Above Board. You can skip the rest of this manual.
- If you're a DOS user, consider running the TESTAB program described in Chapter 9. It can pinpoint any non-functioning RAM chips. Then, if you use expanded memory, run the Intel SOFTSET program described in Chapter 10. After you've run SOFTSET, you can run the CHKMEM program, described in Chapter 11, to verify the amount of memory you have.

- 
- If you're a DOS user in a hurry to use expanded memory, turn to Chapter 10. It tells how to run the Intel SOFTSET program. SOFTSET copies the Above Board software to your system disk so your programs can use the Above Board's expanded memory.

# Running TESTAB



## Chapter 9

# 9

---

## RUNNING TESTAB -- THE ABOVE™ BOARD'S CONFIDENCE TESTS

TESTAB (the confidence tests) helps ensure that the Above Boards you've installed are ready to operate the way you expect them to. TESTAB checks whether the RAM (memory) chips on the Above Board are working properly.

During the tests, the screen displays pictures of the board, the board's serial number, and the columns of chips on each board. When TESTAB locates a bad chip it highlights the chip on the display, summarizes the problem, and explains how to fix the problem.

▼ **NOTE** *TESTAB runs only under DOS. If you normally use OS/2 or XENIX, you'll need to switch temporarily to DOS if you want to run the confidence tests.*

### Before you begin

Before you begin, make certain you've completed one of the Hardware Worksheets (see Chapter 5 or Appendix C). You'll need this information to answer the questions TESTAB asks. Also, keep these suggestions in mind before running TESTAB:

- **Save any data that is stored in your computer's RAM** (in a print buffer or RAM disk, for example). TESTAB tests all the RAM on your Above Board, so save the data before starting the tests.
- **The system unit cover must remain in place during the tests.** If you need to look at a board to remedy a problem, wait until the tests are complete. Then, be sure you turn off your computer and unplug it before removing the cover.



---

## Starting the confidence tests

Start the confidence tests by following these steps:

- 1 Restart your computer using a DOS disk that has no application programs on it.
- 2 Insert a copy of the Intel diskette in drive A. Then type:

```
A:TESTAB
```

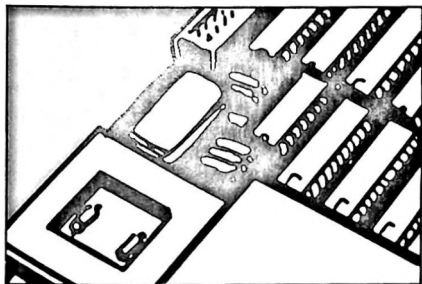
and press the Enter key.

The confidence tests will begin running. They're self-explanatory -- just follow the instructions. Throughout the confidence tests, TESTAB will ask you for facts about your computer and your Above Boards. Keep the hardware worksheet you filled out in Chapter 5 or Appendix C handy. It contains the information that you will need to give TESTAB.

When you complete the confidence tests, go to Chapter 10 for information on running Intel's SOFTSET program.

▼ **NOTE** *If you have an emulation or Local Area Network (LAN) card installed in your computer, TESTAB may report every other row of chips defective. To accurately test the Above Board, remove the emulation or network card and rerun TESTAB. Insert the emulation or network card after the confidence tests are complete.*

# Running SOFTSET



Chapter 10

10

---

## RUNNING THE SOFTSET PROGRAM

SOFTSET is an interactive installation program that helps you set up the Above Board software on a diskette or a hard disk.

- ▼ **NOTE** *The Above Board software (that SOFTSET loads) runs only under DOS. If you normally use XENIX or OS/2, skip this chapter.*

*If you wish to set up the Above Board only for conventional and extended memory, you do not need to install the software, and you can skip this chapter.*

### What does SOFTSET do?

SOFTSET copies the Above Board software onto a diskette or hard disk. It also adds commands to the AUTOEXEC.BAT and CONFIG.SYS files on your system disk. These commands allow the Above Board software to run automatically each time you turn on or restart your computer.

- ▼ **NOTE** *SOFTSET saves your original AUTOEXEC.BAT and CONFIG.SYS files under the names AUTOEXEC.OLD and CONFIG.OLD. If you already have files named AUTOEXEC.OLD and CONFIG.OLD, rename them before you run SOFTSET.*

SOFTSET differs from most application programs in that you use it less often. Typically, you use it only once to install the Above Board software on a diskette or hard disk. However, you can run SOFTSET again if you want to change the size of a RAM disk or print buffer.

Throughout the installation process, SOFTSET describes the choices you'll be making and, when appropriate, offers guidelines to help you:

- 
- prepare your system disk to use the Above Board's expanded memory.
  - set up one or two RAM disks (if desired).
  - set up a print buffer
  - select either a complete or abbreviated version of the expanded memory tests that run whenever you restart (Ctrl-Alt-Del) your computer.
  - set up the Above Board's memory as mappable conventional memory.
  - relocate the expanded memory device driver.

### **Before you use SOFTSET**

The following subsections describe what you should do before you start the SOFTSET program. Before running SOFTSET:

- be sure your computer meets the requirements to run SOFTSET (listed in the next section).
- decide where to install the Above Board software -- on a diskette or on a hard disk.
- be sure you're using the most current version of the Above Board software.
- back up the Above Board software (if you haven't already done so).
- save any data you may have in a print buffer or RAM disk.

---

▼ **NOTE** *We recommend you boot from a plain DOS diskette. A plain DOS diskette contains neither application programs nor an AUTOEXEC.BAT file.*

### **Requirements**

To use SOFTSET, your computer must contain the following hardware and software:

- Either two diskette drives or one diskette drive and a hard disk.
- DOS version 3.0 or a more recent version.
- At least 256K bytes of conventional memory.
- At least one Above Board.

### **Where to Install the Above™ Board software**

You must install the Above Board software on a system disk (*a system disk contains DOS and is the one you use to start or restart your computer*). If you start your computer from a diskette, install the Above Board software on that diskette. If you start your computer from a hard disk, install the Above Board software on it.

### **Check the date on the Above™ Board software diskette**

*If you have more than one Above Board software diskette, make sure you use the Intel diskette with the latest date on the label.*

---

## Back up the Above™ Board software

If you haven't already done so, make a backup copy of the Intel diskette. (Make a backup *diskette* -- don't backup the Intel software on your hard disk.) Always use this backup copy when you run SOFTSET.

Refer to the DOS manual that came with your computer if you don't know how to copy a diskette.

**▼ NOTE** *For IBM AT or compatible computers: If you receive a memory size error message when you turn on or restart your computer, turn it off, insert the diskette that contains your computer's setup program in drive A, and run the computer's setup program (described in Chapter 8 of this manual).*

### Remove any data in a print buffer or RAM disk

Don't start SOFTSET while you have data in a print buffer or RAM disk. When SOFTSET quits, it restarts your computer and erases the contents of your print buffer and RAM disk.

To avoid losing data from a print buffer or RAM disk, follow these two rules:

- If you have data in a print buffer, let the printer finish printing the data before starting SOFTSET.
- If you have data in a RAM disk, copy the data to a diskette or hard disk before starting SOFTSET.

## Starting SOFTSET

This section describes how to start the SOFTSET program.

- 1 With your screen displaying the DOS prompt, insert a copy of the Intel diskette into drive A.

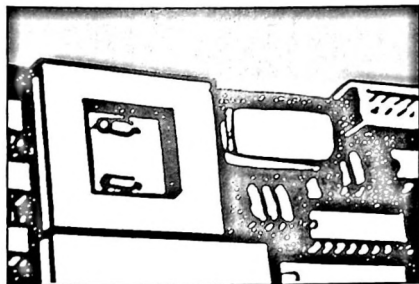
---

**2** Type:

**A:** SOFTSET

and press Enter. Follow SOFTSET's directions and answer the questions. SOFTSET does the rest.

# Running CHKMEM



Chapter 11



---

## RUNNING THE CHKMEM PROGRAM

The CHKMEM program reports the amount of conventional, extended (*IBM AT and compatible computers only*), and expanded memory in your computer. It also tells you how much expanded memory is being used and how much is available for application programs.

Running CHKMEM is optional -- it simply confirms the memory choices you made when you ran SETBOARD.

- ▼ **NOTE** *CHKMEM runs only under DOS. If you normally use OS/2 or XENIX, temporarily switch to DOS to run CHKMEM.*

### Starting CHKMEM

Follow these steps to start CHKMEM:

- 1 Restart (Ctrl-Alt-Del) your computer using the diskette or hard disk on which you installed the Above Board software.
- 2 Insert the Intel diskette in drive A, type

A:CHKMEM

and then press Enter.

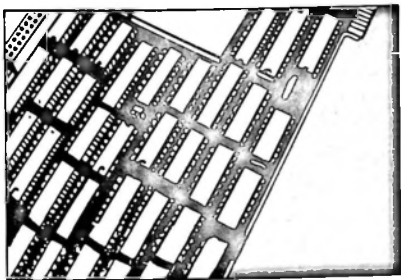
### If the results aren't what you expected

CHKMEM isn't a diagnostic or confidence test program. If the amount of memory that CHKMEM displays differs from what you expected, run the confidence tests described in Chapter 9.

---

▼ **NOTE** *Don't use CHKMEM if you're using an expanded memory emulator such as ILIM386 that's supplied with the Inboard 386. CHKMEM may display invalid results when used with expanded memory emulators.*

# RAM DISKS



Chapter 12

112

---

## **RAM DISKS**

This chapter explains how a RAM disk can help you use your computer more efficiently. To set up a RAM disk, you need either to run the SOFTSET program, which is described in Chapter 10 or to install the software manually, as described in Appendix F.

If you're unfamiliar with RAM disks, read this chapter. If you've used RAM disks before, skip to the next chapter.

### **What's a RAM disk?**

A RAM disk is part of your computer's random access memory that the Above Board software uses to emulate a disk drive. To you, and to your software, the RAM disk appears to be an ordinary drive.

But unlike an ordinary disk drive, a RAM disk has no mechanical parts, so it works much faster -- up to 10 times faster than a diskette drive and twice as fast as a hard disk.

### **Differences between ordinary disks and RAM disks**

Here are the differences between ordinary diskettes or hard disks and RAM disks.

#### **RAM disks are faster**

RAM disks are up to 10 times faster than diskettes and twice as fast as hard disks.

---

### **RAM disks store data temporarily**

When you store a file on a RAM disk, the file remains there only until you turn off the power or restart your computer (by pressing Ctrl-Alt-Del). If you want to save the file, you must copy it from the RAM disk to a diskette or hard disk.

### **You define a RAM disk's size**

Although hard disks and diskettes are available only in fixed sizes, a RAM disk can be as large or small as you like.

The size of a RAM disk is limited only by the amount of RAM you're willing to dedicate to it. A RAM disk in expanded memory can be as large as 8M bytes.

When you create your RAM disks, remember that a typical low-density diskette can contain 360K bytes of data. A RAM disk needs the same amount of room for the same amount of data. For example, if you want a RAM disk to hold up to two floppy diskettes' worth of data, make the RAM disk at least 720K bytes.

### **RAM disks are formatted automatically**

You don't have to format a RAM disk before putting data on it -- the Above Board software does it when it creates the RAM disk. In contrast, if you're using a new diskette in an ordinary disk drive, you must invoke the DOS FORMAT command to prepare the diskette before storing data on it.

---

## When is a RAM disk useful?

A RAM disk is especially useful with application programs that frequently read from and write to the disk. You can tell how often a program accesses a disk drive by keeping track of how frequently the disk drive's light comes on. (When the light comes on, the computer is reading from or writing to the disk.)

If a disk drive is often busy while a particular program is running, a RAM disk can speed up that program. The next few sections describe situations in which you may want to use a RAM disk.

### Storing an application program on a RAM disk

Many application programs work faster if you store them on a RAM disk.

How can you tell whether your program will run faster from a RAM disk? Look for both these characteristics:

- 1 The program requires the program diskette to be in a drive (or on a hard disk) the *entire* time the program is running.
- 2 The drive containing the program is often busy.

If your program has *both* these characteristics, try running it from a RAM disk.

Microsoft Word, for example, runs faster if you store it on a RAM disk. Word often accesses the drive where its program resides to read parts of the word processor into memory or to store information in temporary files.

If you copy Word to a RAM disk before running it, the program accesses the RAM disk instead of the diskette or hard drive. As a result, Word runs faster.

---

Microsoft Word's manual gives specific instructions for using Word with a RAM disk. Some other application programs' manuals also contain information about RAM disks.

The following popular programs, along with many others, run faster when the program is on a RAM disk:

dBase II	Volkswriter Deluxe
dBase III	Word
DisplayWrite 2	Word Perfect
MultiMate	WordStar

### Storing data on a RAM disk

Some programs run faster when you store the data, rather than the program, on a RAM disk. To identify such programs, look for both these characteristics:

- 1 The program requires that a data disk be kept in one of the drives the *entire* time the program is running.
- 2 The drive containing the data disk is often busy.

If your program has *both* these characteristics, try storing its data on a RAM disk.

The following popular programs, along with many others, will run faster when their data is stored on a RAM disk:

dBase II	Word
dBase III	Wordstar
pfs:file	

---

▼ **NOTE** *Before you store data files on a RAM disk, realize that the files will be destroyed if a power failure occurs or if you turn off your computer without copying the files to a hard disk or diskette. Unless you have a battery-backup for your power supply, you should frequently copy your data files from the RAM disk to an ordinary disk.*

### **Creating one RAM disk for programs and one for data**

If your application accesses two disk drives heavily, you may want to set up two RAM disks -- one for the application program and one for data files.

### **Storing several programs on a RAM disk**

Because the Above Board software lets you create huge RAM disks in expanded memory, a RAM disk is an ideal place to store application programs you run frequently.

For example, if you work with both dBase II and DisplayWrite 2, you may want to copy them to large RAM disks in expanded memory when you first turn on your computer. With both programs on RAM disks, you can switch from one to the other rapidly, without changing diskettes.

### **When is a RAM disk not useful?**

In some situations a RAM disk doesn't help. Here are two examples.



---

### **Programs that seldom access the disk**

A RAM disk can't speed up a program that seldom reads from or writes to disk. For instance, both the program and data files for 1-2-3 reside in RAM, so the program rarely accesses a disk. A RAM disk won't speed up 1-2-3.

### **Some copy-protected programs**

Some copy-protected programs check the diskette to make sure it's the original program diskette. Most of these programs can't be run from a RAM disk.

Not all copy-protected programs work this way. For example, Microsoft Word versions 2.1 and earlier are copy-protected, but they'll work if you copy them to a RAM disk. If you're unsure about the program you're using, check your program's manual or call the manufacturer.

### **How many RAM disks can be created?**

The SOFTSET program (described in Chapter 10) lets you create up to two RAM disks. If you need more, Appendix F explains how to create more.

### **Using Above™ Board RAM disks with VDISK RAM disks**

Above Board RAM disks work fine with VDISK RAM disks. VDISK RAM disks run in *extended* or *conventional* memory whereas Above Board RAM disks run in *expanded* memory. RAM disks are not typically set up in conventional memory because of the limited memory size. Refer to Chapter 2 or the glossary for a definition of extended and expanded memory. Refer to your DOS manual for information about VDISK.

---

## Assigning a drive letter to a RAM disk

RAM disks are created when you start or restart the computer from the system disk the SOFTSET program prepared. When creating a RAM disk, DOS finds out how many drives your computer has and automatically assigns the next available letter to your RAM disk.

Here are two examples. In a computer with two diskette drives (A and B) and no hard disk, the first RAM disk is drive C. In a computer with one hard disk (drive C), the first RAM disk is drive D.

The next two paragraphs are technical, but you'll want to read them if you're using a device driver, such as a Local Area Network (LAN) or a Bernoulli Box, that adds disk drives to your system.

If you're using a device driver that provides additional "disk drives" to your computer, the Above Board RAM disks will be assigned the next available letters after these drives. For example, if your computer has one hard disk (C) and two LAN drives (D and E), the first Intel drive would be drive F.

The position of the DEVICE=QUIKMEM commands in the system disk's CONFIG.SYS file determines the drive letters that are assigned to each RAM disk. SOFTSET inserts the DEVICE=QUIKMEM commands at the end of the CONFIG.SYS file. If you put the DEVICE=QUIKMEM commands before the LAN (or other device driver) commands, the RAM disks will be assigned drive letters preceding those assigned to the other devices. Appendix F describes the QUIKMEM command.

---

## Copying files to a RAM disk

A RAM disk can't save you time unless it contains files. If the RAM disk is large enough, you can copy data or almost any application program to it. You can copy files to a RAM disk in one of two ways.

- ▼ **NOTE** *Because DOS views a RAM disk as another disk drive, each RAM disk is limited to 128 files in its root directory -- just as other disk drives are. If you need to put more than 128 files in a RAM disk, you must create subdirectories (using the DOS MKDIR command) on the RAM disk. Refer to your DOS manual to learn how to make subdirectories.*

### Typing COPY commands yourself

Explicitly copy each file to the RAM disk. Type the DOS COPY command before starting the application program. For instance, to copy a file called SAMPLE.DOC from drive A to a RAM disk called drive D, use this command:

```
COPY A: SAMPLE.DOC D:\
```

Typing COPY commands works well for data files because you may not know what data file you need until just before you start working.

### Putting COPY commands in a batch file

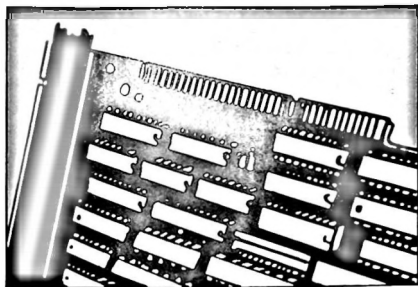
Putting the DOS COPY commands in a batch file saves time because you don't need to type all the commands each time you run the program. The batch file automatically copies the files to your RAM disk when you run the batch file.

Refer to the DOS manual for more information about batch files.

---

Batch files work well for copying program files when you want to run programs from a RAM disk. Generally, you know what files the program needs in order to run, so you can create a batch file to copy them.

# The Print Buffer



Chapter 13



---

## THE PRINT BUFFER

This chapter explains how the print buffer works and how you can use it to control printing. To set up a print buffer, you must run the SOFTSET program, which is described in Chapter 10.

### What is a print buffer?

The print buffer is Intel software that lets you print a document without tying up your computer. While your printer is printing, you can continue working -- and making effective use of your time.

### When is a print buffer useful?

When you're working at your computer, it can be annoying to send a document to the printer, then wait for the printer to finish so you can go back to what you were doing. Although some programs are capable of sending documents at high speed, most printers receive data slowly.

A print buffer solves this problem by turning some of your computer's memory into a data reservoir. Data pours in from the application program to memory, remains in memory until the printer is ready, and then flows to the printer.

Your program works faster when it sends data to memory because the memory, unlike the printer, can accept data rapidly. With a print buffer, your computer is free for other chores as soon as your program finishes sending a document to the print buffer.

---

While you go on working, the data is temporarily stored in memory until the printer is ready for it. The print buffer sends the data to the printer automatically, even though you're doing other work with the computer.

▼ **CAUTION** *If you turn off or restart your computer before your document is printed, you'll lose any portion of the document remaining in the print buffer.*

Although using a print buffer is usually a good idea, it involves two tradeoffs: first, the memory set aside for the print buffer can't be used for other purposes, and second, some printers will run more slowly.

To make the most of your computer, you need to decide:

- how much memory you want to devote to the print buffer. (As a rule of thumb, allow 4K bytes of memory for each page of text and 256K bytes for each page of graphics.)
- whether a print buffer will work to your advantage. (Refer to the next section.)

▼ **NOTE** *You can create only one print buffer on your computer.*

## **When is a print buffer not useful?**

In some situations, a print buffer won't make your computer available for other work more quickly.

### **Programs with a built-in print buffer**

If a program has a built-in print buffer, you can't add a second print buffer. Framework, DisplayWrite 2, Multimate, and Microsoft Windows are examples of programs that provide their own print buffers.

---

### **Printers with large built-in buffers**

If your printer has a built-in buffer large enough to hold your documents, the Above Board print buffer won't help free up your computer any sooner. For example, some Hewlett-Packard LaserJet printers have very large print buffers. Unless you're printing graphics or long documents, you'll see little benefit from adding another print buffer.

### **Computers attached to a local area network (LAN)**

The print buffer does not work with LAN software.

### **Computers with a small amount of expanded memory**

If you routinely send big documents to the printer, you should set aside a proportionately large print buffer. Otherwise, you'll see some delay when your print buffer becomes full.

A print buffer of 16K bytes, for example, can hold only about four pages of text. With a buffer this size, the first half of an eight-page document would fill the print buffer. Then your screen would be tied up, just as though you had no print buffer, while you waited for the print buffer to accept the second half.

### **Controlling the printer -- the print buffer command menu**

After the print buffer is installed, you can call the print buffer command menu (shown in Figure 13-1) by pressing the PrtSc key. This menu lets you control the printer's activities.



- ▼ **NOTE** Any program that disables the *PrtSc* key will prevent you from accessing the print buffer command menu. The print buffer will still work, but you won't be able to use the commands in the menu to control the printer.

You can't use the DOS *PRINT* command with the Above Board print buffer. If you want to send a file to the printer from DOS, use the command:

`COPY filename PRN`

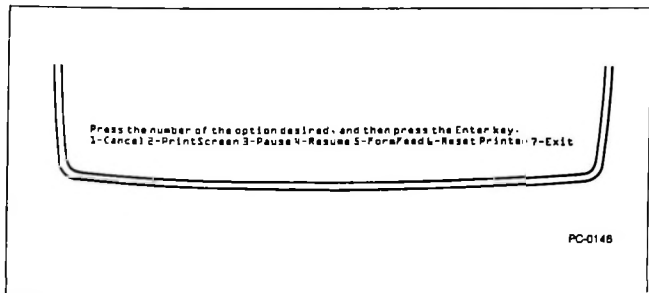


Figure 13-1 *Print buffer command menu*

### Compatible display adapters

Intel has verified that the following types of display adapters work with the print buffer command menu:

- IBM Monochrome Display Adapter
- Hercules Monochrome Graphics Adapter
- IBM, COMPAQ, Zenith, AT&T, and Hercules Color Graphics Adapters

- 
- IBM Enhanced Graphics Adapter
  - IBM VGA (Video Graphics Array)

▼ **NOTE** *The print buffer will work with other adapters, but the print buffer command menu may not function correctly unless those boards are 100%-compatible with one of the display adapters listed here.*

If you have an adapter different from those listed, you must prevent the print buffer command menu from appearing. When you set up your print buffer by running the SOFTSET program, you'll be asked to identify your display adapter. One option you'll be offered is "other." Choosing this option prevents the menu from appearing. Your print screen key and the print buffer will operate as they always have.

▼ **NOTE** *Select "other" if you're using a Hercules Graphics Plus Adapter.*

### Using print buffer commands

Once you've set up a print buffer, your program will send documents to the printer automatically through the print buffer. Most of the time, that's exactly what you'll want it to do.

But occasionally, after sending a document to the printer, you may change your mind. You may want to cancel a document that's printing or stop to put a fresh ribbon on the printer.

To make this easy, the print buffer comes with a set of commands similar to the function buttons on a printer. You can use these commands at any point in your work. Just press the PrtSc key, and the menu in Figure 13-1 will appear in the bottom two lines of your screen.

---

With the exception of PrintScreen, these commands affect only the buffered printer. (If your computer is attached to more than one printer, refer to the section "Assigning the print buffer to a printer" to find out which printer is buffered.)

When the command menu appears, it suspends the flow of data from your application program to the print buffer and gives you a way to act on the data residing in the buffer. However, any data already in the print buffer continues to flow to the printer.

To select a command, type the number of the command listed in the menu, then press the Enter key. Once a command is completed, you can either choose another command or exit the menu (by choosing option 7).

The menu offers these seven commands:

**1** **Cancel** -- erases the entire contents of the print buffer. Cancel removes only what's in your computer's print buffer. Data that has already passed from the buffer to the printer (or to the printer's built-in buffer) is printed. Data waiting to be passed from the application program to the print buffer will be sent as soon as you exit the command menu.

▼ **HINT** *Cancel may not stop the entire print job. It erases only data already in your print buffer. To cancel a print job, first tell the application program to stop printing. Then use the Cancel option from the print buffer's command menu.*

**2** **PrintScreen** -- prints whatever was displayed on your screen before you called up the menu. (PrintScreen doesn't print the menu.) PrintScreen prints the screen, just as the PrtSc key did before you installed the print buffer. PrintScreen also starts your printer if you used Pause to stop it.

---

If the print buffer is associated with a printer other than LPT1, PrintScreen bypasses the print buffer and sends the screen contents to LPT1. (For details, refer to the section "Assigning the print buffer to a printer.")

▼ **HINT** *If LPT1 is the buffered printer, and an application program is sending a document to the buffer, PrintScreen will interrupt it and place the screen contents in the middle of the document. If you want the screen contents on a separate page, either wait until the application finishes sending the document to the buffer, or use the FormFeed command before and after you use PrintScreen.*

**3** **Pause** -- temporarily stops the print buffer from sending data to the printer. To continue printing, use Exit or Resume. PrintScreen and FormFeed also cause printing to continue.

▼ **HINT** *Pause offers an easy way to temporarily eliminate printer noise. It's also a handy way to stop the printer so you can change ribbons or take care of paper jams.*

**4** **Resume** -- continues printing the document exactly where it left off when you used Pause. Resume has no effect unless you've already used Pause.

**5** **FormFeed** -- puts a form feed at the end of the data currently in the buffer. FormFeed tells the printer to put the next line in the buffer at the top of a new page. It also starts your printer again if you used Pause to stop it.

If the print buffer is empty, the form feed occurs immediately. If the buffer contains data, the form feed occurs after the data in the buffer is printed.

---

▼ **HINT** *FormFeed is a handy way to separate documents. To avoid putting blank space in the middle of your document, make sure the application program has finished sending a document to the print buffer before you issue the FormFeed command.*

**6 ResetPrinter --** empties the Above Board print buffer.

For parallel printers, `ResetPrinter` does the equivalent of turning your printer off and immediately back on. It returns your parallel printer to its original state. It clears all special settings (such as boldface, different character pitch, and unusual character sets), empties the printer's built-in buffer and the Above Board's print buffer, and resets the top-of-form.

You can't reset a serial printer with software. For serial printers, `ResetPrinter` empties the Above Board print buffer, leaves the printer alone, and displays an error message.

▼ **HINT** *If a control character causes your parallel printer to print strange characters, run off the end of the page, or stall, `ResetPrinter` will take the printer back to normal. Just remember to check the top-of-form and other settings before you resume printing.*

**7 Exit --** returns you to the program you were using when you pressed the `PrtSc` key. It also removes the print buffer command menu from your screen. Using `Exit` after `Pause` causes printing to resume.

---

## Assigning the print buffer to a printer

The print buffer is always assigned to one printer.

For a serial printer, you explicitly assign the buffer to a printer when you run the SOFTSET program (refer to Chapter 10).

For a parallel printer, you implicitly assign the buffer to the printer. Each time you start your computer or restart it (by pressing Ctrl-Alt-Del), the first thing you print on a parallel printer determines the assignment. The print buffer is assigned to the first parallel printer you use. (For example, sending your first document to LPT3 assigns the buffer to LPT3.) However, if you issue one of these three print buffer commands *before* printing a document, the print buffer is assigned to LPT1:

**2 PrintScreen**

**5 FormFeed**

**6 ResetPrinter**

Only the documents sent to the buffer's assigned printer go through the print buffer. Any documents sent to another printer go to that printer directly without using the print buffer. To reassign the print buffer for parallel printers, restart your computer by pressing Ctrl-Alt-Del.

If you've decided to set up a print buffer, you'll need to run the SOFTSET program. (Refer to Chapter 10 for details.) It's easy to do, and your efforts will be paid back in the increased use of your computer.

---

## Buffering serial printers

If you intend to buffer a serial printer, use the DOS MODE command to set up your serial port before you print anything. Refer to Chapter 15 for more information.

## Handling messages

When a print buffer command fails to execute properly, the print buffer command menu changes to display a message. When a message appears, refer to the following section to find the cause of the problem. Then press any key to return to the print buffer command menu. Once back at the menu, you can reissue the command that failed, or you can exit the menu by choosing option 7.

## Messages

As you use the Above Board print buffer software, numbered messages may appear on your screen. They indicate problems you'll need to address.

This section lists the print buffer messages in numerical order. Each entry explains why the message appeared and describes what you should do.

If you have trouble correcting a problem, contact your dealer or Intel's Customer Support. Appendix B explains how to reach Customer Support.

### Print Buffer Msg 500

*[Option] failed--check printer. To go on press any key.*

---

**Cause:** The print buffer was unable to execute either the PrintScreen (2) or FormFeed (5) option because the printer wasn't ready.

**Action:** Check the printer. Make sure that it has enough paper, that it's turned on and on-line, and that all cables are plugged in tightly.

If the error was triggered by a PrintScreen command, make sure the printer is LPT1. Pressing any key returns you to the print buffer command menu, where you can either retry the command or exit the menu.

### **Print Buffer Msg 507**

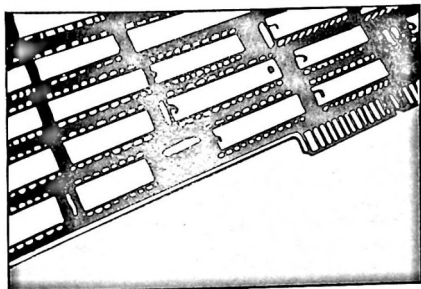
*Can't reset serial printer. To go on, press any key.*

**Cause:** You chose the ResetPrinter option from the print buffer command menu. However, your printer is serial (as opposed to parallel), and serial printers can't be reset.

**Action:** This is an advisory message, not an error message. You aren't required to *do* anything. The contents of your print buffer have been erased.



# Parallel Port



Chapter 14

14

---

## PARALLEL PORT

The Above Board Plus 8 I/O has a parallel port that the Above Board Plus 8 does not. This chapter explains the capabilities of a parallel port. If you're already familiar with parallel ports, you can skip this chapter.

### What is a parallel port?

A parallel port is a connector to which you can attach an IBM-compatible parallel printer or other parallel device. Figure 14-1 shows the parallel port provided by the Above Board Plus 8 I/O. (The Above Board Plus 8 doesn't have a parallel port.)

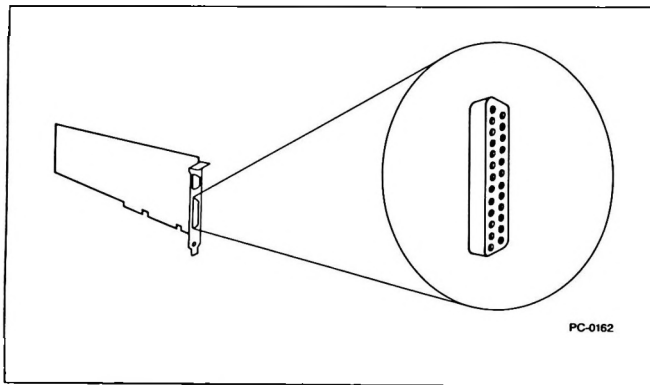


Figure 14-1 *Above™ Board Plus 8 I/O's parallel port*

---

## **Is your printer parallel?**

Before you connect a printer to the parallel port, make sure that the printer is parallel. Check the printer's manual if you aren't sure. If your printer is serial, turn to Chapter 15.

Examples of parallel printers include the IBM Graphics Printer, Epson FX-80, and most other dot-matrix printers. Many letter-quality printers are also parallel -- the NEC 3550 Spinwriter, for example.

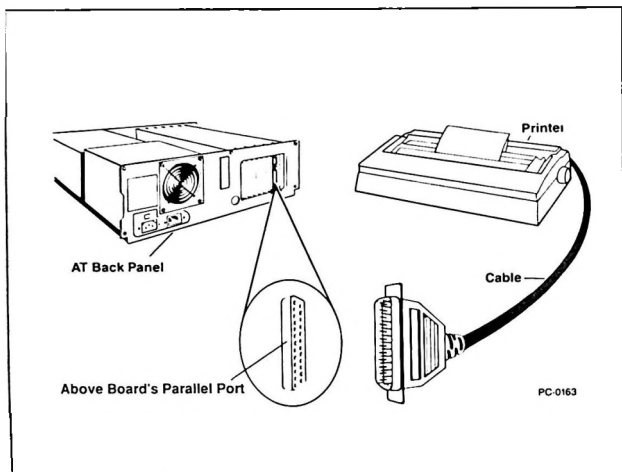
## **Buying a cable**

If you don't already have a cable, ask for the standard IBM Parallel Printer Cable or another manufacturer's equivalent. Your dealer can tell you which cables will work.

## **Connecting the printer**

Once the Above Board is in the computer, attach the cable's 25-pin connector to the parallel port. The larger of the Above Board's two connectors is the parallel port.

Figure 14-2 shows how to plug the cable into the parallel port. The connectors are D-shaped, so you can attach them in only one way.



**Figure 14-2** *Attaching a printer to a parallel port*

Be sure to secure the cable to the parallel port with its attached screws. If you don't, bumping the cable could loosen the connection, causing your printer to suddenly stop working properly.

### **Naming or disabling the parallel port**

DOS lets you connect up to three parallel printers to the computer at one time. To distinguish among these printers, you must name the ports to which they're connected.

---

DOS reserves three names (LPT1, LPT2, and LPT3) for parallel ports based on the number of parallel ports in the computer and the I/O address (3BC, 378, or 278) that each port uses. You can have up to three parallel ports in your computer only if LPT1 is on the IBM Monochrome Display Adapter or its equivalent. Otherwise, DOS limits your computer to two parallel ports (LPT1 and LPT2). When you turn on or restart your computer, DOS checks for parallel ports first at I/O address 3BC, then at 378, and finally at 278. The first parallel port it finds becomes LPT1, the second becomes LPT2, and the third becomes LPT3. The SETBOARD program (described in Chapter 7) lets you choose the name of the Above Board's parallel port.

You cannot set the Above Board or any I/O card to I/O address 3BC. This I/O address is reserved for a video card that contains a parallel port (such as the card for the IBM Monochrome Display adapter).

If you have only one parallel port in the computer, DOS always names it LPT1, regardless of the I/O address it uses. If you have two parallel ports, DOS assigns LPT1 to the port using the highest address. (For example, if the ports use 378 and 278, the port at 378 becomes LPT1 and the one at 278 becomes LPT2).

If you have three parallel ports installed, the port at 3BC becomes LPT1, the one at 378 becomes LPT2, and the one at 278 becomes LPT3.

If your computer can't contain any additional parallel ports (you already have three), use SETBOARD to disable the Above Board's parallel port. This will let you install the Above Board without exceeding DOS's parallel port limit. SETBOARD is discussed in Chapter 7.

---

## Using your printer

Once the Above Board is installed and the printer is connected, you can print information in several ways. Here are two examples.

### Printing from an application program

Most application programs can send information to your printer. Before you tell your program to start printing, be sure to identify the port to which the printer is connected (LPT1, LPT2, or LPT3). If you don't tell the program which printer to use, most programs assume LPT1.

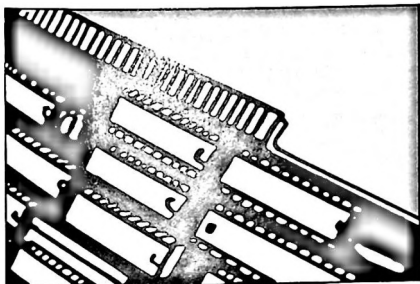
### Printing an ASCII file

To print the contents of an ASCII file, use the DOS COPY command. For example:

```
COPY A:LETTER.TXT LPT1:
```

prints the contents of a file (located on drive A) called LETTER.TXT to the printer attached to LPT1.

# Serial Port



Chapter 15

15

---

## SERIAL PORT

The Above Board Plus 8 I/O has a serial port -- the Above Board Plus 8 doesn't. This chapter explains the capabilities of the Above Board Plus 8 I/O's serial port.

If your board doesn't have a serial port or if you're already familiar with serial ports, skip this chapter. Refer to Chapter 2 if you're not sure whether your board has a serial port.

▼ **NOTE** *The Above Board Plus 8 I/O's serial port connector is the 9-pin style rather than the 25-pin style. If your serial device has a 25-pin cable, your dealer can sell you an adapter that converts it from 25 pins to 9.*

### What is a serial port?

A serial port lets your computer communicate with serial printers, other computers (using modems), and serial devices such as plotters, mice, and custom laboratory equipment.

### The serial port on the Above™ Board Plus 8 I/O

The Above Board Plus 8 I/O comes with its serial port ready to use. Figure 15-1 shows the location of the serial port on the Above Board Plus 8 I/O.



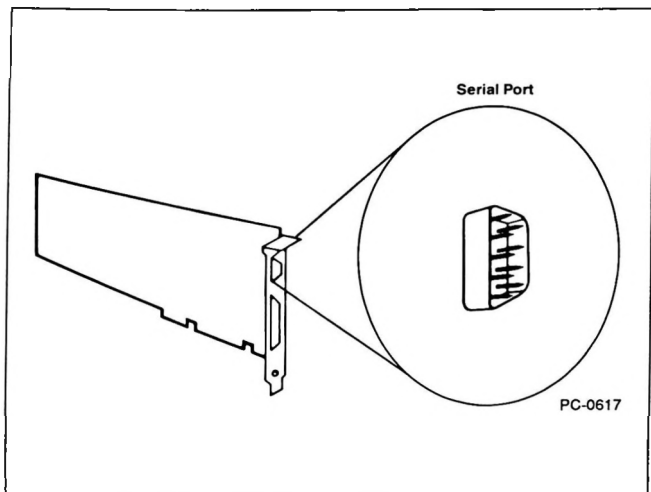


Figure 15-1 *Above™ Board Plus 8 I/O's serial port*

### **Naming serial ports**

DOS lets you put up to two serial ports in your computer. To distinguish between them, DOS names them.

DOS assigns serial port names (COM1 and COM2) based on the number of serial ports in the computer and the I/O address (3F8 or 2F8) that each port uses. When you turn on or restart your computer, DOS checks for serial ports first at I/O address 3F8 then at address 2F8. The first serial port it finds becomes COM1, and the second becomes COM2.

---

If you have only one serial port in the computer, DOS always names it COM1, regardless of the I/O address it uses. If you have two serial ports, the port at 3F8 becomes COM1, and the one at 2F8 becomes COM2.

You must use the SETBOARD program to choose the address of the serial port. (SETBOARD is described in Chapter 7.) If you're adding your computer's first serial port, assign it to address 3F8. If you're adding a second serial port, assign it to the address not being used (usually 2F8).

If your computer had two serial ports before you installed this Above Board, use SETBOARD to disable the Above Board's serial port. This lets you use the Above Board Plus 8 I/O without violating DOS's limit of two serial ports.

▼ **NOTE** *The Above Board can be set for COM3 and COM4. Certain communications applications (such as ProComm) can access these ports directly.*

## Using a serial printer

Before you connect a printer to a serial port, make sure that the printer is serial. If you're not sure, refer to your printer's manual. If the printer is parallel, turn to Chapter 14.

This section explains how to use a serial printer with the Above Board Plus 8 I/O print buffer.

▼ **CAUTION** *Be sure either to run SOFTSET (described in Chapter 10) or set up the software manually (described in Appendix F) before you follow these instructions.*

---

## Letting your application program set up the serial port

Some applications (most often, word processors) can automatically set up the serial port to match the needs of your printer. (Refer to your application program's manual to see if the serial port is set up automatically.) If you use the serial printer only with these programs, don't set up the port yourself. Otherwise, read the next section.

## Setting up the serial port yourself

If your programs don't automatically set up the serial port, you'll need to do it yourself.

Before you set up the port, do a little research. DOS needs to know the protocol parameters for your printer. The protocol parameters are as follows:

- port name (COM1 or COM2)
- baud rate (110, 150, 300, 600, 1200, 2400, 4800, or 9600)
- parity (even, odd, or none)
- databits (7 or 8)
- stopbits (1 or 2)

You can generally find the values for these parameters in the manual that came with your printer.

## Example

This example shows how to set up COM1 for a Hewlett-Packard LaserJet printer.

---

Use the DOS MODE command to set up the port for that printer. For the Hewlett-Packard LaserJet, the command looks like this:

```
MODE COM1:9600,N,8,1,P
```

"COM1" tells DOS which of the two serial ports you're setting up. The LaserJet communicates at 9600 baud, with no parity, 8 databits, and 1 stopbit.

The P tells DOS that you're connecting a printer or plotter to the serial port. (If you're connecting a modem, drop the last comma and the P.)

See your DOS manual for a complete description of the MODE command.

▼ **HINT** *If you set up the serial port yourself, consider adding the MODE command to your AUTOEXEC.BAT file. If you add it, DOS will automatically set up the serial port whenever you turn on or restart the computer using the disk containing that AUTOEXEC.BAT file. To add the command to the AUTOEXEC.BAT file, use DOS's EDLIN or any other editor that can modify ASCII files.*

▼ **CAUTION** *If you're setting up the port for a serial printer, and you plan to use the Above Board Plus 8 I/O print buffer, the order of events is important. First install the software either by running SOFTSET (Intel's installation program) or by installing the software manually to prepare your system disk. Then add the MODE command to the AUTOEXEC.BAT file. Put the MODE command ahead of the QUIKBUF2 command (the print buffer command installed by SOFTSET).*

### **Fooling some application programs**

A few application programs cannot send information directly to COM1 or COM2. Here's how to get around such application programs.

---

You can fool the application into thinking it's communicating with a parallel printer. Use the DOS MODE command to redirect the parallel port to a serial port. For example, MODE LPT1:=COM2 redirects the parallel port LPT1 to the serial port COM2. Then instruct the application to send information to LPT1. The application will send information to LPT1, and DOS will then route the information to COM2 and your serial device.

This means that if you must redirect a port, you'll need two MODE commands: the first to set up the port, and the second to redirect the port. Be sure that both MODE commands come before the QUIKBUF2 command.

**▼ CAUTION** *Redirection slows down your serial device (and your print buffer, if you have one). So use redirection only when your application requires it.*

## Communication with other computers

If you plan to send data over phone lines to other computers, you'll need a modem. A modem translates data from the computer into a form that can be transmitted over phone lines. It also translates data from phone lines back into the form needed by computers.

Although some modems are boards that can be put inside your computer, others are designed to work outside the computer. These external modems can be attached to the Above Board Plus 8 I/O's serial port.

To find out how to attach an external modem to the serial port, refer to the modem's manual. It should also discuss the software required to use the modem.

---

## Connector for the serial port

The Above Board Plus 8 I/O uses a 9-pin connector, not a 25-pin connector, for its serial cable. If you haven't yet purchased a cable for your serial device, buy one with a 9-pin connector. If you already have a cable with a 25-pin connector, your dealer can sell you an adapter that converts it from 25 pins to 9.

Figure 15-2 shows the name and direction of each signal on the Above Board Plus 8 I/O's serial connector. Signals labeled *output* travel out of the computer to the serial device. Signals labeled *input* travel into the computer from the serial device. The ground line is neither an input nor an output.

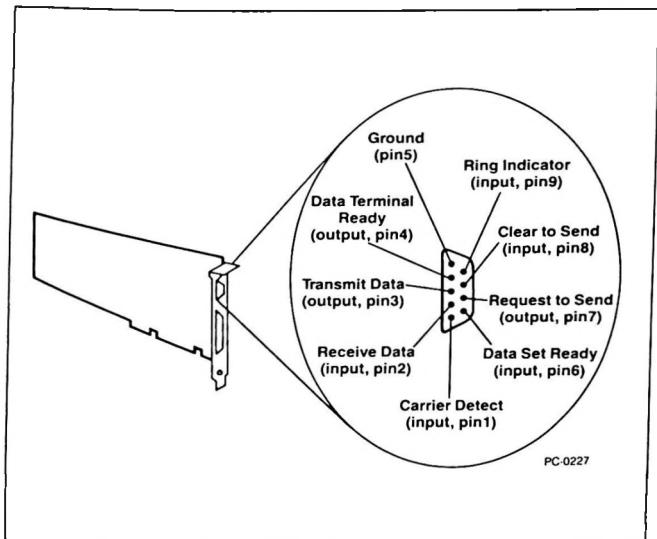
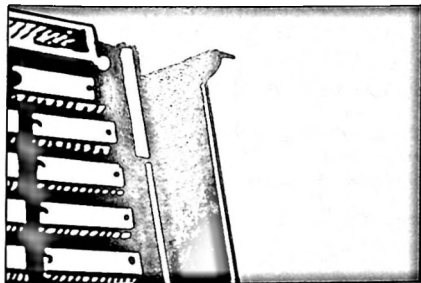


Figure 15-2 *Signals on the Above™ Board Plus 8 I/O's serial port connector*

# Putting A Chip In A Socket



Appendix A

A



## PUTTING A CHIP IN A SOCKET

This appendix explains how to insert a chip into a socket. If you've successfully put chips in sockets before, you can skip this appendix.

▼ **CAUTION** *Unless you follow step 1, you can ruin your chips.*

- 1 Before touching any chips, remove the static electricity from your hands by touching the back or side panel of your computer. See Figure A-1.

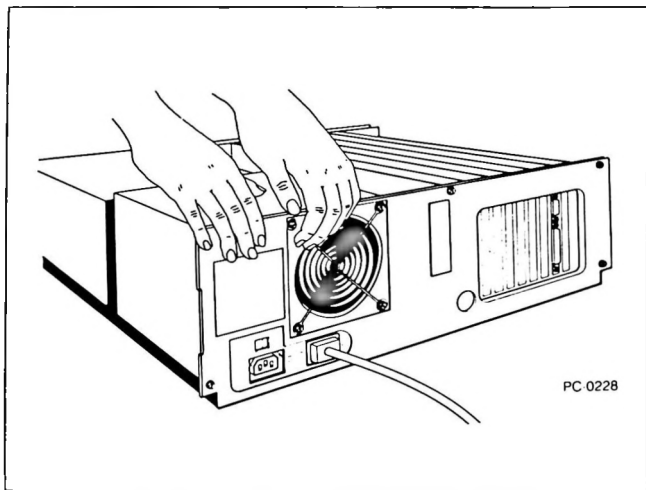


Figure A-1 *Removing static electricity from your hands*

- 2 Orient your board as shown in Figure A-2, with the metal retaining bracket on the right. Before you put a chip in a socket, make sure the notched edge of the chip points to the left. If the chip has a dot instead of a notch, make sure the edge with the dot faces left.

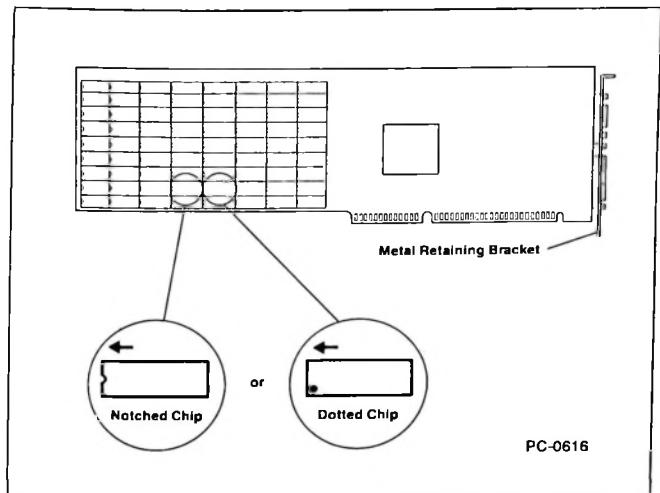
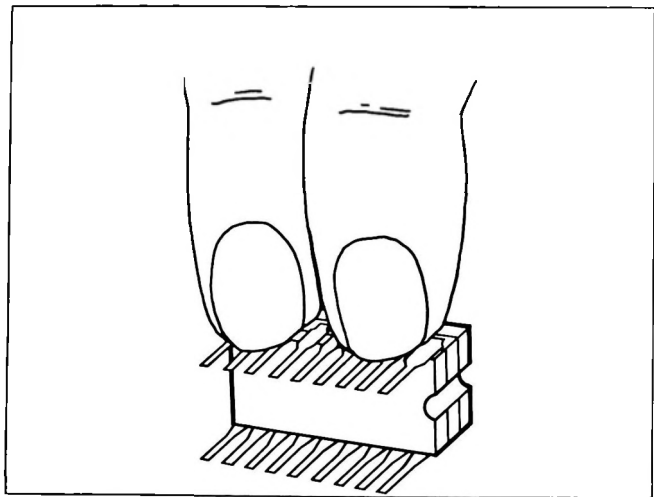


Figure A-2 *Orienting the chip correctly*

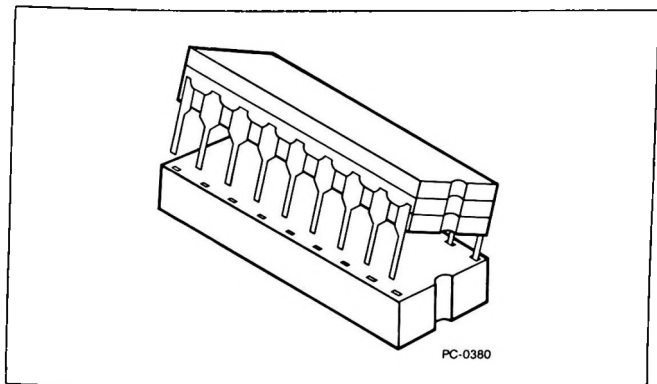
- 
- 3** Before you install the chip, verify that its pins match the holes in the socket. If they don't, align the pins by laying the chip on its side on a table (or other flat surface) and *gently* press the top edge of the chip (not the pins) as shown in Figure A-3. Repeat for the other row of pins.



**Figure A-3**     *Aligning the chip's pins*

PC-0379

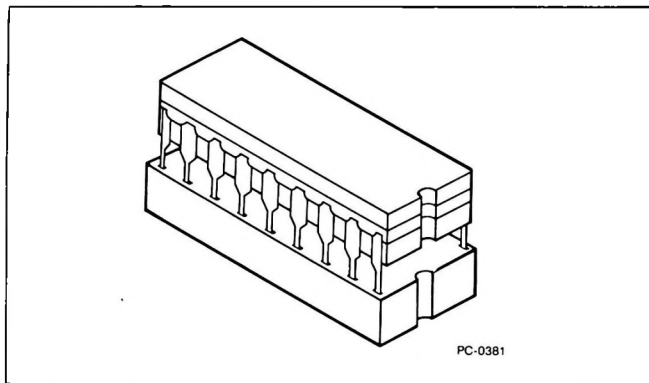
- Carefully insert the pins on one side of the chip halfway into the holes on the same side of the socket. See Figure A-4.



**Figure A-4** *Inserting pins halfway in one side of the socket*

- 5** Insert the pins from the other side of the chip halfway into the holes on that side of the socket. See Figure A-5.

If the pins don't line up with the holes, remove the chip from the socket, gently straighten the pins, and go back to step 2.



**Figure A-5** *Inserting the remaining pins halfway in the socket*

- 6 Carefully examine the chip's pins. Look for any pins that are bent under or out. (See Figure A-6.) If you find bent pins, remove the chip, gently straighten them, and go back to step 2.

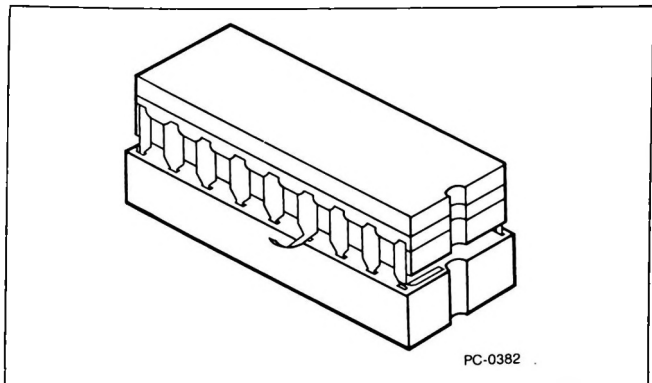


Figure A-6 *Bent pins*

- 7 When all pins are in the socket holes, apply gentle, even pressure with two fingers until the chip settles into the socket. Then apply firm pressure with both fingers until the chip will go no farther. See Figure A-7.

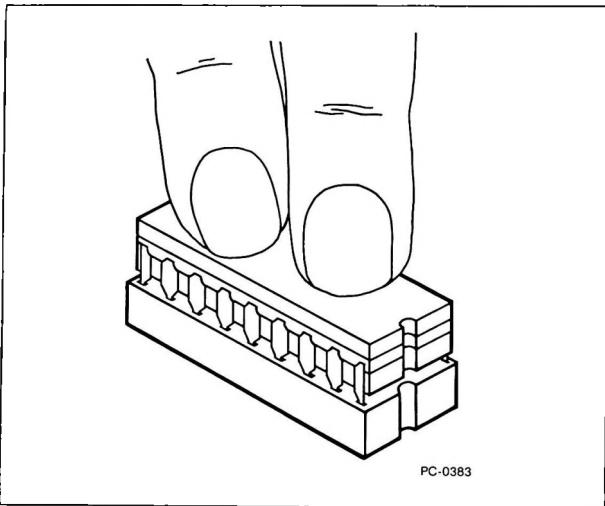
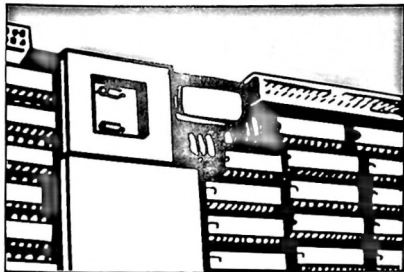


Figure A-7 *Pressing the chip into the socket*

# Troubleshooting



Appendix B

B



---

## TROUBLESHOOTING

This appendix lists the most common situations that can cause your Above Board to operate incorrectly. Read through the list of symptoms listed in this chapter. When you find one that resembles the problem you're having, try the corresponding possible solutions.

### *The computer won't print*

Possible solutions:

- Print to a different port (LPT2 instead of LPT1, or COM2 instead of COM1).
- The printer cable is not connected, or the printer is not turned on or on-line. Check the printer cable to ensure both ends are securely connected.
- Run SETBOARD to verify the ports are set up correctly.

### *SETBOARD cannot find your Above Board*

Possible solution:

- Your Above Board's base I/O address may conflict with the base I/O address of another board in your computer. Remove all the boards in your computer that you don't need, and rerun SETBOARD. Install your other boards after you've established the Above Board's correct base I/O address.

### *Above Board memory is not recognized.*

Possible solutions:

- Check the memory chips on the Above Board for correct installation (notch or dot facing the right way).
- Make sure the chips are pushed all the way in and there are no bent pins.

- 
- Make sure an even number of memory columns have chips.
  - Make sure that the memory chips on the board are on the approved list, shown in Table 4-1, in Chapter 4.
  - Run SETBOARD to verify the memory is set up correctly, and that you have set the board up for the operating speed of your computer.
  - Run TESTAB. It pinpoints non-functioning chips. If any are defective, replace them.

*You get a memory size error*

Possible solutions:

- If you have an IBM AT or compatible computer and used SETBOARD to add conventional or extended memory, a memory size error is normal. You'll correct the error when you run the computer's setup program (described in Chapter 8).
- Rerun the computer's setup program and reset memory amounts. Make sure the base memory amount equals the total amount of conventional memory, and the expansion memory amount equals the total amount of extended memory.
- If you have an IBM PC or compatible, and you used the Above Board to add conventional memory, check the switches on the computer's system board to make certain they were set correctly.

*Missing memory*

Possible solutions:

- Run TESTAB. It pinpoints non-functioning chips. If any are defective, replace them.
- Run SETBOARD. Make sure the memory setup is correct.
- Check to see that memory was added to the Above Board in pairs of columns.

- 
- Turn your computer off, wait a few moments, then turn it back on.

*When you run TESTAB, every other row of chips is reported defective*

Possible solution:

- Remove the emulation or Local Area Network card and rerun TESTAB.

*You receive a parity check error*

Possible solutions:

- Make sure the memory chips are in the "verified memory chips" table in Chapter 4.
- Run TESTAB. It pinpoints non-functioning chips. If any are defective, replace them.
- Remove the ND parameter (if present) from the "DEVICE=EMM.SYS" line in your CONFIG.SYS file. Refer to Appendix F for instructions.
- If another board was added after the Above Board, rerun SETBOARD and SOFTSET.
- Move the Above Board to different slot. Move other boards if necessary.

*You experience print buffer problems*

Possible solutions:

- Put the QUICKBUF command last in the AUTOEXEC.BAT file.
- Make sure no other print buffer is being used. If two are being used, remove one.
- If you're using a serial printer, you may need to add a MODE command to your AUTOEXEC.BAT file.

---

Possible solutions:

- Check the power cord connections.
- Check the board installation. Make sure the Above Board is seated firmly in the expansion slot.
- If you have an IBM AT or compatible computer, make certain you did not install the PC selection plug.

If you couldn't get your Above Board to work with the help of this troubleshooting section, call Intel Customer Support at the numbers listed in the next section.

## Customer support information

If you still have questions about the Above Board, please contact the Intel Customer Support department. There are several ways to get in touch with Customer Support.

The fastest way is to use FaxBack, fax, MCI Mail, CompuServe, or the Electronic Bulletin Board. These services let you send your questions and comments electronically at any time.

If you send your comments electronically, be sure to include the following information:

- Name
- Phone number of your fax machine
- Phone number where you can be reached
- A description of your computer hardware and software
- Copies of your CONFIG.SYS and AUTOEXEC.BAT files
- A description of your problem

---

### **Call the FaxBack Information Service**

If you have a fax machine or Intel Connection CoProcessor, you can call the FaxBack order line to receive up-to-date product and technical information instantly. You can reach the Intel FaxBack order line 24 hours a day by calling:

(503) 629-7576

You must use a touch-tone phone to order FaxBack information.

### **Send comments by fax machine**

- (800) 458-6231 in the United States excluding Oregon
- (503) 629-7580 in Oregon and outside the United States

### **Use MCI Mail or CompuServe**

- Send MCI mail to INTEL SUPPORT
- Use CompuServe mailbox 70307,461; forum GO INTEL

### **Call the Intel bulletin board service**

If you have a modem, you can use the Intel Electronic Bulletin Board to get up-to-date information on Intel products and leave questions for Customer Support technicians. Before you call, set your modem for 300, 1200, or 2400 bits per second; 8 data bits; no parity; and 1 stop bit.

(503) 645-6275

---

### **Call Customer Support directly**

Customer Support representatives are ready to answer your call Monday through Friday, from 7:00 AM to 5:00 PM Pacific time.

You can help the Customer Support representative serve you better if you have this manual handy and are at your computer when you call.

- (800) 538-3373 in the United States or Canada
- (503) 629-7354 outside the United States and Canada

At other times, you can leave a message and a Customer Support representative will return your call. You can also access a recorded question and answer program that provides answers to common questions.

---

### **The Intel bulletin board service**

If you have a modem, you can use the Intel Electronic Bulletin Board to get up-to-date information on Intel products and leave questions for Customer Support technicians. The Bulletin Board also has the latest versions of Intel software that you can download using the XMODEM transfer protocol.

You can reach the Bulletin Board 24 hours a day by calling:

(503) 645-6275

Before you call, set your modem for 300, 1200, or 2400 bits per second; 8 data bits; no parity; and 1 stop bit.

### **Calling Customer Support directly**

If you have a problem that requires immediate attention, you can talk to a Customer Support technician by calling one of the following numbers.

- If you are in the United States or Canada, call

(800) 538-3373

- If you are outside the United States or Canada, call

(503) 629-7354

Customer Support representatives are ready to answer your call Monday through Friday, from 7:00 AM to 5:00 PM Pacific time.

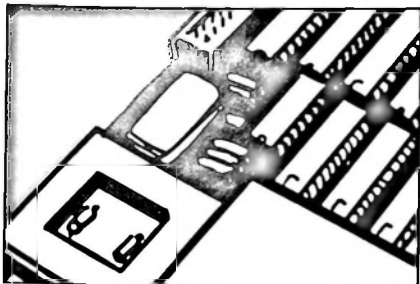
You can help the Customer Support representative serve you better if you have this manual handy and are at your computer when you call.

---

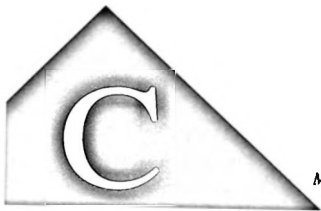
At other times, you can leave a message and a Customer Support representative will return your call. You can also access a recorded question and answer program that provides answers to common questions.



# Multiple Above™ Boards In One Computer



Appendix C



---

## MULTIPLE ABOVE™ BOARDS IN ONE COMPUTER

If you want to use the Above Board Plus 8 or Plus 8 I/O in a computer that already has an Above Board, read this appendix for advice on setting up the boards.

This appendix is divided into three parts: the first provides help for users of IBM AT and compatible computers, including the IBM PS/2 Model 30 286; the second for users of IBM PC, XT, and compatible computers, including the IBM PS/2 Model 30. For installation, read one of the first two sections that corresponds to your type of computer.

The third part of this appendix is the Hardware Worksheet for multiple Above Boards. You need to complete the information on this worksheet if you have more than one Above Board in your computer. Answering the questions on the Hardware Worksheet ensures all the important information about your Above Board is easy to find when you need it (for example, when you run the TESTAB program in Chapter 9).

▼ **NOTE** *If you're installing more than one Above Board Plus 8, Plus 8 I/O, Plus, Plus I/O, 286, or PS/286 in the same computer, you must insert them in your computer one at a time and run SETBOARD after each insertion, as described in Chapter 7.*

### For IBM AT and compatible computers

In an IBM AT or compatible computer, all of the following Above Boards can operate together:

- Above Board Plus 8
- Above Board Plus 8 I/O
- Above Board Plus

- 
- Above Board Plus I/O
  - Above Board 286
  - Above Board PS/286
  - Above Board/AT
  - Above Board PS/AT

▼ **NOTE** *Only the Above Board Plus 8 and Plus 8 I/O, Above Board Plus, Plus I/O, Above Board 286, and PS/286 will fit in the IBM XT 286 computer with its cover on. The Above Board/AT and Above Board PS/AT will run in the IBM XT 286 computer, but you won't be able to get its original cover back on.*

You can combine any of these Above Boards as long as you follow the guidelines presented in the next few sections.

### **Providing conventional memory**

Both the Above Board/AT and Above Board PS/AT can supply conventional memory from 512K to 640K. If your computer already has 512K bytes of conventional memory, either of these boards can fill out conventional memory to 640K bytes.

The Above Board Plus 8, Plus 8 I/O, Plus, Plus I/O, 286, and PS/286 can supply conventional memory in one of the following ranges:

- 256K to 640K
- 256K to 512K
- 512K to 640K

---

If you have more than one Above Board in your system, you should set up only one of them to provide conventional memory not provided by your system board.

### Providing expanded memory

You can provide up to 32M bytes of expanded memory with Above Boards in your computer. The number of boards you use is limited only by the 32M-byte memory limit and your computer's power supply.

▼ **NOTE** *You can use expanded memory with DOS versions 3.0 and greater. You can't use expanded memory with XENIX or OS/2.*

---

Table C-1 shows how much memory each Above Board and Piggyback Option could supply if all banks on each board were full.

**Table C-1**      *Maximum possible memory on Above™ Boards and Piggyback Options*

<b>Board</b>	<b>Maximum possible memory</b>
Above Board Plus 8	8M bytes
Above Board Plus 8 I/O	8M bytes
Above Board Plus	2M bytes
Above Board Plus I/O	2M bytes
Above Board 286	2M bytes
Above Board PS/286	2M bytes
Above Board AT	2M bytes
Above Board PS/AT	1.5M bytes
2MB Piggyback Option*	2M bytes
6MB Piggyback Option**	6M bytes

\*2MB Piggyback Options can be connected to an Above Board Plus, Plus I/O, 286, PS/286, AT, or PS/AT.

\*\*6MB Piggyback Options can be connected to an Above Board Plus 8, Plus 8 I/O, Plus, Plus I/O, 286, or PS/286.

### **Providing extended memory**

You can provide up to 15M bytes of extended memory with Above Boards in your computer. Table C-1 in the last section shows how much memory could be supplied by each Above Board and Piggyback Option. Extended memory can be supplied by any combination of these boards.

---

If you have an Above Board/AT with a serial number beginning with "B," your computer can only have up to 6.5M bytes of extended memory.

### **Using parallel ports**

Your computer can have up to three parallel ports (LPT1, LPT2, and LPT3), provided LPT1 is on the IBM Monochrome Display Adapter or some other manufacturer's equivalent. Otherwise, DOS limits your computer to two parallel ports.

The Above Board Plus 8 I/O, PS/286, and Above Board PS/AT can each supply one parallel port.

If your computer already has all the parallel ports it can support, disable the parallel port on your Above Board(s). Read Chapter 14 for more information about the parallel port.

### **Using serial ports**

Your computer can have up to two serial ports, COM1 and COM2.

The Above Board Plus I/O and the Above Board PS/286 can each supply up to two serial ports, and the Above Board Plus 8 I/O and Above Board PS/AT can supply one.

If your computer already has all the serial ports it can support, disable the serial port on your Above Boards. Read Chapter 15 for more information about the serial port.

---

## **For IBM PC, XT, and compatible computers**

In IBM PC, XT, and compatible computers, all of the following Above Boards can operate together:

- Above Board Plus 8
- Above Board Plus 8 I/O
- Above Board Plus
- Above Board Plus I/O
- Above Board 286
- Above Board PS/286
- Above Board PS/PC
- Above Board/PC

You can combine any of these Above Boards as long as you follow the guidelines presented in the next few sections.

### **Providing conventional memory**

You can set up only one Above Board to provide conventional memory. How you set it up depends on the boards in your system and on your memory needs.

The Above Board Plus 8, Plus 8 I/O, Plus, Plus I/O, 286, and PS/286 can supply conventional memory in one of the following ranges:

256K to 640K

256K to 512K

512K to 640K

---

The Above Board/PC can supply up to 384K of conventional memory. This additional memory, which must be contiguous, can start on any 64K-boundary between 256K and 640K.

The Above Board PS/PC can supply either 384K or 128K bytes of conventional memory, and can start at either 256K or 512K.

If you have multiple Above Boards in your system, you should configure only one of them to provide conventional memory not provided by your system board.

### **Providing expanded memory**

You can have up to 32M bytes of expanded memory in your computer. The number of boards you use is limited by the 32M-byte memory limit and your computer's power supply.

- ▼ **NOTE** *You can use expanded memory with DOS versions 3.0 and greater. You can't use expanded memory with XENIX or OS/2.*



Table C-2 shows how much memory each Above Board and Piggyback Option could supply if all banks on each board were full.

**Table C-2**      *Maximum possible memory on Above™ Boards and Piggyback Option*

Board	Maximum possible memory
Above Board Plus 8	8M bytes
Above Board Plus 8 I/O	8M bytes
Above Board Plus	2M bytes
Above Board Plus I/O	2M bytes
Above Board 286	2M bytes
Above Board PS/286	2M bytes
Above Board PC	2M bytes
Above Board PS/PC	1.5M bytes
2MB Piggyback Option*	2M bytes
6MB Piggyback Option**	6M bytes

\*2MB Piggyback Options can be connected to an Above Board Plus, Plus I/O, 286, or PS/286.

\*\*6MB Piggyback Options can be connected only to an Above Board Plus 8, Plus 8 I/O, Plus, Plus I/O, 286, or PS/286.

### Using parallel ports

Your computer can have up to three parallel ports (LPT1, LPT2, and LPT3), provided LPT1 is on the IBM Monochrome Display Adapter or some other manufacturer's equivalent. Otherwise, DOS limits your computer to two parallel ports.

---

The Above Board Plus 8 I/O, Above Board Plus I/O, Above Board PS/286, and Above Board PS/PC can each supply one parallel port.

If your computer already has all the parallel ports it can support, disable the parallel port on your Above Board(s). Read Chapter 14 for more information about the parallel port.

### Using serial ports

Your computer can have up to two serial ports, COM1 and COM2.

The Above Board Plus I/O and Above Board PS/286 can supply up to two serial ports, and the Above Board Plus 8 I/O and Above Board PS/PC can supply one.

If your computer already has all the serial ports it can support, disable the serial port on your Above Boards. Read Chapter 15 for more information about the serial port.

### Filling out the Hardware Worksheet

Before installing this Above Board, fill in the first three columns of the worksheet for the Above Boards you've already installed.

For Above Board Plus 8s, Plus 8 I/Os, Pluses, Plus I/Os, 286s, and PS/286s, record the following:

- serial number (on the Above Board and listed in SETBOARD)
- number of memory columns filled
- type of RAM chip you are using

---

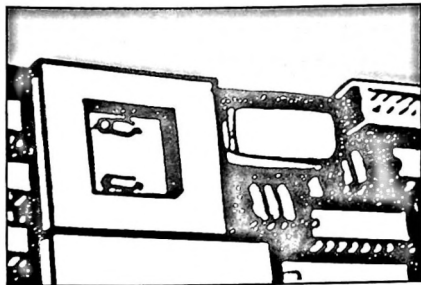
For Above PCs, PS/PCs, ATs, and PS/ATs in your computer, record the following:

- switch settings (the board's manual explains what each switch does)
- number of memory columns filled
- type of RAM chip you are using

Run SETBOARD for each Above Board installed in your computer. You can complete the information on the worksheet with the help of the summary screen at the end of SETBOARD.



# Technical Information



Appendix D



---

## **TECHNICAL INFORMATION**

This appendix contains technical information about the Above Board's software and hardware.

### **Above™ Board software**

This section describes some specific topics regarding the Above Board's software.

#### **How does expanded memory work?**

This section describes how expanded memory works. You don't need this information to set up or use expanded memory. It's provided for your information. If you're not curious about how expanded memory works, skip this section.

Even the maximum amount (640K bytes) of conventional memory is sometimes not enough for large application programs. Expanded memory lets you use large programs by accessing memory beyond 640K -- memory that DOS can't reach.

Expanded memory is divided into 16K-byte segments called pages. Your computer accesses these pages through a window that is at least 64K bytes of memory. This window is called the page frame. There are eight possible 16K pages available in the expanded memory range in IBM AT and compatible computers, allowing a maximum page frame size of 128K bytes. There are ten possible 16K pages in IBM PC, XT, and compatible computers, allowing a maximum page frame size of 160K.

---

These pages are located between 768K and 896K in IBM AT, IBM PS/2 Model 30 286, and compatible computers. The pages are located between 800K and 960K in IBM PC, XT, IBM PS/2 Model 30, and compatible computers.

Just as your computer screen can be a window into a large spreadsheet, so the page frame is a window into expanded memory.

If you are using only the Above Board Plus 8, Plus 8 I/O, Above Board Plus, or Plus I/O to supply expanded memory, the page frame can be larger than 64K bytes in increments of 16K bytes for application programs written to take advantage of version 4.0 of the *Lotus/Intel/Microsoft Expanded Memory Specification*. If you are using a mixture of Above Board types other than the Above Board Plus or Plus 8, the page frame is limited to 64K bytes.

Figure D-1 shows an IBM AT, Model 30 286, or compatible computer's conventional, expanded, and extended memory. Figure D-2 shows the memory for IBM PC, XT, Model 30, or compatible computers. (The numbers in parentheses are the hexadecimal segment addresses.)

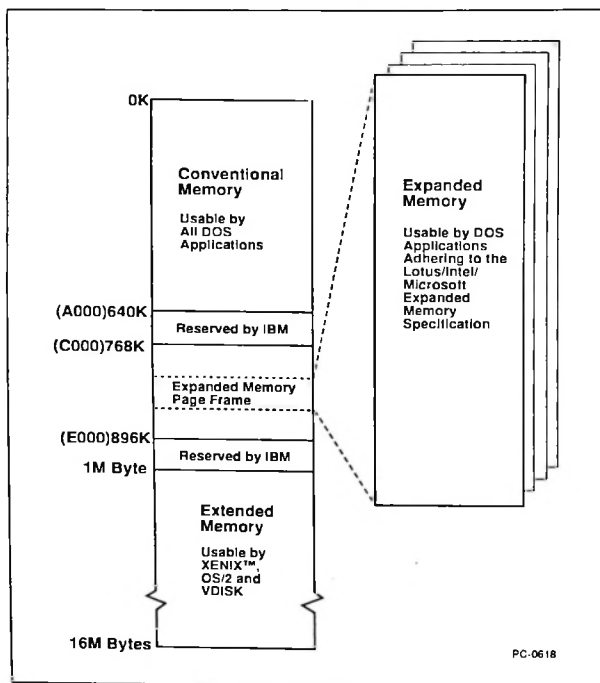


Figure D-1 Above™ Board memory for IBM AT and compatible computers



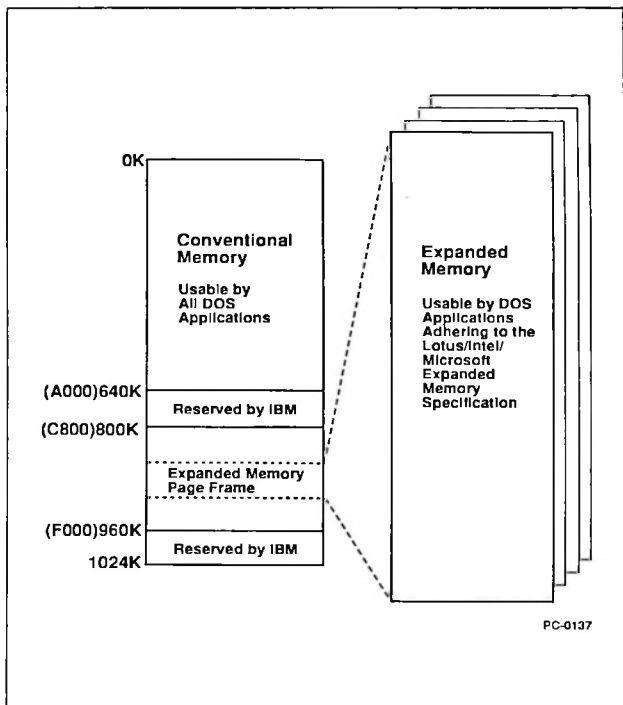


Figure D-2 Above™ Board memory for IBM PC, XT, and compatible computers

---

DOS can't manage expanded memory because the page frame is located beyond 640K. So Intel provides you with the Expanded Memory Manager (EMM). EMM manages expanded memory just as DOS manages conventional memory. EMM controls which pages of expanded memory appear in the page frame at one time. It also keeps track of which programs own which pages of expanded memory. You must have DOS version 3.0 or higher to use EMM.

### Software interrupts

The possible software interrupts used by EMM and the print buffer when the Above Board is installed are shown below.

<u>Software</u>	<u>Interrupt</u>
EMM	67
Print Buffer	8*
Pop-up Menu	5*
Serial Buffer	14*
Parallel Buffer	17*

\*Interrupts used if Quikbuf2 is installed.

### Direct Memory Access (DMA) channel

The Above Board does not support DMA transfers.

### For software developers

If you're a software developer interested in learning how to create programs that use expanded memory, contact Customer Support (the number is in Appendix B) and ask for a copy of the *Lotus/Intel/Microsoft Expanded Memory Specification*.

---

## **Above™ Board hardware**

This section describes specific topics regarding the Above Board's hardware.

### **Power supply**

If you have a compatible computer rather than an IBM AT, or an IBM PC, your power supply may not provide enough power for all the hardware options you want.

The IBM AT computer's power supply provides 20 amps of +5 volts. The system board, disk drive adapter, and disk drives consume some of this, as do the 80287 math coprocessor and each board plugged into an expansion slot.

The IBM AT computer's 20-amp power supply is sufficient to support all the boards you can put in it. But, if you have a compatible, your computer's power supply may be rated at a lower value than the IBM AT computer's.

The PC's +5-volt power supply provides about 7 amps. The system board, disk drive adapter, and disk drives consume some of this, as do the 8087 math coprocessor and each board plugged into an expansion slot. The power supply in an IBM portable, a COMPAQ portable, or any other compatible may provide even less power than the PC-1's or PC-2's.

If you plug in options that require (altogether) more power than your power supply generates, the power supply may shut itself off to prevent damage to the computer. If your power supply shuts off, the data in your memory is lost.

---

Intel suggests you have your dealer calculate the power requirements of all the options in your computer. If these options require more power than your computer's power supply can provide, you have several choices:

- Remove some of the options.
- Have your dealer install a more robust power supply.
- Buy an expansion unit, and move some of the options from your system unit to the expansion unit.

Although some users take a chance on their computer's power supply, Intel recommends a more conservative approach. Before you install your Above Board (or any other board from any manufacturer), ask your dealer whether you're overloading your power supply.

### **Power consumption**

Each Above Board (without a Piggyback Option) consumes *no more than* 2.0 amps at +5.0 volts. This assumes that the board is fully populated with 1M-bit chips. Refer to the above section for more information about your computer's power supply.

---

## Hardware Interrupts

The possible interrupts used by the parallel and serial ports when the Above Board is installed are shown below.

<u>Serial Port</u>	<u>I/O</u>	<u>Interrupt</u>
COM1	3F8-3FFH	4
COM2	2F8-2FFH	3
COM3	3E8-3EFH	2
COM4	2E8-2EFH	5

<u>Parallel Port</u>	<u>I/O</u>	<u>Interrupt</u>
LPT1	378-37F	5
LPT2	278-27F	7

The I/O addresses and interrupts for the serial and parallel ports are assigned when you run SETBOARD. The interrupts for the parallel ports cannot be changed.

- ▼ **NOTE** *Your computer can have up to three parallel ports only if LPT1 is on the IBM Monochrome Display Adapter (I/O address 3BC). Otherwise your computer is limited to two parallel ports.*

---

### **Above Board's base I/O address**

The Above Board's base I/O address is assigned when you run the SETBOARD program. If you run Manual Setup, you can set the I/O base address yourself. Remember, you must assign a unique I/O address to each Above Board in your computer. Above Boards cannot share I/O addresses.

#### I/O Address

208

218

248

258

2A8

2B8

2E8

### **Number of slots**

An Above Board without the Piggyback Option fits in one expansion slot.

An Above Board combined with the Piggyback Option requires one-and-a-half slots. The Piggyback Option occupies only half of the second slot. You can put another short board (for example, the IBM AT Serial/Parallel Adapter) in the same slot. If you have a Piggyback Option, refer to *The Installation Guide* for the Above Board 6MB Piggyback Option for more information about installing the 6MB Piggyback Option.

### **Memory capacity**

Each Above Board Plus 8 can provide your computer with as much as 8M bytes of memory. When the 6MB Piggyback Option is attached, the combination can provide as much as 14M bytes.

---

### **Acceptable memory chips**

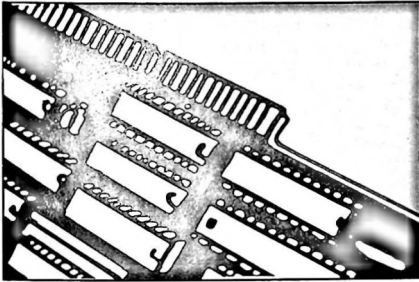
Intel has verified that the chips listed in Table 4-1 (in Chapter 4) work correctly with the Above Board. Others may work, but they haven't been verified.

You *cannot* use 64K- or 256K-bit chips on the Above Board Plus 8 and Plus 8 I/O.

### **Maximum number of boards per computer**

You can have up to 32M bytes of expanded memory, and 15M bytes of extended memory in your computer. The number of boards you use is limited by the 32M-byte expanded memory limit, the 15M byte extended memory limit, the number of slots in your computer, and your computer's power supply (see page D-7).

# Mapping Conventional Memory



Appendix E

E



---

## MAPPING CONVENTIONAL MEMORY

Version 4.0 of the *Lotus/Intel/Microsoft Expanded Memory Specification* defines functions that enable operating systems or operating environments such as Windows 2.0 or DESQview to map conventional memory in the same way expanded memory is mapped. When you use programs that take advantage of mappable conventional memory, you can load more background applications (word processing, spreadsheets, etc.) and swap between the applications faster.

- ▼ NOTE *Your system must contain only Above Board Plus 8s, Plus 8 I/Os, Pluses, or Plus I/Os to take advantage of mappable conventional memory.*

### How mappable conventional memory is used

Mappable conventional memory means that a given area of the conventional memory supplied by the Above Board can be used in the same way that the page frame of expanded memory is used.

- ▼ NOTE *The Above Board can only supply conventional memory between 256K and 640K -- your computer must supply the first 256K. This is the area where DOS and system software must reside.*

Mappable conventional memory is used only by operating systems and operating environments. It is never used by ordinary application programs. Figure E-1 shows mappable conventional memory from 256K to 640K bytes.

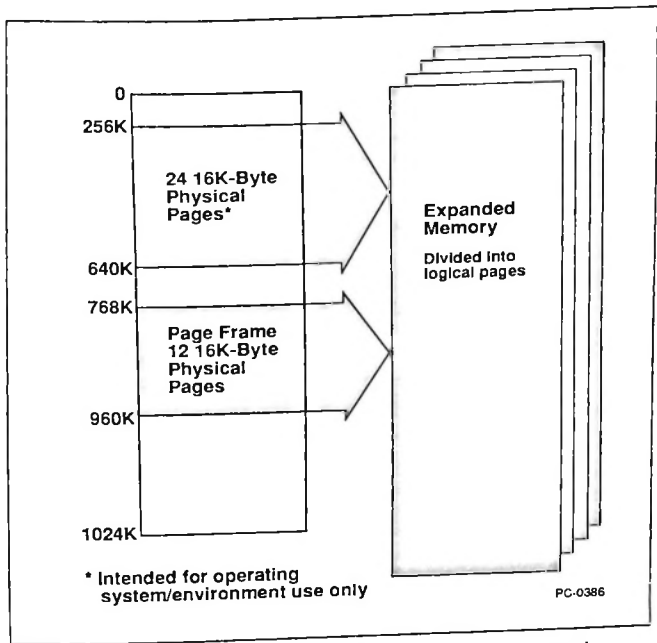


Figure E-1 *Above™ Board expanded and mappable conventional memory for IBM PC, XT, and compatible computers*

---

## How to provide mappable conventional memory

To have your Above Board supply mappable conventional memory, it must first supply conventional memory. To set up your Above Board to supply conventional memory, follow the installation steps below:

- 1** Add memory to the Above Board (Chapter 4). This is optional.
- 2** Fill out the Hardware Worksheet (Chapter 5).
- 3** Install the Above Board (Chapter 6).
- 4** Because only the Above Board's conventional memory can be made mappable, you may want to disable conventional memory on your computer so the Above Board can supply more. Refer to your computer's *Installation Manual*, *Operations Guide*, or similar manual for instructions. If you have an Above Board other than the Plus 8, Plus 8 I/O, Plus, or Plus I/O supplying conventional memory, disable conventional memory on the other board first.

An example illustrating disabling conventional memory on an IBM AT is included later in this chapter.

- 
- 5 Run the SETBOARD program (Chapter 7). The SETBOARD installation program lets you fill in conventional memory that is not supplied by your computer with Above Board Plus 8 or Plus 8 I/O memory. (If you have an IBM PC or compatible computer, and the Above Board is supplying some of the conventional memory, you may need to change the switches on the computer's motherboard as described in Chapter 7.)

▼ **NOTE** *If you have multiple Above Boards in your computer, you must set only one of them to supply conventional memory when you run SETBOARD. Never assign the same conventional memory range to two Above Boards.*

- 6 Run your computer's setup program, if necessary (Chapter 8).
- 7 Run the SOFTSET program and select the mappable conventional memory option.

▼ **NOTE** *If you have a Model 30 286 or other computer that recognizes 639K bytes instead of 640K bytes of conventional memory, and you want the Above Board to supply mappable conventional memory, you must add the MCL=9800 parameter to the DEVICE=EMM.SYS command line in your CONFIG.SYS file. Appendix F explains how.*

Remember, the Above Board can only provide conventional memory in one of the following ranges:

- 256K - 640K bytes
- 256K - 512K bytes
- 512K - 640K bytes

---

### **How to disable computer memory to provide more mappable conventional memory**

Some computers have system boards that provide 640K or 512K of conventional memory, leaving either no memory or only 128K that could be assigned as mappable conventional memory. If you would like more conventional memory defined as mappable, you must disable some of the conventional memory supplied by your system board, if it is possible to do so in your computer.

**Example.** You have an 8 MHz IBM AT or compatible that has a system board that provides 640K of conventional memory. Since you use applications that take advantage of mappable conventional memory, you want to disable the memory on your system board down to 256K bytes. To do this, remove the cover and any boards that are in the way. Refer to the instructions in the computer's installation manual if you don't know how to do this.

Next, find jumper J18, as shown in Figure E-2. Notice that the jumper encloses the two pins closest to the front of the computer.

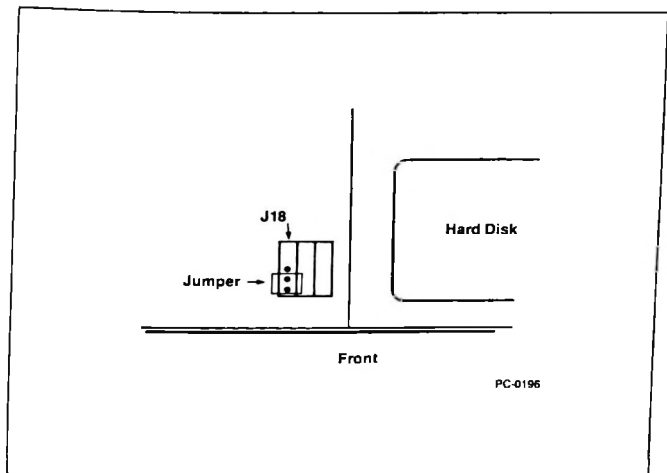
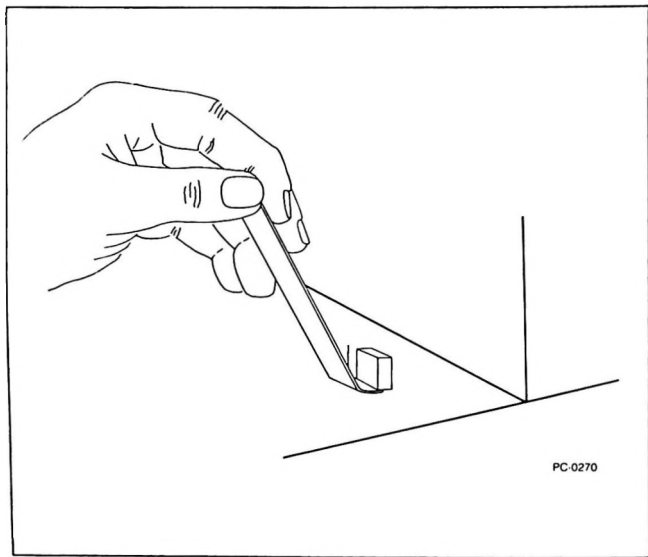


Figure E-2 *Jumper J18 on the computer's system board*

As shown in Figure E-3, remove the jumper, taking care not to damage it.



**Figure E-3**     *Lifting jumper J18*

Move the jumper one pin over. The jumper should now enclose the two pins farthest from the front panel, as shown in Figure E-4.

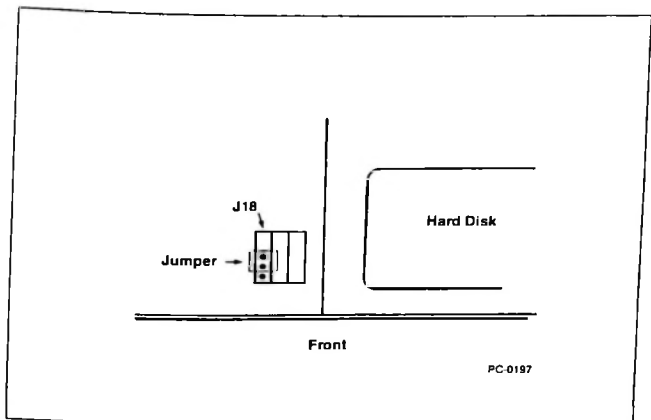


Figure E-4 *New position for jumper J18*

The system board in your IBM AT or compatible computer now supplies conventional memory from 0 to 256K. You need to have the Above Board provide memory from 256K to 640K, so you run SETBOARD. You may have to run your computer's setup program again, if you get a memory configuration error when you restart your computer after running SETBOARD.



# Manually Installing the Above Board Software



Appendix F



---

## INTRODUCTION

This appendix gives you the information you need to manually add the necessary Above Board Plus 8 and Plus 8 I/O command lines to your CONFIG.SYS file. It helps you understand and use the Above Board Plus 8 software with less reading.

But be forewarned -- this appendix is for DOS experts. If you get confused, turn to the appropriate chapter in the manual.

- ▼ **NOTE** *This appendix assumes you know the differences between conventional, extended, and expanded memory. If you don't, refer to Chapter 2 for definitions.*

## MANUALLY INSTALLING THE ABOVE™ BOARD SOFTWARE

The Above Board comes with software that lets you:

- use expanded memory
- use the conventional memory supplied by the Above Board as mappable conventional memory
- create RAM disks
- create a print buffer

If you boot from floppy diskettes, install the Above Board software on each system diskette from which you boot. If you boot from a hard disk, install the software just once in the root directory.

---

Installing the software manually involves these steps:

- Copying files (page F-3)
- Setting up expanded memory (page F-4)
- Setting up RAM disks (page F-21)
- Setting up a print buffer (page F-22)

In general, you don't have to do all this copying and setting up. The SOFTSET program, described in Chapter 10, can do it automatically. This Appendix describes the do-it-yourself technique.

## Copying files

Before you can use the Above Board software, you must copy files from the Intel diskette to your hard disk's root directory or to your system diskettes. Copy only the files you need.

If you have more than one Above Board software diskette, check the date on the diskettes, and make sure you install the most recent version of the software.

---

The Above Board software includes the following files:

<u>File Name</u>	<u>Description</u>
EMM.SYS	Activates expanded memory on Above Board Plus 8 and Plus 8 I/O only. Also allows mappable conventional memory.
QUIKMEM2.SYS	Creates a RAM disk in expanded memory.
QUIKBUF2.COM	Creates a print buffer in expanded memory.

Copy the files you need for the features you want to use.

### **Setting up expanded memory for Above™ Board Plus 8 and Plus 8 I/O boards only**

This section describes the command line you need to put into your CONFIG.SYS file if an Above Board Plus 8 or Plus 8 I/O provides the expanded memory in your computer. Use the same command line for Above Board Plus or Plus I/O.

If you will use *both* an Above Board Plus 8, Plus 8 I/O, Plus, or Plus I/O and another type of Above Board (Above Board 286, PS/286, AT, PS/AT, PC, or PS/PC) to supply expanded memory, skip this section and go to page 20 for the appropriate EMM command line.

To use expanded memory on Above Board Plus 8 and Plus 8 I/O boards, add this command as the *first* line in your CONFIG.SYS file:

DEVICE=EMM.SYS *Computer I/O\_Address 1..16*  
[EXPF=x] [EXPL=x] [ND] [NP] [NE] [VI]  
[MC] [RD] [H=x] [MCF=x] [MCL=x]

The parameters *without* brackets ([]) are required; those in brackets are optional. The order of the parameters doesn't matter.

- ▼ NOTE *The MC, RD, MCF, and MCL parameters work only with the Above Board Plus 8, Plus 8 I/O, Plus, and Plus I/O.*
- ▼ NOTE *If there is an Inboard PC installed in your system, the EMM.SYS command line must be inserted below the INBRDPC.SYS line in the CONFIG.SYS file.*

### Required EMM command line parameters

The *Computer* parameter defines the type of computer in which the Above Board is installed. Replace the *Computer* parameter with one of the choices listed here:

<u>Parameter</u>	<u>Computer Type</u>
pc (or PC)	COMPAQ DESKPRO IBM PC IBM XT IBM PC or XT compatibles
at (or AT)	COMPAQ DESKPRO 286 COMPAQ DESKPRO 386 IBM AT IBM XT 286 IBM PS/2 Model 30 286 IBM AT compatibles
mod30 (or MOD 30)	IBM PS/2 Model 30

---

The *I/O\_ Address* parameters specify which base I/O addresses Above Boards use. Assign a unique I/O address to each Above Board. No boards in your computer can share I/O addresses. Piggyback Memory boards use the I/O addresses of the Above Boards to which they are attached.

Use one *I/O\_ Address* parameter value for each Above Board Plus 8 and Plus 8 I/O in your system. Be sure your *I/O\_ Address* parameter values match the I/O addresses selected when you ran the SETBOARD program. These are displayed on the final summary screen when you run the SETBOARD program, or if you choose the VIEW option in SETBOARD.

#### I/O address

208  
218  
248  
258  
2A8  
2B8  
2E8

**Example.** You're installing two Above Board Plus 8 boards in an IBM AT. One board is set for I/O address 208, the other for address 258. Use this command:

```
DEVICE=EMM.SYS AT 208 258
```

The **EXPF=x** (expanded first) and **EXPL=x** (expanded last) parameters specify the range of addresses of the expanded memory page frame.

---

If you omit the EXPF and EXPL parameters, EMM automatically searches the address range between 768K and 960K (hexadecimal segment address C000 to F000 is checked for ROM or RAM), selecting the largest unused contiguous area in that range as the page frame. The EXPF and EXPL parameters override this automatic mapping and let you specify the range of the page frame search. This might be necessary to enable the Above Board to work with some network, communication, and video boards.

The EXPF parameter specifies the beginning of the first 16K-byte page. The EXPL parameter specifies the beginning of the last 16K-byte page. The values you use must be hexadecimal segment addresses that represent 16K-byte boundaries between 768K and 944K. The range that you specify should not overlap any RAM or ROM on other add-in boards in your computer. The possible values are:

<u>Value</u>	<u>Address</u>
C000	768K
C400	784K
C800	800K
CC00	816K
D000	832K
D400	848K
D800	864K
DC00	880K
E000	896K
E400	912K
E800	928K
EC00	944K

---

You can include either or both of the EXPF and EXPL parameters. If you include both, EMM uses both addresses you specify and searches that range for the largest unused contiguous area to use as the page frame (the minimum size is 64K). If you include just the EXPF parameter, EMM starts the page frame search at the EXPF address and selects the largest contiguous area between that address and 944K. If you include just the EXPL parameter, EMM selects the largest contiguous area it finds between 768K and the end of the 16K-byte area specified with the EXPL parameter.

If you specify addresses less than C000 or greater than DC00, if you specify a page frame that is less than 64K, or if you invert the values (that is, specify a larger value for EXPF than for EXPL), EMM displays a message and does not install.

**The MC (mappable conventional memory) parameter** causes EMM to make all conventional memory supplied by Above Board Plus 8, Plus 8 I/O, Plus, or Plus I/O boards mappable. (You can limit the mappable range by using the MCF and MCL parameters.) Mappable conventional memory enables operating environments such as Windows 2.0 and DESQview to perform conventional memory mapping. Refer to Appendix E in the manual for more information about mappable conventional memory.

If you want to use conventional memory supplied by the Above Board Plus 8 or Plus 8 I/O as mappable conventional memory (described in Appendix E of this manual), be sure you do the following:

- Make sure that you add the MC (or the MCF or MCL) parameter to the EMM command line.



- 
- The Above Board must supply the conventional memory you want to make mappable. Many computers provide 512K or 640K of conventional memory, leaving either 128K or no memory that could be assigned as mappable conventional memory. If you want more conventional memory defined as mappable, disable some of your system board memory. See your computer's operation guide for information on how to disable some of the conventional memory in your computer. Appendix E of the manual has an example.

▼ NOTE *Your computer must supply at least 256K bytes of conventional memory.*

▼ NOTE *Do not use the MC parameter if you have an Inboard 386 installed.*

The **MCF=x** (mappable conventional first) and **MCL=x** (mappable conventional last) parameters provide the same function as the MC parameter (making conventional memory supplied by Above Board Plus 8, Plus 8 I/O, Plus, and Plus I/O boards mappable), but they also let you restrict the beginning and ending addresses of mappable conventional memory. These parameters are useful only if you run an operating environment (such as Microsoft Windows 2.0) that uses version 4.0 of the Expanded Memory Specification to map conventional memory. If you include either or both of the MCF and MCL parameters, you do not need to include the MC parameter. If you don't want mappable conventional memory, you don't need to include these parameters.

---

When you include the MC parameter, EMM determines the range of the conventional memory supplied by Above Board Plus 8, Plus 8 I/O, Plus, or Plus I/O boards (this can start no lower than 256K) and this becomes the range of mappable conventional memory. If you use the MCF and MCL parameters instead of MC, you can specify the starting and ending addresses for mappable conventional memory within the address range supplied by the Above Board Plus 8, Plus 8 I/O, Plus, or Plus I/O board.

The MCF parameter specifies the beginning of the first 16K-byte area of mappable conventional memory. The MCL parameter specifies the beginning of the last 16K-byte area of mappable conventional memory. The values you use must be hexadecimal segment addresses that represent 16K-byte boundaries (starting at 256K) in the 640K-byte conventional memory area. The possible values are:

<u>Value</u>	<u>Address</u>	<u>Value</u>	<u>Address</u>
4000	256K	7000	448K
4400	272K	7400	464K
4800	288K	7800	480K
4C00	304K	7C00	496K
5000	320K	8000	512K
5400	336K	8400	528K
5800	352K	8800	544K
5C00	368K	8C00	560K
6000	384K	9000	576K
6400	400K	9400	592K
6800	416K	9800	608K
6C00	432K	9C00	624K

If you specify a value that is not a multiple of 16K, EMM rounds up the value to the next 16K increment.

---

You can include either or both of the MCF and MCL parameters. If you include both, EMM uses both addresses you specify to determine mappable conventional memory range. If you include just the MCF parameter, EMM starts mappable conventional memory at the MCF address and ends it wherever the conventional memory supplied by the Above Board ends. If you include just the MCL parameter, EMM starts mappable conventional memory wherever the conventional memory supplied by the Above Board starts, and ends mappable conventional memory at the end of the 16K-byte area specified with the MCL parameter.

If you specify addresses less than 256K or greater than 640K, or if you invert the addresses (that is, specify a larger address for MCF than for MCL), EMM displays a message and does not install.

**Example 1.** You're using an IBM PS/2 Model 30 286 that includes one Above Board Plus 8 that is set to I/O port 258. You want to provide mappable conventional memory for operating environments such as Microsoft Windows 2.0. Your Above Board is set to provide conventional memory from 256K to 640K. You want EMM to begin mapping at 256K and stop mapping at 624K (a requirement for Windows and DESQview). Use the following command:

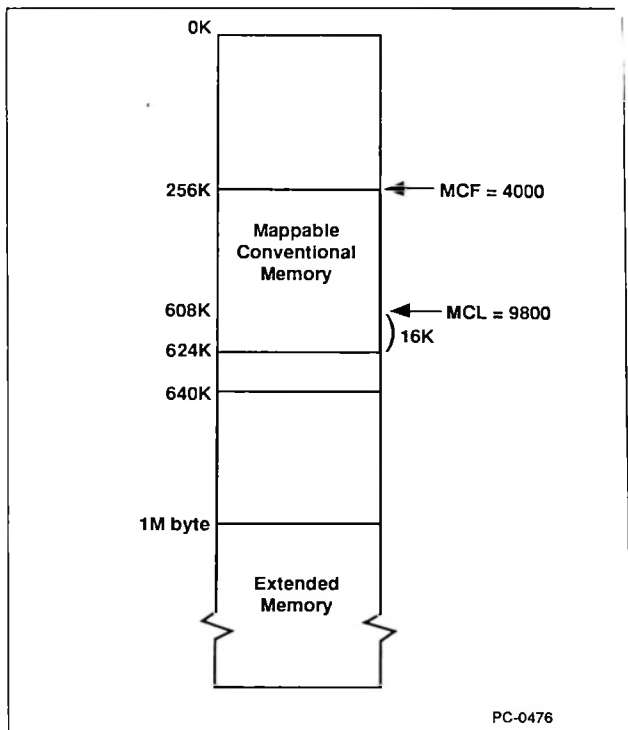
```
DEVICE=EMM.SYS AT 258 MCL=9800
```

It is not necessary here to specify the starting address, since it will automatically use 256K. Figure F-1 shows the mappable conventional memory specified with these parameters.

---

Notice that the MCL value (9800) is equivalent to 608K, not 624K. That is because the MCL value represents the start of the last 16K bytes of mappable memory. Therefore,  $608K + 16K = 624K$ , where mappable conventional memory actually ends.

Because you did not specify EXPF or EXPL, EMM will automatically search for and select an expanded memory page frame for you.



**Figure F-1** *Specifying mappable conventional memory from 256K to 624K (MCL=9800)*

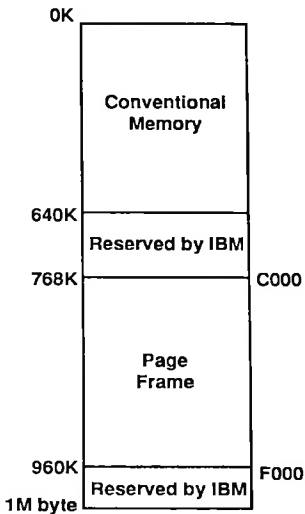
---

**Example 2.** You're using an IBM XT that includes one Above Board Plus 8 at I/O port 258. The following command assigns all of the Above Board memory as expanded memory.

```
DEVICE=EMM.SYS PC 258
```

Because you did not include the EXPF and EXPL parameters, EMM automatically uses the largest unused contiguous area between 800K and 960K as the page frame. Figure F-2 illustrates the case in which all of this area (ten 16K-byte pages) is used as the page frame.

The area selected depends on your system configuration. Other add-in boards with RAM or ROM in the address range between 800K and 960K will limit the page frame size and location. To load, EMM requires one contiguous 64K-byte block in this range.



PC-0619

**Figure F-2** *Page frame obtained by omitting the EXPF and EXPL parameters (ten 16K-byte pages) in an IBM PC or XT*

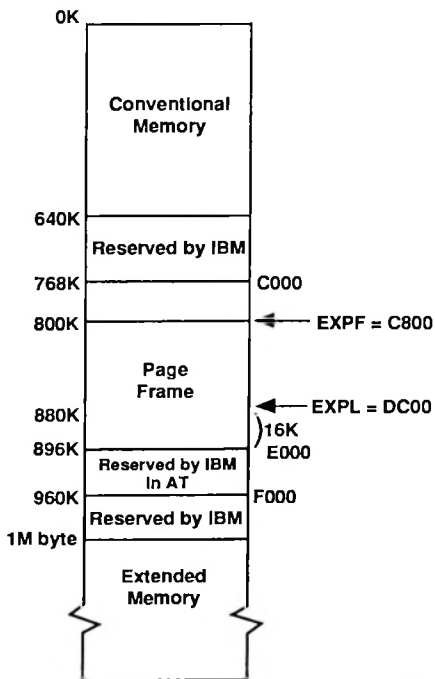
---

The **EXPF** and **EXPL** parameters let you limit the size of the page frame. The following command instructs EMM to find a page frame between 800K and 896K.

```
DEVICE=EMM.SYS PC 258 EXPF=C800  
EXPL=DC00
```

Figure F-3 illustrates the case in which all of this area (six 16K-byte pages) is used as the page frame. Notice that the EXPL value (DC00) is equivalent to 880K, not 896K. That is because the EXPL value represents the start of the last 16K-byte page of the page frame. Therefore,  $880K + 16K = 896K$ , where the page frame actually ends.





PC-0620

**Figure F-3** Page frame obtained by specifying *EXPF=C800* and *EXPL=DC00* (six 16K-byte pages)

---

The **RD** (relocate driver) parameter causes EMM to be installed in expanded memory instead of conventional memory. This conserves conventional memory. One page (16K) of expanded memory is reserved for use by EMM if you use this parameter.

If the RD parameter is absent, EMM will be loaded into conventional memory.

The **H=x** (handle count) parameter lets you tell EMM to support as many handles as a particular application program needs. A handle is a value that EMM assigns and uses to identify a block of expanded memory requested by an application program. EMM must keep track of all the handles it supports; more handles increases the size of EMM. Specifying a small EMM handle count (less than 64) can save conventional memory because it takes up less room, and allows EMM to run faster.

The EMM handle count default is 64 handles. Application programs written to use EMM versions below EMM 4.0 use a maximum of 32 handles. If you're using older application programs, you may change the EMM handle count to **H=32**, but using the default of 64 handles will work fine. The maximum value for *x* is 255 handles.

The **H=x** parameter is optional. If the **H=x** parameter is in the command line, the EMM will support the number of handles specified by *x*. The handle count will also appear on the screen when EMM is installed. If **H=x** is absent, the EMM uses 64 handles. You won't see a handle count on the screen when EMM is installed unless you specify a value for the H parameter, or have the VI parameter on the command line.

---

**Example.** You're using one Above Board Plus 8 in an IBM AT. You want expanded memory installed at D000. The board is set for I/O address 258. You want all conventional memory made mappable, EMM installed in expanded memory, and you want the default handle count of 64. Use this command:

```
DEVICE=EMM.SYS AT EXPF=D000 258 MC RD
```

**The ND (no diagnostics) parameter** tells software to run abbreviated memory tests after a warm boot (Ctrl-Alt-Del). The ND parameter is optional. If ND is in the command line, EMM will run abbreviated memory tests; if ND is absent, EMM will run full tests. In either case, full tests are run during a cold boot (power-on).

**The NP (no pause) parameter** overrides the EMM pause after an EMM error or advisory message. The NP parameter is optional. If NP is in the command line, EMM won't pause after errors or messages. If NP is absent, EMM will pause.

**The NE (no extended memory tests) parameter** tells EMM not to run extended memory tests. Use this parameter in an IBM AT or compatible computer if *no* extended memory exists on *any* Above Board on your system board.

The NE parameter is optional. If NE is in the command line, no extended memory tests are performed. If NE is absent, tests are performed. If you have any extended memory in your system, *do not* use the NE parameter.

▼ **CAUTION** *Using the NE parameter can damage the data on your hard disk if you have extended memory in your system. Do not select this option if your Above Board is supplying extended memory.*

---

The **VI parameter** lets you display all information on EMM configuration. It is optional. If it is in the command line, all EMM configuration information is displayed. If VI is absent, only information relating to the parameters you select is displayed.

## Set up when different Above Board types supply expanded memory

This section describes the command line you need to put into your CONFIG.SYS file if you are using both an Above Board Plus 8, Plus 8 I/O, Plus, Plus I/O and another type of Above Board (Above Board 286, PS/286, AT, PS/AT, PC, PS/PC) to provide expanded memory in your computer.

To use expanded memory on your boards, add this command as the *first* line in your CONFIG.SYS file using only these parameters:

```
DEVICE=EMM.SYS Computer I/O Address 1...16  
[H=x] [EXPL] [EXPF] [VI] [ND] [NE]
```

The parameters *without* brackets ([]) are required; those in brackets are optional. The order of the parameters doesn't matter.

For an explanation of the parameters, see pages 5 through 20. All the previously described parameters work except MC, MCF, MCL, and RD. These parameters work in computers that contain the Above Board Plus 8, Plus 8 I/O, Plus, or Plus I/O only.

▼ **NOTE** *If there is an Inboard 386/PC installed in your system, the EMM.SYS command line must be below the INBRDPC.SYS line in the CONFIG.SYS file.*

---

## Setting up RAM disks

You can set up Above Board RAM disks in expanded memory. This section explains how.

For *each* RAM disk you install in expanded memory, put a line like this in the CONFIG.SYS file after the EMM.SYS line:

```
DEVICE=QUIKMEM2.SYS x
```

The *x* parameter specifies the size of the RAM disk in K bytes and must be at least 16. Values that aren't multiples of 16 are rounded up to the next-higher multiple of 16. The maximum size of a RAM disk is 8M bytes (8192K).

**Example.** For two 1600K-byte RAM disks in expanded memory, put these two lines in the CONFIG.SYS file:

```
DEVICE=QUIKMEM2.SYS 1600  
DEVICE=QUIKMEM2.SYS 1600
```

DOS limits you to 26 disk drives, which includes all of the fixed and floppy disk drives and RAM disks in the system. It also assigns a unique drive letter to each disk drive. For a typical computer with a hard disk, the first RAM disk is D. For a two-floppy computer with no hard disk, the first RAM disk is C. Additional RAM disks receive sequential letters.

## Setting up a print buffer

To set up a print buffer in expanded memory each time you turn on or restart your computer, you'll need to add a command to your AUTOEXEC.BAT file. Use any ASCII file editor (such as EDLIN) to edit your file.

---

▼ **NOTE** *You can have only one print buffer. If a command in your AUTOEXEC.BAT file already sets one up, delete that command before adding the commands described in this section.*

To set up the print buffer in expanded memory, use this command:

```
QUIKBUF2 c x d t
```

The *c* parameter tells the QUIKBUF program what type of computer you're using. The choices for the *c* parameter are:

<u>Parameter</u>	<u>Computer Type</u>
at (or AT)	For IBM AT and compatible computers such as the IBM AT and XT 286, and the COMPAQ DESKPRO 286.
pc (or PC)	For IBM PC, XT, and compatible computers such as the COMPAQ Deskpro 86.
mod30 (or MOD30)	For the IBM Personal System/2 Model 30.
mod30/286 (or MOD30/286)	For the IBM Personal System/2 Model 30 286.

The *x* parameter specifies the size of the buffer in K bytes and must be 32 or greater. Any value that isn't a multiple of 16 is rounded up to the next-higher multiple of 16. 16K of the buffer is reserved for the pop-up.

The *d* parameter tells the QUIKBUF program what display adapter your computer uses.

---

Choices for the *d* parameter are

M (or m)	IBM Monochrome Adapter.
H (or h)	Hercules Monochrome Graphics Adapter.
G (or g)	IBM, Zenith, AT&T, or Hercules Color Graphics Adapter. IBM Personal System/2 Model 30 or COMPAQ monochrome or color adapter.
E (or e)	IBM Enhanced Graphics Adapter.
V (or v)	IBM Video Graphics Array. IBM Personal System/2 Model 30 286 adapter.
O (or o)	All other adapters, including the Hercules Graphics Plus Adapter. Choosing this option disables the print buffer command menu, described in Chapter 13. The print buffer will still work, but you won't be able to control it from the command menu.

The *t* parameter indicates the type of port to be buffered. Here are the choices:

P Parallel	(LPT1, LPT2, or LPT3)
S1 Serial	(COM1)
S2 Serial	(COM2)

---

If you choose P, the first thing you print or the print buffer commands you use will determine whether the buffered port is LPT1, LPT2, or LPT3. See the print buffer chapter in the manual for details. If you omit the *t* parameter, the print buffer defaults to parallel.

If you choose S1 or S2, you may need to add one or two MODE commands to your AUTOEXEC.BAT file. See the DOS manual or Chapter 15 in the Above Board manual for details.

**Example.** Suppose you have an IBM AT and an IBM Enhanced Graphics Adapter. If you want a 144K-byte print buffer in expanded memory and you want to print your data on a serial printer attached to COM1, use this command:

```
QUIKBUF2 at 160 E S1
```

This creates a print buffer of 160K bytes, but since 16K is used for the pop-up, you are left with the 144K-byte buffer you wanted.

## Using the optional programs

This section describes the optional programs available on the Above Board diskette. These programs don't need to be run; they're included for your convenience.

Here's how to start these programs:

- 1 With your screen displaying the DOS prompt, insert a copy of the Intel diskette into drive A.

- 2 Type

```
A: [command]
```



---

and press Enter. Replace the *command* parameter with the command listed in the following table for the specific program you want to run.

<u>Command</u>	<u>Program</u>
CHKMEM	Displays the amount of conventional, extended, ( <i>IBM AT and compatible computers only</i> ) and expanded memory in your computer.
TESTAB	Tests and pinpoints bad RAM chips on your Above Board.
SOFTSET	Sets up expanded memory, mappable conventional memory, RAM disks, and a print buffer.

---

# Glossary

This glossary defines some of the technical terms used in this manual. The terms are defined in alphabetical order.

## **80286-based computer**

80286-based computers are computers that use the 80286 microprocessor as their central processing unit. IBM AT and XT 286 computers are examples of the types of 80286-based computers in which the Above Board Plus 8 will work. Even if your computer contains an accelerator board, such as an Inboard 386/AT, it is still considered an 80286-based computer.

Some 80386-based computers, such as the COMPAQ 386 computer, act like compatible 286-based computers, and the Above Board will work in this kind of computer as well.

## **8088- or 8086-based computer**

8088- or 8086-based computers are computers that use the 8088 or 8086 microprocessors as their central processing unit. IBM PC and XT computers are examples of the types of 8088-based computers in which the Above Board Plus 8 will work. The COMPAQ DESKPRO 86 is an example of the type of 8086-based computer in which the Above Board Plus 8 will work. Even if your computer contains an accelerator board, it is still considered an 8088- or 8086-based computer.

---

## Above<sup>TM</sup> Board

Intel calls this board the Above Board because it lets you add usable memory *above* the limits that DOS sets (640K bytes).

By installing Above Boards you can add up to 32M bytes of expanded memory for DOS application programs and up to 15M bytes of extended memory (IBM AT and compatible computers only) for XENIX, VDISK, and OS/2. Expanded and extended memory are defined elsewhere in this glossary.

At the time this manual was written, Intel made ten types of Above Boards.

- The Above Board Plus 8 and Plus 8 I/O work in IBM AT, XT, PC, and compatible computers, and supply up to 8M bytes of memory.
- The Above Board Plus and Plus I/O work in IBM AT, XT, PC, and compatible computers, and supply up to 2M bytes of memory.
- The Above Board 286 and PS/286 work in IBM AT, XT, PC, and compatible computers and supply up to 2M bytes of memory. These boards were the industry's first switchless memory boards.
- The Above Board/AT and PS/AT work only in computers that are compatible with (and the height of) an IBM AT. The Above Board/AT supplies up to 2M bytes of memory, and the PS/AT supplies up to 1.5M bytes of memory.
- The Above Board/PC and PS/PC work only in IBM XT, PC, and compatible computers. The Above Board/PC supplies up to 2M bytes of memory, and the PS/PC supplies up to 1.5M bytes of memory.

---

The information in this manual is about the Above Board Plus 8 and Above Board Plus 8 I/O.

Appendix C in this manual describes using multiple Above Boards in a computer.

## **Address**

An address is a number that your computer uses to identify a byte of memory. Each byte of memory has a unique address, different from that of any other byte.

## **Application program**

An application program is the software you use to do your work on the computer. Some categories of application programs are word processors, database managers, spreadsheet managers, and project managers. Specific examples of application programs are MultiMate, dBase II, 1-2-3, Framework, and Symphony.

## **AUTOEXEC.BAT file**

An AUTOEXEC.BAT file is a special-purpose batch file. ("Batch file" is defined elsewhere in this glossary.) When you turn on your computer or restart it by pressing the Ctrl-Alt-Del key combination, DOS searches your system disk's root directory for the AUTOEXEC.BAT file. If DOS finds one, it executes the commands in the file.

---

## **Batch file**

A batch file is a special kind of file that contains DOS commands. It can save you time and effort by allowing your computer to execute more than one DOS command at a time. You can recognize batch files by the ".BAT" extension that follows the file name.

If you use a sequence of DOS commands frequently, you can create a batch file containing the commands, and then run the entire sequence by typing the name of the file. This reduces the number of keystrokes needed to run a sequence of commands.

## **COM1 and COM2**

DOS lets you attach up to two serial devices (usually serial printers, modems, or mice) to your computer. To keep track of which device you want to use, DOS assigns them names. COM1 and COM2 are the names. For more information about using serial printers with the Above Board's print buffer, refer to Chapters 13 and 15 in this manual.

## **Compatible computer**

Some manufacturers make computers similar to IBMs. These computers run most -- but sometimes not all -- the software that IBM computers run. These similar computers are called "IBM-compatible computers."

Some of these computers are less similar to the IBM AT, PC, or XT computer than others. This leads to the confusing question, "How compatible is a specific compatible?"

---

This manual uses the following definition. If a computer can run *all* the software that IBM personal computers can run, and can use *all* the hardware that IBMs can use, the computer is a compatible.

## **CONFIG.SYS file**

CONFIG.SYS is a special-purpose file. Among other things, it provides DOS with information about the kinds of hardware attached to your computer. Whenever you turn on your computer or restart it by pressing Ctrl-Alt-Del, DOS searches your system disk's root directory for the CONFIG.SYS file. If DOS finds one, it reads the commands from the file and adapts to your hardware.

## **Conventional memory**

Conventional memory is the memory that DOS recognizes and manages. This is limited to 640K bytes. (Some computers call conventional memory "base memory.")

In addition to conventional memory, the Above Board lets you add two other kinds of memory to your computer. This additional memory is called expanded memory and extended memory (for IBM AT and compatible computers only). Expanded memory and extended memory are defined elsewhere in this glossary.

Chapter 2 discusses all three kinds of memory in detail. Appendix D explains the technical aspects of expanded and extended memory, and Appendix E explains mappable conventional memory.

---

## Disk

In this manual, "disk" is a generic term meaning either hard disk or diskette.

## DOS

The letters D-O-S stand for Disk Operating System. DOS manages your computer's low-level functions, such as conventional memory, disk drives, printers, and the screen. This allows DOS-based application programs to focus on their tasks.

For more information about DOS, read the DOS manual that came with your computer. If you are new to computers, read *Running MS-DOS*, written by Van Wolverton and published by Microsoft Press. It's an unusually clear book designed for beginning computer users.

## Expanded memory

If you use DOS and DOS application programs, you'll want to use the Above Board to add expanded memory to your computer.

Expanded memory is memory above 640K that specially-written DOS application programs (such as Lotus 1-2-3 Release 2, Symphony Release 1.1, and Framework III) can use.

Each Above Board Plus 8 or Plus 8 I/O can provide up to 8M bytes of expanded memory for your programs to use. If you add the 6MB Piggyback Option (*for IBM AT and compatible computers only*), each Above Board Plus 8 or Plus 8 I/O can add 14M bytes of expanded memory to your computer.

---

Chapter 2 discusses Above Board expanded memory in detail. Appendix D explains the technical aspects of expanded memory.

## Expansion slot

An expansion slot is a space in your computer into which you can plug a board. Chapter 6 describes how to insert an Above Board Plus 8 and Plus 8 I/O in an IBM AT, XT, PC, IBM PS/2 Model 30, Model 30 286, and compatible computers.

## Extended memory

If you have an IBM AT or compatible computer and you use XENIX, VDISK, or OS/2, you may want to use the Above Board to add extended memory to your computer. *(Due to the limitations of IBM XT, PC or compatible computers, you can't add extended memory to them.)*

Extended memory is memory above 1024K bytes (1M byte) that only XENIX (defined elsewhere in this glossary), VDISK, and specially written programs such as AutoCAD can use. You *can't* use extended memory to run DOS application programs (such as Symphony). Some computers call extended memory "expansion memory."

If you use DOS and DOS application programs, you'll want to add *expanded* memory rather than extended memory.

Chapter 2 discusses Above Board extended memory. Appendix D explains the technical aspects of extended memory.



---

## **I/O**

I/O is an abbreviation for input/output.

### **I/O addresses**

An I/O address corresponds to an electrical connection that the boards in your computer use to communicate with the processor or brain of the computer. Although it permits data to flow between board and processor, the I/O address has no relationship to the expansion slot where the board resides.

Keep the following points about I/O addresses in mind:

- An I/O address can't be shared. If one board uses a specific I/O address, the other boards in your computer can't use the same address.
- There are a limited number (1024) of I/O addresses in each IBM AT.
- Many different kinds of boards are available for the AT, and most of them must use a specific I/O address or set of addresses.

These factors sometimes lead to conflicts. For example, two of the boards in your computer might be set to use the same I/O address.

To understand this conflict, think of telephones in two different houses having the same number. When someone calls the number, both phones ring, and both households answer. The ensuing conversation would be difficult to understand.

---

To prevent this type of conflict in your computer, the SETBOARD program lets you select one of several I/O addresses for each Above Board. Chapter 7 describes how to run the SETBOARD program.

### **LPT1, LPT2, and LPT3**

DOS lets you attach up to three parallel printers to your computer. To keep track of which printer you want to use, DOS assigns them the names LPT1, LPT2, and LPT3.

### **M bytes**

In publications relating to computers, M (for mega) means 1,048,576 or 1024K bytes. So, 1M byte is 1,048,576 bytes, and 4M bytes is 4,194,304 bytes.

### **Mappable conventional memory**

Mappable conventional memory is conventional memory supplied by your Above Board that is mapped in the same way that expanded memory is. You must use programs that are specially written to take advantage of it, such as Windows 2.0 and DESQview.

If your computer does not supply it on its system board, the Above Board may supply conventional memory between 256K and 512K, 256K and 640K, or 512K and 640K. By selecting the mappable conventional memory option in SOFTSET, or adding the MC parameter to the EMM line in your CONFIG.SYS file, this conventional memory can then be mapped. Appendix E explains the technical aspects of mappable conventional memory.

---

## **Nanoseconds**

A nanosecond is one billionth of a second. Many computer operations are so fast that they're measured in nanoseconds.

## **OS/2**

OS/2 is an operating system that manages conventional and extended memory, disk drives, printers, and the screen. It is a multitasking operating system, that can also run DOS programs in a window called the DOS compatibility box.

## **Page frame**

The page frame is the segment of your computer's higher memory that the Expanded Memory Manager uses to access expanded memory. This segment is somewhere between 768K and 896K for IBM AT and compatible computers. In IBM XT, PC, and compatible computers the segment is somewhere between 800K and 960K.

For IBM AT and compatible computers, the page frame lies within the 80286 processor's "real" address space (0 to 1024K) but beyond the memory that DOS manages for application programs (0 to 640K).

For IBM XT, PC, and compatible computers, the page frame lies within the address space of the 8088 or 8086 processor (0 to 1024K) but beyond the area DOS manages (0K to 640K).

---

The page frame acts as a gateway through which four (or more) 16K-byte blocks of memory, or pages, can be brought into the real address range of the 80286 processor. For a more detailed explanation and an illustration of how the page frame works, read Appendix D.

## **Parallel port**

A parallel port is a connector to which you can attach an IBM-compatible parallel printer. For additional information, see Chapter 14.

## **Parallel printer**

Two kinds of printers work with the IBM AT computer -- parallel and serial. Although most printers for IBM computers are parallel, serial printers are not rare.

The difference between the two is the way the computer sends the information to be printed. Put simply, parallel printers accept information one byte (8 bits) at a time, and serial printers accept information one bit at a time.

The difference is important because the Above Board print buffer works differently with serial and parallel printers. See Chapter 13 for more information about the print buffer (in general) and Chapter 14 for information about using a parallel printer.

## **Parity checking**

Parity checking is an error-detection technique used by many computers (including IBM personal computers) to verify the integrity of the data stored in memory chips while the computer is running.

---

## **PC-1 and PC-2**

In this manual, the terms PC-1 and PC-2 refer to the two versions of the IBM PC. You can recognize a PC-2, by the letter "B" stamped on the back panel of its system unit. PC-1s have no letter. (See Figure 7-2 in Chapter 7.)

## **Print buffer**

A print buffer is software that turns some of your computer's memory into a data storage area. The print buffer software uses this memory to store the data you send to the printer so you can use your computer while the printer is printing. Read Chapter 13 for more information about print buffers.

## **RAM**

The letters R-A-M stand for Random Access Memory. RAM is the kind of memory your application programs use to store data inside your computer.

RAM has the following characteristics:

- RAM is much faster than disk. Programs can read information from or write information to RAM in much less time than they could using a disk.
- RAM is volatile. When you shut off the power, the information stored in RAM is lost.

---

## **RAM disk**

A RAM disk is software that lets you use part of your computer's RAM as a very fast disk. If your programs frequently read from or write to disk, a RAM disk will speed them up substantially. For more information about RAM disks, read Chapter 12.

## **Restart**

Restarting (or rebooting) your computer is a technique for starting another program without turning your computer off.

If you don't have a hard disk, you can restart the computer by inserting a DOS system diskette in drive A and pressing the Ctrl-Alt-Del key combination.

If you have a hard disk, you can leave drive A empty and press the Ctrl-Alt-Del key combination. This will restart your computer from your hard disk.

## **ROM**

The letters R-O-M stand for Read-Only Memory. ROM is the kind of memory your computer uses to store information that never changes and is accessed frequently.

ROM has the following characteristics:

- Programs can read information from ROM, but they can't write any to ROM.
- ROM is non-volatile. When you shut off the power, the information stored in ROM is retained.

---

## **Serial port**

A serial port is a connector to which you can attach a serial device such as a printer or a mouse. For more information about serial ports, see Chapter 15.

## **Serial printer**

Two kinds of printers work with the IBM AT computer -- serial and parallel. Although most printers for IBM computers are parallel, serial printers are not rare.

The difference between the two is the way the computer sends the information to be printed. Put simply, serial printers accept information one bit at a time and parallel printers accept information one byte (8 bits) at a time.

The difference is important because the Above Board print buffer works differently with serial and parallel printers. See Chapter 13 for more information about the print buffer (in general) and Chapter 15 for information about using a serial printer.

## **System board**

The system board is a large, flat piece of fiber glass and metal, usually at the bottom of your computer. The system board contains the central processing unit, or brain, of the computer. It also contains some (or all) of the conventional memory in the computer. It is sometimes referred to as the "motherboard."

---

## **System disk**

A system disk is a disk from which you can start or restart your computer. It loads DOS into the computer and (optionally) starts running an application program. If your computer has a hard disk, the hard disk is the system disk.

Some application programs include diskettes labeled "system disk" that don't contain DOS and are, therefore, not really system diskettes. Newer versions of 1-2-3, Symphony, and Framework are examples of this type of application programs. In these situations, start or restart your computer from a DOS system disk first. Then run the application program from a separate diskette.

Be sure to install the Intel software on a system disk.

## **XENIX**

XENIX is an operating system that manages conventional and extended memory, disk drives, printers, and the screen.



---

# Index

## **Above Board**

computers compatible with 2-9  
defined Glossary-2  
determining which one you have 2-2  
hardware features 2-7  
memory capacity D-10  
power consumption D-8  
several in one computer Appendix C  
software features 2-10  
technical information Appendix D  
testing Chapter 9

## **Address Glossary-3**

### **Application program**

defined Glossary-3  
that use expanded memory 2-6

### **AUTOEXEC.BAT file**

defined Glossary-3  
modifications to 10-2, 15-6

### **Batch file**

AUTOEXEC.BAT 10-2, 15-6  
defined Glossary-4

### **Bulletin Board Service B-8**

---

## **Chips**

adding Chapter 4

inserting in a socket Appendix A

that work on the Above Board 4-5

## **CHKMEM program Chapter 11**

### **COM (COM1, COM2)**

defined Glossary-4

interrupts D-9

naming 15-3

parameters for F-23

### **Compatible**

computers 2-9, D-7

defined Glossary-4

display adapter boards 13-5

### **CompuServe, using to contact Customer Support B-6**

### **Confidence tests Chapter 9**

starting 9-3

worksheet 5-2, C-12

### **CONFIG.SYS file**

defined Glossary-5

modifications to 10-2

### **Conventional memory**

defined 2-5, Glossary-5

mappable 2-5, Appendix E

providing C-3, C-7

### **Customer Support information B-5**

### **Disk Glossary-6**

---

## **DOS**

defined Glossary-6

memory it supports 2-5, 2-6

version for expanded memory D-6

version for SOFTSET 10-4

## **Expanded memory**

defined 2-6, Glossary-6

how it works D-2

operating system for C-3, C-7

providing with multiple Above Boards C-4, C-8

setting up F-4, F-20

writing programs for D-6

## **Expansion slots**

16-bit 6-4, 6-5

8-bit 6-4, 6-5

defined Glossary-7

## **Extended memory**

defined 2-6, Glossary-7

providing with multiple Above Boards C-5

**Fax, using to contact Customer Support B-6**

**FaxBack, using to contact Customer Support B-7**

## **Hardware Worksheet Chapter 5**

for Above Board Plus 8 or Plus 8 I/O only 5-2

for multiple Above Boards in one computer C-10

---

## **I/O Glossary-8**

### **I/O addresses**

Above Board's base D-10

defined Glossary-8

parameters F-6

### **Installing the Above Board**

adding memory Chapter 4

in an IBM AT or compatible computer 6-2  
through 6-11

in an IBM PC, XT, or compatible computer  
6-12 through 6-20

in an IBM Personal System/2 Model 30 or Model 30 286  
6-20 through 6-29

inserting the board in the computer

Chapter 6

overview Chapter 3

running the computer's setup program  
Chapter 8

running the CHKMEM program Chapter 11

running the SOFTSET program Chapter 10

running the SETBOARD program Chapter 7

running the TESTAB program (confidence  
tests) Chapter 9

### **LPT (LPT1, LPT2, LPT3)**

defined Glossary-9

interrupts D-9

print buffer assignment 13-10

naming 14-4

parameters F-23

### **M bytes Glossary-9**

---

**Mappable conventional memory**  
about Appendix E  
benefit of 2-5  
defined Appendix E, Glossary-9

**MCI Mail, using to contact Customer Support B-6**

**Memory chips**  
adding Chapter 4  
inserting in a socket Appendix A  
that work on the Above Board 4-5

**Memory types**  
Conventional 2-5, Glossary-5  
Expanded 2-6, Glossary-6  
Extended 2-6, Glossary-7

**Multiple Above Boards Appendix C**  
in IBM AT and compatible computers C-2 to C-6  
in IBM PC, XT, and compatible computers C-7 to C-10

**OS/2**  
and extended memory 2-6  
defined Glossary-10

**Page frame**  
and expanded memory D-2 through D-6  
and mappable conventional memory E-2  
defined Glossary-10

---

**Parallel port Chapter 14**  
defined 14-2, Glossary-11  
cables 14-3  
interrupts D-9  
location on Above Board 14-2  
naming or disabling 14-4  
parameters F-23  
using C-6, C-9

**Parallel printer**  
cables for 14-3  
connecting 14-3  
defined Glossary-11

**Parity checking Glossary-11**

**Power consumption D-8**

**Power supply D-7**

**Print buffer Chapter 13**  
assigning to a printer 13-10  
command menu 13-5  
compatible display monitors 13-5  
defined Glossary-12  
messages 13-11  
setting up F-21  
with application programs 13-3  
with Local Area Networks (LAN) 13-4  
with serial printers 13-11, 15-4

**Printing**  
an ASCII file 14-6  
from an application program 14-6

**RAM Glossary-12**

---

**RAM disks Chapter 12**  
assigning a drive letter 12-8  
copying files to 12-9  
defined Glossary-13  
setting up F-21  
using with VDISK 12-7  
with application programs 12-4, 12-5

**Restart Glossary-13**

**ROM Glossary-13**

**Serial port Chapter 15**  
defined Glossary-14  
location on Above Board 15-3  
naming or disabling 15-3  
setting up 15-5  
using C-6, C-10

**Serial printer 15-4**  
defined Glossary-14  
using the MODE command 15-6

**Setup program**  
for IBM AT and compatible computers Chapter 8

**SETBOARD program Chapter 7**  
overview 7-1  
starting 7-4  
what to do before 7-3  
what to do after 7-8  
worksheet for 5-2, C-12

**SOFTSET program Chapter 10**  
starting 10-5  
what to do before 10-3

---

**Software**

backing up 10-5  
print buffer Chapter 13  
RAM disk Chapter 12  
CHKMEM Chapter 11  
SOFTSET Chapter 10  
SETBOARD Chapter 7  
TESTAB Chapter 9

**System disk Glossary-15**

**Technical information Appendix D**

**TESTAB Chapter 9**  
worksheet for 5-2, C-12

**Testing the Above Board Chapter 9**

**Troubleshooting Appendix B**

**VDISK RAM disk 12-7**

**XENIX**  
and extended memory 2-6  
defined Glossary-15



---

## **FIVE-YEAR LIMITED WARRANTY**

Intel warrants that the board delivered in this package will be free from defects in material and workmanship for five (5) years following the date of purchase. This warranty does not cover repair or replacement if the board is damaged in the process of being installed. Intel recommends that you have your dealer install this board.

THE ABOVE WARRANTY IS IN LIEU OF ANY OTHER WARRANTY, WHETHER EXPRESS, IMPLIED OR STATUTORY, INCLUDING BUT NOT LIMITED TO, ANY WARRANTY OF MERCHANTABILITY, FITNESS FOR ANY PARTICULAR PURPOSE, OR ANY WARRANTY ARISING OUT OF ANY PROPOSAL, SPECIFICATION, OR SAMPLE. INTEL DOES NOT ASSUME ANY OTHER LIABILITY AND DOES NOT AUTHORIZE ANY PERSON TO ASSUME OTHER LIABILITY FOR INTEL.

If the board is found to be defective, Intel, at its option, will replace the board at no charge except as set forth below, or refund your purchase price provided that you deliver the board, along with proof of purchase, either to the company from whom you purchased it or to Intel with an explanation of any deficiency. If you ship the board, you must assume the risk of damage or loss in transit. You must use the original container (or the equivalent) and pay the shipping charge.

Intel may replace your board with either new or reconditioned parts, and any replaced board becomes Intel's property.

This warranty does not cover replacement of boards damaged by abuse, accident, misuse, neglect, alteration, repair, disaster, improper installation, or improper testing.

INTEL WILL NOT BE HELD LIABLE FOR ANY LOSS OF PROFITS, LOSS OF USE, INCIDENTAL, CONSEQUENTIAL, OR SPECIAL DAMAGES CAUSED BY THE USE OF THIS BOARD OR INABILITY TO USE IT, EVEN IF THE DEALER OR INTEL HAS BEEN ADVISED OF SUCH LIABILITY OR OTHER SPECIAL CLAIMS.

---

INTEL PROVIDES ONLY THE WARRANTIES SET FORTH IN THIS FIVE-YEAR LIMITED WARRANTY. OTHER WARRANTIES, EITHER EXPRESS OR IMPLIED, SUCH AS WARRANTIES OF FITNESS FOR A PARTICULAR PURPOSE OR OF MERCHANTABILITY, ARE EXCLUDED. ALL WARRANTIES SET FORTH IN THIS WARRANTY ARE LIMITED TO FIVE YEARS FROM THE DATE OF PURCHASE. NO WARRANTIES WHATSOEVER WILL COVER THIS BOARD BEYOND FIVE YEARS. HOWEVER, SOME STATES DO NOT ALLOW TIME LIMITS TO BE IMPOSED ON IMPLIED WARRANTIES, SO SOME OF THESE LIMITATIONS MIGHT NOT APPLY TO YOU.

IF THIS BOARD IS NOT IN WORKING ORDER, YOUR ONLY REMEDY IS REPAIR OR REPLACEMENT, AS DESCRIBED ABOVE. UNDER NO CIRCUMSTANCES WILL INTEL BE LIABLE FOR CONSEQUENTIAL DAMAGES, INCLUDING ANY LOST SAVINGS, LOST PROFITS, OR ANY OTHER DAMAGES, CAUSED BY THE USE OF THIS BOARD OR INABILITY TO USE IT, EVEN IF THE DEALER OR INTEL HAS BEEN ADVISED OF SUCH LIABILITY OR OTHER CLAIMS.

SOME STATES PROHIBIT EXCLUSION OR LIMITATION OF DAMAGES FOR CONSUMER PRODUCTS. IF YOU LIVE IN ONE OF THESE STATES, THESE LIMITATIONS MIGHT NOT APPLY TO YOU. THIS WARRANTY PROVIDES YOU WITH SPECIFIC LEGAL RIGHTS, AND YOU MAY HAVE OTHERS, DEPENDING UPON THE STATE IN WHICH YOU LIVE.

---

## **SOFTWARE LICENSE AGREEMENT**

The accompanying software is furnished subject to the terms and conditions of this license. Should you choose not to be bound by the terms and conditions of this license, you should promptly return this software, and any separate license fee paid to Intel for this software and its accompanying documentation will be refunded.

You may not use, copy, merge, modify, or transfer the software or any copy or portion of it unless provided for in this agreement.

### **License**

Under the terms of this license:

- 1** You may use the software only on a single computer at a time.
- 2** You may not modify the software.
- 3** You may not lease or otherwise rent the software.
- 4** You may not decompile or disassemble the software.

### **Transfer of Ownership**

You may transfer ownership of this license to another party only if you:

- 1** Also transfer ownership of your associated Intel hardware, if applicable, and
- 2** Require the other party to abide by the terms of this license agreement, and

- 
- 3 Destroy all copies of the software that you do not transfer to the other party.

### **Ownership and Copyright of the Software**

Although the diskettes containing the software are yours, the software is owned and copyrighted by Intel and/or its suppliers. You may not remove the copyright notice from the software. You will use your best efforts to prevent any unauthorized copying of the software.

### **Taxes**

You must pay all property taxes that may now or hereafter be imposed, levied, or assessed with respect to the possession or use of the software or this license. You shall file all reports required in connection with such taxes.

### **Backup Policy**

You may copy the software solely for backup or archival purposes.

---

## **Limitation of Liability**

THE SOFTWARE IS PROVIDED "AS IS" WITHOUT WARRANTY OF ANY KIND INCLUDING WARRANTIES FOR MERCHANTABILITY OR FITNESS FOR A PARTICULAR PURPOSE. NEITHER INTEL NOR ITS SUPPLIERS SHALL BE LIABLE FOR ANY LOSS OF PROFITS, LOSS OF USE, INTERRUPTION OF BUSINESS, NOR FOR INDIRECT, SPECIAL, INCIDENTAL, OR CONSEQUENTIAL DAMAGES OF ANY KIND WHETHER UNDER THIS AGREEMENT OR OTHERWISE.

## **Limitation of Remedies**

Intel does not warrant the functions provided by the software. However, Intel warrants the media on which the program is furnished to be free from defects in materials and workmanship under normal use for a period of one year from the date you purchased it. Intel's entire liability to you and your exclusive remedy shall be the replacement of the software if the medium on which the software is furnished proves to be defective.

## **U.S. Government Restricted Rights**

The software is provided with restricted rights. Use, duplication, or disclosure by the U.S. Government is subject to restrictions as set forth in subparagraph (c)(1)(ii) of the Rights in Technical Data and Computer Software clause at 52.227-7013 or its successor.

intel

# The Above™ Board Guide to making good software better.

Today, the 640K of conventional memory you get with DOS just isn't enough to support your favorite software programs. As your software has gotten more sophisticated, the amount of memory it needs has increased. As a result, you're probably getting a lot of "memory full" messages. An Intel Above Board, with its expanded memory, will solve this problem. Expanded memory on Above Board gives your software the room it needs to perform well for you.

Once the Above Board is installed, your software can use expanded memory in a variety of ways. This guide will help you understand how your favorite application takes advantage of expanded memory. We've organized the software programs by category and coded them to show how they use the extra room an Above Board provides.

## Here's what those codes mean:

1. Your software can use expanded memory as a place to put data for quick and easy access. So you won't need to worry about running out of memory and your data won't take up your precious 640K of conventional memory.
2. Some software will load your actual program into Above Board expanded memory. Again, you'll get more of your 640K of conventional memory freed up for other work.
3. These applications save you time and increase your productivity by putting files to be printed in a buffer of Above Board

expanded memory. You can continue working while your files are being printed.

4. Above Board gives you the memory you need to open more than one program at a time. The Above Board and your multi-tasking software let you run applications in background while you work in the foreground.

Intel makes an Above Board for every PC and compatible. If you'd like more information, contact your local dealer, or call Intel direct at 800/538-3373. Every Above Board is backed by Intel's industry leading, five-year warranty and toll free support.



## COMPUTER AIDED DESIGN

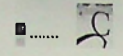


**AutoCAD**  
Autodesk, Inc.  
800-445-5415  
(1)

**VERSACAD**

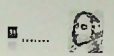
**VersaCAD**  
Versacad Corporation  
714-960-7720  
(1)

**TURBO C**



**Turbo C 2.0**  
Borland International  
800-543-7543  
(1)

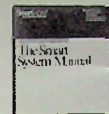
**TURBO PASCAL**



**Turbo Pascal 5.0**  
Borland International  
800-543-7543  
(1,2)



**SAS System**  
SAS Institute Inc.  
919-467-8000  
(2)

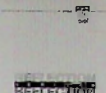


**The Smart Software System**  
Informix Software, Inc.  
800-get-smart  
(1,3)

## NETWORKS/COMMUNICATIONS



**Fetch**  
Thought Dynamics  
213-546-2958  
(2)



**Reflection 4 PLUS Rel 3.0**  
WalkerRichter & Quinn  
800-872-2829  
(1,2)

## DATABASES



**Turbo Prolog**  
Borland International  
800-543-7543  
(1)



**FoxBase +**  
Fox Software Inc.  
419-874-0162  
(1)



**FrontRunner**  
Ashton-Tate Corp.  
213-538-7601  
(1)



**MARVIN**  
Ovnic Imaging Systems Inc.  
800-451-7566  
(1)

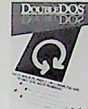
## OPERATING ENVIRONMENTS



**Carousel**  
Softlogic Solutions Inc.  
800-272-9900  
(2)



**DESQview 2.2**  
Quarterdeck Office Systems  
213-392-9851  
(2,4)



**Double DOS**  
Softlogic Solutions Inc.  
800-272-9900  
(2,4)



**Library**  
WordPerfect Corporation  
801-225-5000  
(2)

## GRAPHICS/IMAGING



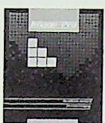
**Paradox**  
Borland International  
800-543-7543  
(1,2)



**Professional File**  
Software Publishing Corp.  
415-962-0191  
(1)



**Q&A 3.0**  
Symantec Corp.  
408-253-9600  
(1)



**Image Pro**  
Media Cybernetics Inc.  
800-992-HALO  
(1,3)



**Windows/286 v2.1**  
Microsoft Corp.  
800-426-9400  
(1,2)

## OPERATING SYSTEMS



**DOS 4.0**  
IBM Corp.



**DESQview Companions I**  
Quarterdeck Office Systems  
213-392-9851  
(1)

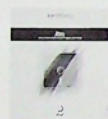


**Ready!**  
Living Videotext, Division of Symantec  
408-446-9994  
(1,2,3)

## PRODUCTIVITY/PLANNING



**Publisher's Paintbrush**  
ZSoft Corporation  
404-428-0008  
(1,3)



**RIO**  
AT&T Graphics Software Labs  
317-844-4364  
(1)



**TIPS**  
True Vision, Inc.  
800-858-TRUE  
(1,3)



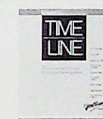
**TOPAS**  
AT&T Graphics Software Labs  
317-844-4364  
(1,2)



**Reflex**  
Borland International  
800-543-7543  
(1)



**ThinkTank**  
Living Videotext, Division of Symantec  
408-446-9994  
(1,2)



**Time Line 3.0**  
Symantec Corp.  
408-253-9600  
(1)

## PROGRAMMING TOOLS



**Analyst**  
Turbo Power Software  
408-438-8608  
(1)

## INTEGRATED PRODUCTS



**AlphaWorks**  
Alpha Software Corporation  
617-229-2924  
(1,2)



**Framework III**  
Ashton Tate Corp.  
800-437-4329  
(1)



**Microsoft Works**  
Microsoft Corp.  
800-426-9400  
(1)



**Symphony Rel 2.0**  
Lotus Development Corporation  
617-623-6572  
(1)



**Development Tools Catalog 1988**  
Intel Corporation  
800-874-6835  
(call for information)



**Halo 88**  
Media Cybernetics, Inc.  
800-992-HALO  
(1,3)



**Information Engineering Workbench**  
KnowledgeWare, Inc.  
800-338-4130  
(1,2)



**Lumena**  
Time Arts, Inc.  
707-576-7722  
(1)

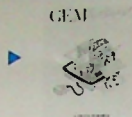
## PUBLISHING



**T-Debug Plus 4.0**  
Turbo Power Software  
408-438-8608  
(1)



**Turbo Professional**  
Turbo Power Software  
408-438-8608  
(1)



**GEMArt**  
Digital Research  
800-443-4200  
(1)



**GoScript**  
Lasergo Inc.  
619-590-2400  
(1,3)



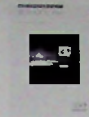
**PC Tools**  
Central Point Software Inc.  
503-690-8050  
(1,2)



**Personal REXX**  
Mansfield Software  
Group, Inc.  
203-429-8402  
(1)



**PRD+**  
Productivity Software  
International  
212-967-8666  
(1)



**SideKick Plus**  
Borland International  
800-543-7543  
(1,2)

## SPREADSHEETS



**Halo DPE**  
Media Cybernetics Inc.  
800-992-HALO  
(1,3)



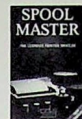
**Publisher's Type Foundry**  
ZSoft Corporation  
404-428-0008  
(1,2,3)



**Excel**  
Microsoft Corp  
800-426-9400  
(1,2)



**Javelin**  
Javelin Software Corp.  
800-JAVELIN  
(1)



**SPOOL MASTER**  
Spool Masters, Inc.  
800-25-FLASH  
(1)



**The Analyst**  
Symantec, Turner-Hall  
Publishing Division  
800-888-0886  
(1)



**Tree 86**  
The Aldridge Co.  
719-953-1940  
(1)



**Worksheet Utilities**  
Funk Software Corporation  
800-822-3865  
(1,2)

## WORD PROCESSING



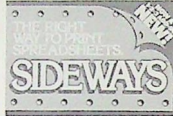
**1-2-3 Rel. 2.0**  
Lotus Development Corp.  
617-623-6572  
(1)



**PlanPerfect**  
WordPerfect Corporation  
801-225-5000  
(1,2)



**Quattro**  
Borland International  
800-543-7543  
(1)



**Sideways**  
Funk Software, Inc.  
800-822-3865  
(1,2)



**Professional Write**  
Software Publishing  
Corporation  
415-962-0191  
(1)



**WordPerfect 5.0**  
WordPerfect Corporation  
801-225-5000  
(2,3)

## UTILITIES



**SuperCalc5**  
Computer Assoc  
International, Inc  
408-432-1764  
(1)



**Back To DOS**  
Software Masters, Inc.  
800-25-FLASH  
(2)



**Flash**  
Software Masters, Inc.  
800-25-FLASH  
(1)

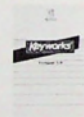


**Kedit 4.0**  
Mansfield Software  
Group, Inc  
203-429-8402  
(1)

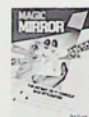
Above and below are trademarks of Intel Corporation. Other brand and product names are trademarks of their respective owners. 059/029/88/160-300/13 014



**Keyworks Advanced**  
Alpha Software  
Corporation  
617-229-2924  
(1,2)



**Keyworks 3.0**  
Alpha Software  
Corporation  
617-229-2924  
(1,2)



**Magic Mirror**  
Softlogic Solutions Inc.  
800-272-9900  
(1,2)




**Pageview**  
Microsoft Corp.  
800-426-9400  
(1,2)

Intel Personal Computer Enhancement Operation  
CO3-7  
5200 N.E. Elam Young Parkway  
Hillsboro, Oregon 97124-6497  
503/629-7354  
800/538-3373



# Intel BBS



## is available on the BBS?

The Intel BBS contains a wide variety of information and services. Including:

- ◆ The latest Intel software (available for downloading to your modem).
- ◆ Late-breaking announcements about Intel products and promotions, Intel product information (compatibility reports, application notes, prices, etc.)
- ◆ A message service.

You can leave questions for Intel Customer Support technicians or participate in question and answer forums with Intel and other users.



## use the BBS?

### It's fast...


The BBS can send the latest Intel software to your modem immediately. No more waiting for a diskette in the mail.

### It's easy to use...

The BBS's menu guide you quickly to the information you need.

### It's always available...

The BBS is ready to help you 24 hours a day, every day.



## does the BBS work?

To use the Intel BBS, all you need is a modem. This rolodex card lists the Intel BBS number and explains how to set up your modem. Punch out the card and keep it handy. With the BBS number nearby, you're never far from Intel customer support. No matter what time it is.

**Intel BBS<sup>24</sup> CUSTOMER  
HELLO! SUPPORT**

**503 645-6275**

Before you call the Intel BBS, set your modem as follows:

- 300, 1200, or 2400 bits per second
- 8 data bits
- 1 stop bit



intel

# Intel Above™ Board Software Guide

OCTOBER 1, 1986

The software packages on this list support the Lotus/Intel/Microsoft Expanded Memory Specification (EMS). Most can address up to 8MB of memory above 640K, available on any member of the Intel Above Board product family; check with the software manufacturer for the maximum amount of expanded memory usable by a specific product.

Your favorite software may not be on this list; in this case, contact the software manufacturer to learn about their plans to support the Lotus/Intel/Microsoft EMS. Otherwise, see your local computer dealer to find out more about purchasing Intel's Above Board and any of the packages listed.

Information on hardware appears on the reverse side.

COMPANY	PACKAGE	PHONE
<b>Spreadsheets</b>		
Lotus Development	Lotus 1-2-3 Rel. 2.0 & above	617-577-8500
Javelin Software	Javelin	617-494-1400
Computer Associates	SuperCalc3	408-942-1727
<b>Databases</b>		
Borland Analytica	Reflex	408-438-8400
Gryphon Microproducts	dB/RA 3	301-946-2585
Information Builders	PC/Focus	212-736-4433
Software Publishing	Pis: Professional File	415-962-8910
<b>Integrated Products</b>		
Ashton-Tate	Framework II	213-329-8000
Lotus Development	Symphony Rel. 1.1 & above	617-577-8500
Innovative Software	Smart	913-492-3800
<b>Multi-tasking and Program-Swapping Products</b>		
Microsoft	Windows	206-882-8080
Quarterdeck	Desqview	213-392-9851
Softlogic Solutions	Software Carousel, Double DOS	603-627-9900
<b>Disk Cache Utilities</b>		
PC Support Group	Lightning	214-351-0564
Software Masters	Flash Rel 4.5	317-253-8088
Multisoft	Super PC Work	503-642-7108
<b>Programming Tools</b>		
KnowledgeWare	Information Engineering Workbench	313-971-5363
Turbo Power	Turbo Extender	408-378-3672
Time Arts	Lumina	707-576-7722
Nantucket	Clipper, Autumn '86	213-390-7923
<b>Utilities</b>		
Living Videotext	Ready, Thinktank	415-964-6300
Maxamedia Corporation	Maxam Plus	303-450-5209
Turner Hall Publishing	Note-It	408-253-9607
<b>Computer Aided Design</b>		
T & W Systems	VersaCAD	714-847-9960
Autodesk	AutoCAD	415-332-2344
<b>Graphics Products</b>		
Media Cybernetics	Dr. Halo, Ver. 2.6	301-495-3305

## Many Software Products Run Faster from Above™ Board RAM Disks.

Although they do not address memory beyond 640K, many software products run faster from the RAM Disks included with each Above Board. The list includes too many products to name. The popular packages which benefit from Above Board RAM Disks include:

COMPANY	PACKAGE	PHONE
Ansa	Paradox	800-547-3000
Ashton-Tate	Multimate Advantage, dBASE III Plus	213-538-7365
Borland International	Turbo Lightning	408-438-8400
IBM	Displaywrite 3	800-426-3333
Microsoft	Word	206-882-8080
Microrim	R BASE 5000	800-547-4000

### Above Board Product Features

#### Above Board PS/AT

- Serial port and parallel port.
- Three kinds of memory — conventional from 512K to 640K, and up to 1.5MB of expanded and/or extended memory (up to 3.5MB with Piggyback option).
- For all IBM PC ATs, Compaq 286s and Portables II's and other true compatibles.

#### Above Board/AT

- Three kinds of memory — conventional from 512K to 640K, and up to 1.5MB of expanded and/or extended memory (up to 3.5MB with Piggyback option).
- For all IBM PC ATs, Compaq 286s and Portables II's and other true compatibles.

#### Above Board PS/PC

- Serial port, parallel port, and clock/calendar.
- Two kinds of memory — conventional from 256K to 640K, and up to 2MB of expanded memory.
- For all IBM PCs, XT's; Compaq Deskpro 86s, Pluses and Portables; and other true compatibles.

#### Above Board/PC

- Two kinds of memory — conventional from 256K to 640K, and up to 2MB of expanded memory.
- For all IBM PCs, XT's; Compaq Deskpro 86s, Pluses and Portables; and other true compatibles.

### All Above Boards include:

- **Installation software:**  
Menu-driven for quick, easy setup.
- **Expanded Memory Manager:**  
True DOS device driver.  
"Fail soft" test of memory chips.
- **RAM disk software:**  
Multiple RAM disks.  
Maximum size 8MB.  
30% faster than DOS 3.0 VDISK on an AT.
- **Print buffer software:**  
Pop-up menu for control of buffer within application.  
Works with parallel or serial printers.  
Pop-up support for IBM Color Graphics, IBM Monochrome, and Hercules display adapters (and compatibles).
- **User-oriented documentation:**  
Installation Guide for first-time users.  
"Shortcuts Guide" for sophisticated users.
- **Memory diagnostics**
- **Five-year warranty**
- **Continental US and Canadian 800 numbers for technical support**

The claims of compatibility and suitability of the products discussed in this document are made by the product's manufacturer, not by Intel Corporation. While Intel Corporation makes every effort to ensure that the information in this publication is accurate, Intel will not be liable for any damages whatsoever arising from errors or omissions of fact contained herein.

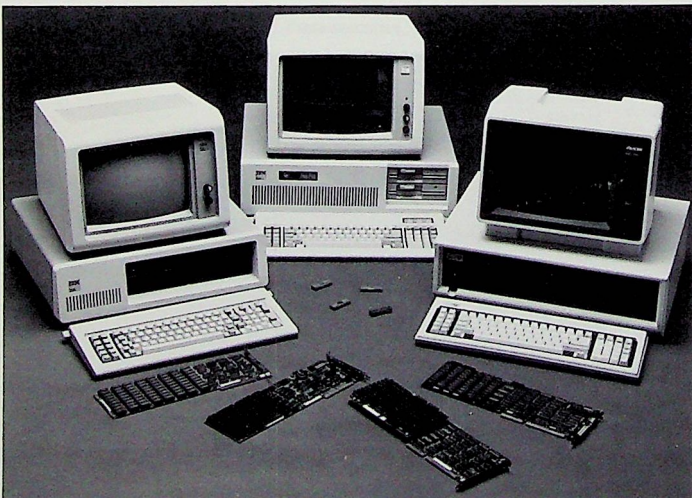
The companies and products named in this document are trademarks of their manufacturers.

Printed in U.S.A. Copyright © 1986, Intel Corporation. All rights reserved. 300713-001B MC 1505



### Personal Computer Enhancement Operation TOD-07

5200 NE Elam Young Parkway  
Hillsboro, OR 97124  
(800) 538-3373 (outside Oregon and in the U.S.)  
(800) 235-0444 (in Canada)  
(503) 629-7354 (in Oregon, Alaska, and Hawaii)



# **RECENT NEWS ABOUT ABOVE™ BOARD PLUS AND PLUS 8**

*Read this before you read the manual*

## ***New README file***

A README file is now included on the Above Board software installation disk. This file contains troubleshooting and compatibility information, such as what to do if you have a 16-bit VGA card in your system. To access this file, switch to the drive that contains the installation disk (typically drive a:) and type README. Intel's new SHOW utility then allows you to scroll through the README file, using the arrow, Page Up, Page Down, Home, and End keys. Type Esc to exit README file.

## ***Support for more mappable pages***

You can now use any unused page in the address range C800 to EFFF (for IBM PC, XT, and compatible computers) and C000 to DFFF (for IBM AT and compatible computers) for page swapping of expanded memory pages. A contiguous 64K-byte page frame must still be provided, but additional non-contiguous pages can also be used for page swapping.

If the EMM command is included in your CONFIG.SYS file without any EXPF or EXPL commands, EMM automatically searches the address range from C800 to EFFF (for PC and XT computers) or from C000 to DFFF (for AT computers) for the presence of ROM or RAM. It then selects all the available pages in this range for page swapping.

Two new EMM parameters are provided to support this feature. **CP** (contiguous pages) and **EP=x** (exclude pages). The CP parameter forces EMM to set up a page frame of at least 64K bytes that contains only contiguous pages. This parameter is provided for use with applications that require a page swapping area made up of contiguous pages only.

The above changes locate the Token Ring ROM at address CC00 and the shared RAM at address C800. This operation relieves the memory conflict and opens up the a 64K-byte page frame for EMM.SYS at addresses D000 through DFFF.

PCEO  
301695-003  
J#901718

---

## QUICK INSTALLATION FOR THE ABOVE BOARD PLUS 8 AND PLUS 8 I/O

This sheet lists the steps to install the Above Board Plus 8 or Plus 8 I/O. If you need additional information, turn to the appropriate chapter in the *Installation Guide for the Above™ Board Plus 8 or Plus 8 I/O*.

- 1 Add memory** to the Above Board Plus 8 or Plus 8 I/O. See Chapter 4.
- 2 Fill out one of the Hardware Worksheets.** You'll need this information later. See Chapter 5 or Appendix C.
- 3 Insert the Above Board in your computer.** See Chapter 6.
- 4 Run the SETBOARD program.** This program sets up conventional and extended memory, and controls naming of the parallel and serial ports. See Chapter 7.
- 5 Set the computer's switches** (*for IBM PC and compatible computers only*). See Chapter 7.
- 6 Run the computer's setup program** (*for IBM AT and compatible computers only*). See Chapter 8.
- 7 Run the TESTAB program.** This program checks the memory chips on the Above Board. See Chapter 9.
- 8 Run the SOFTSET program.** This program installs the Above Board software to provide expanded memory, RAM disks, and a print buffer. See Chapter 10. You can also manually install this software. See Appendix F.
- 9 Run the CHKMEM program.** This program lists the amount of conventional, expanded, and extended memory in your computer. See Chapter 11.

If you have questions about the Above Board, contact Intel's Customer Support. Appendix B in the manual tells you how.