

LC24-100

MULTI-FONT

USERS MANUAL

NOT INTENDED FOR SALE

QBA 80825557

VDE Statement

This device carries the VDE RFI protection mark to certify that it meets the radio interference requirements of the Postal Ordinance No. 243/1991. The additional marking "Vfg. 243/P" expresses in short form that this is a peripheral device (not operable alone) which only individually meets the Class B RFI requirements in accordance with the DIN VDE 0878 part 3/11.89 and the Postal Ordinance 243/1991.

If this device is operated in conjunction with other devices within a set-up, in order to take advantage of a "General (Operating) Authorization" in accordance with the Postal Ordinance 243/1991, the complete set-up must comply with the Class B limits in accordance with the DIN VDE 0878 part 3/11.89, as well as satisfy the preconditions in accordance with § 2 and the prerequisites in accordance with § 3 of the Postal Ordinance 243/1991.

As a rule, this is only fulfilled when the device is operated in a set-up which has been type-tested and provided with a VDE RFI protection mark with the additional marking "Vfg 243".

Machine Noise Information Ordinance 3. GSGV, January 18, 1991: The sound pressure level at the operator position is equal or less than 70dB(A) according to ISO 7779.

The above statement applies only to printers marketed in Germany.

Trademark Acknowledgements

LC24-100, LC24-20, LC24-200, LC24-10, SF-10DV, SPC-8K: Star Micronics Co., Ltd.

IBM-PC, PS/2, PC-AT, PC-DOS: International Business Machines Corp.

MS-DOS, Microsoft BASIC, Windows: Microsoft Corporation

LQ-860, LQ-850: Seiko Epron Corp.

NOTICE

- All rights reserved. Reproduction of any part of this manual in any form whatsoever without STAR's express permission is forbidden.
- The contents of this manual are subject to change without notice.
- All efforts have been made to ensure the accuracy of the contents of this manual at the time of press.
However, should any errors be detected, STAR would greatly appreciate being informed of them.
- The above notwithstanding, STAR can assume no responsibility for any errors in this manual.

HOW TO USE THIS MANUAL

This manual is organized into eleven chapters. To learn how to make the best use of your printer you are urged to read through chapters 1 through 6. Chapters 7 through 11 may be treated as a reference guide for programming operations, etc. It assumes a degree of knowledge of the operation of computers. The chapters are as follows:

Chapter 1 – Introduction

This chapter indicates the primary features of your printer, the names and functions of the printer components, and an actual example of the many font styles that your printer can produce.

Chapter 2 – Setting Up the Printer

This chapter explains how to get the printer unpacked and set up. Read this chapter before you do anything else.

Chapter 3 – Paper Installation and Use

This chapter describes the instructions for printing such as selecting paper types, adjusting the printing gap, and installing paper.

Chapter 4 – Control Panel Operations

There are a number of controls on the front panel which perform various functions related to paper handling, print modes and font selection.

After performing the setup of the printer, read this chapter and try out the procedures to find out how the printer works.

Chapter 5 – Default Settings – EDS mode

This chapter explains how to set the Electronic DIP Switch (EDS) mode to make your printer match your system and software needs.

Chapter 6 – Troubleshooting

This section shows a list of check points to follow if your printer is not working properly. It also includes details of some routine maintenance operations you can perform yourself. It is not, however, a complete service manual. Call your authorized service center if you are unsure of your ability to carry out any maintenance or servicing operations on the printer.

Chapter 7 – Optional Accessories

This chapter explains the optional accessories that are available for your printer, and how to install and use them.

Chapter 8 – Printer Control Commands

This chapter explains the software commands that are used to drive your printer. This section is of use if you are writing or modifying programs to take advantage of the printer's features.

Chapter 9 – Download Characters

This chapter explains the procedures to create your own characters.

Chapter 10 – MS-DOS and Your Printer

Since the PS/2 or PC-AT family of computers running under MS-DOS is currently the most popular configuration of microcomputer, we have included a few hints and tips to help you use your printer with such systems.

Since virtually all PCs are sold with a Microsoft BASIC interpreter, we have also included some hints, and a sample program in this language to demonstrate the capabilities of the printer.

Chapter 11 – Reference

This section provides references for your printer, such as specifications, the pinout of interface connector, and the character tables.

The character table charts give the different character sets available.

TABLE OF CONTENTS

Chapter 1 INTRODUCTION	1
Printer components	2
Summary of printer features	4
Font style example	6
Chapter 2 SETTING UP THE PRINTER	7
Printer placement	7
Unpacking and inspection	8
Setting up	9
Installing the platen knob	9
Removing the front cover	10
Installing the ribbon cartridge	11
Installing the front cover	12
Installing the paper guide	13
Connecting the interface cable	13
Configuring your software for the printer	15
Chapter 3 PAPER INSTALLATION AND USE	17
Selection of paper	17
Adjusting the printing gap	18
Loading fanfold forms	19
Paper parking	22
Paper unparking	23
Tear off function	24
Loading single sheets	25
Chapter 4 CONTROL PANEL OPERATIONS	27
Button and indicator functions	27
ON LINE	28
PAPER FEED	28
PITCH	29
FONT	29
Power-up functions	30
Short test mode	30
Long test mode	31
Pitch lock mode	32
Font lock mode	32

Font and Pitch lock mode	32
Dot adjustment mode	32
Hexadecimal dump	34
Switch combination functions	35
Form feed	35
Paper parking	35
Top of form	36
Forward micro-feed	36
Reverse micro-feed	36
Changing the auto loading position	37
Clearing the buffer/All reset	37
Save macro definition	38
Conditions indicated by beep tones	39
Chapter 5 DEFAULT SETTINGS – EDS MODE	41
How to set the EDS mode	41
Functions of the EDS settings	42
Chapter 6 TROUBLESHOOTING	47
Chapter 7 OPTIONAL ACCESSORIES	53
Automatic Sheet Feeder	53
Setting up	54
Loading paper	57
Interface Converter	59
DIP switch functions on the converter	60
Chapter 8 PRINTER CONTROL COMMANDS	61
Font control commands	62
Character set commands	66
Character size and pitch commands	68
Vertical position commands	72
Horizontal position commands	77
Graphics commands	80
Download character commands	83
Other printer commands	85

Chapter 9 DOWNLOAD CHARACTERS	89
Assigning the character data	90
Assigning a value of character space	91
Sample program	91
Chapter 10 MS-DOS AND YOUR PRINTER	95
Programming the printer with DOS commands	95
Programming with BASIC	98
Chapter 11 REFERENCE	105
Specifications	105
Pinout of interface connector	108
Parallel interface	108
Serial interface	109
Character sets	110
Italic character set #2	111
International character sets	113
Graphics character set #2	114
Character set #1	121
INDEX	123
COMMAND SUMMARY	127

Chapter 1

INTRODUCTION

This printer has a full complement of features, making it an excellent partner for a personal computer. It supports the Epson printer commands and character sets, enabling it to print just about anything your computer can generate, both text and graphics.

The selection of paper you can use is as varied as the types of documents you can produce. This printer accepts any of the following papers:

- Single sheets (cut forms) and stationery
- Fanfold forms (continuous forms)
- Multi-part forms
- Preprinted forms

This Multi-font printer has the following resident (internal) fonts which you can print:

- Draft
- Roman
- Sanserif
- Courier
- Prestige
- Script

The control panel has four buttons and ten indicators. The indicators display and beep tones provide immediate, easy to understand feedback when you press the buttons on the control panel.



The four buttons can operate in combinations to perform a surprising variety of functions, including saving a micro.

The Paper Parking function enables you to keep fanfold forms parked in readiness while printing on single sheet paper.

To get acquainted with the printer's components and capabilities, refer to the information on the pages that follow.

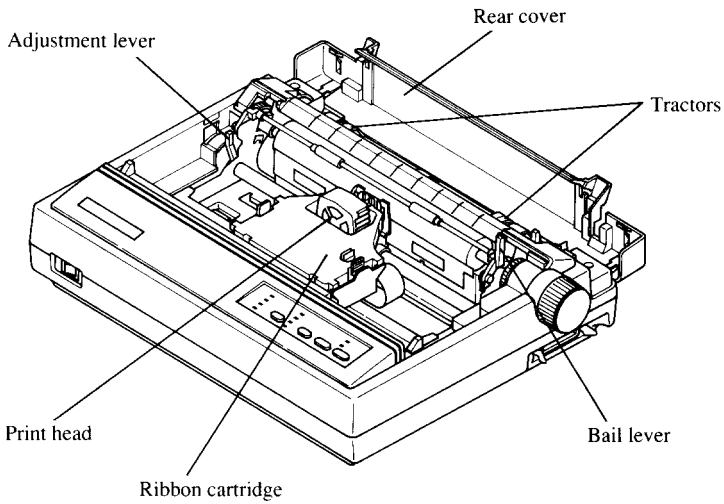
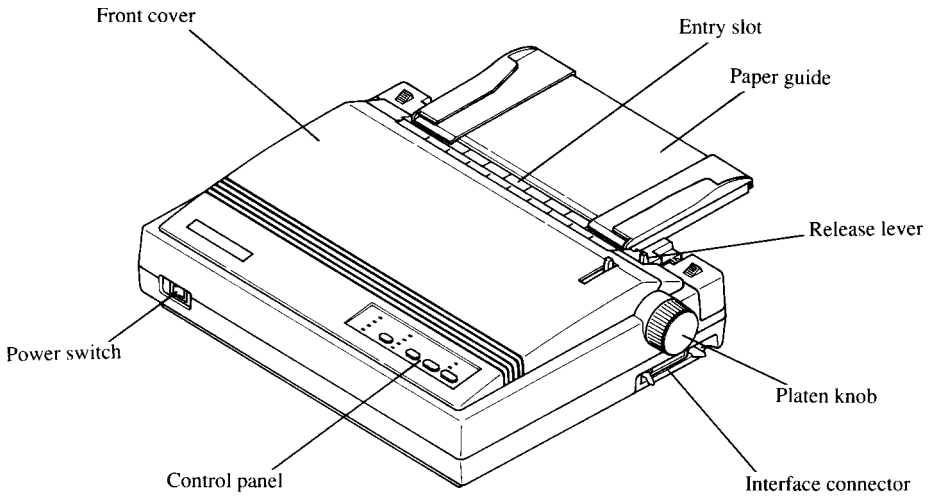
PRINTER COMPONENTS



Component	Description
Paper guide	Aligns single sheets (cut forms) to help the printer detect when paper is inserted.
Release lever	Releases pressure on the paper. This lever must be back for cut-sheet forms (), and forward for fanfold forms ().
Front cover	Protects the print head and other internal components of your printer.
Rear cover	Protects the tractor feed unit and separates incoming and outgoing fanfold forms.
Entry slot	For inserting single sheets of paper.
Control panel	Indicates printer status and makes various control of printer functions simple and convenient.
Power switch	Switches power on or off.
Platen knob	Advances the paper manually.
Interface connector	Connects the computer to the printer.
Print head	Has a high resolution dot matrix (24-wire) composition for outstanding print quality.
Ribbon cartridge	Contains the printer ribbon.
Adjustment lever	Controls print darkness by adjusting for the thickness of forms being printed.
Tractors	Control the movement of fanfold forms.
Clamp lever	Clamps the tractor in place.
Bail lever	Opens and closes the paper bail which holds the paper against the platen. This lever is also used to load paper.

SUMMARY OF PRINTER FEATURES

Feature	Function
Dot matrix (24-wire) impact printing	Draft and Letter-Quality printing.
Extensive software support	It is compatible with the Epson standard, and works with any software that supports those printers.
Multi-font support	This printer includes Draft, Roman, Sanserif, Courier, Prestige, and Script fonts.
Carriage size	A standard carriage that prints on fanfold forms up to 254 mm (10 inches) wide and cut forms up to 215.9 mm (8.5 inches)wide.
Multi-speed printing	In Draft mode, prints at speeds up to: <ul style="list-style-type: none">• 240 CPS in 15 pitch• 192 CPS in 12 pitch• 160 CPS in 10 pitch In Letter-Quality mode, prints at speeds up to: <ul style="list-style-type: none">• 80 CPS in 15 pitch• 64 CPS in 12 pitch• 53 CPS in 10 pitch.
Charactor spacing	Prints in 10, 12, 15, 17, and 20 CPI, as well as proportional spacing.
Control panel	Button control for fonts, pitches, paper movement, and paper park functions.
Font/Pitch Lock	Ignores font and pitch selections sent from your computer, and stays on the selected font and pitch with the control panel.
Quiet mode	Reduces printing noise by approximately 50%. However, printing speed is also reduced.
Graphics printing	Standard graphics printing with resolution of up to 360 x 360 dots per square inch. It also supports the NEC graphics commands.

Feature	Function
Paper parking	Parks fanfold paper. You can print on cut sheet paper without unloading the fanfold forms.
Print styles	Highlighting capability with the following emphasis styles: <ul style="list-style-type: none"> • Double-high • Double-strike • Double-wide • Emphasized • Italics • Outline • Overlining • Shadow • Subscript • Superscript • Underlining.
Tear off function	Fanfold forms can be removed without advancing blank forms.
Multi-part forms	Prints up to three-part forms.
Ribbon cartridge	Contains the printer ribbon.
EDS mode	Electronic DIP Switch (EDS) mode allows you to easily change the default settings of your printer to match your system and software needs.
CDM function	This printer can use the Compressed Data Mode (CDM), which has been sent with the exclusive printer driver. CDM is useful for a speed-up data communication between host computer and printer, especially in case of bit-image data (Windows environment).

Chapter 2

SETTING UP THE PRINTER

This chapter describes the following procedures to set up your new printer. If you have optional accessories, refer to Chapter 7 after setting up the printer.

- Printer placement
- Unpacking the carton box
- Installing the platen knob
- Installing the ribbon cartridge
- Connecting the printer to your computer
- Configure your software for the printer

PRINTER PLACEMENT

Before you start setting up your printer, make sure that you have a suitable place on which to locate it. By “a suitable place”, we mean:

- A firm, level surface which is fairly vibration-free
- Away from excessive heat (such as direct sunlight, heaters, etc)
- Away from excessive humidity
- Away from excessive dust
- A steady power supply that is not subject to power surges should be connected to the printer.
For example, do not connect it to the same circuit as a large, noise-producing appliance such as a refrigerator or an air conditioner.
- Make sure the line voltage is the voltage specified on the printer’s identification plate.
- Install the printer where there is sufficient room for the fanfold paper stack and any paper being fed in or printed out.
- If you are connecting your printer with a parallel interface, make sure that the cable is within 2m (6ft) of the printer. An RS-232 connection using the optional SPC-8K interface converter can be made over longer distances.

UNPACKING AND INSPECTION

Now check each item in the box against Figure 2-1 to make sure that you have everything (there should be five items).

If any of these items are missing, contact your supplier.

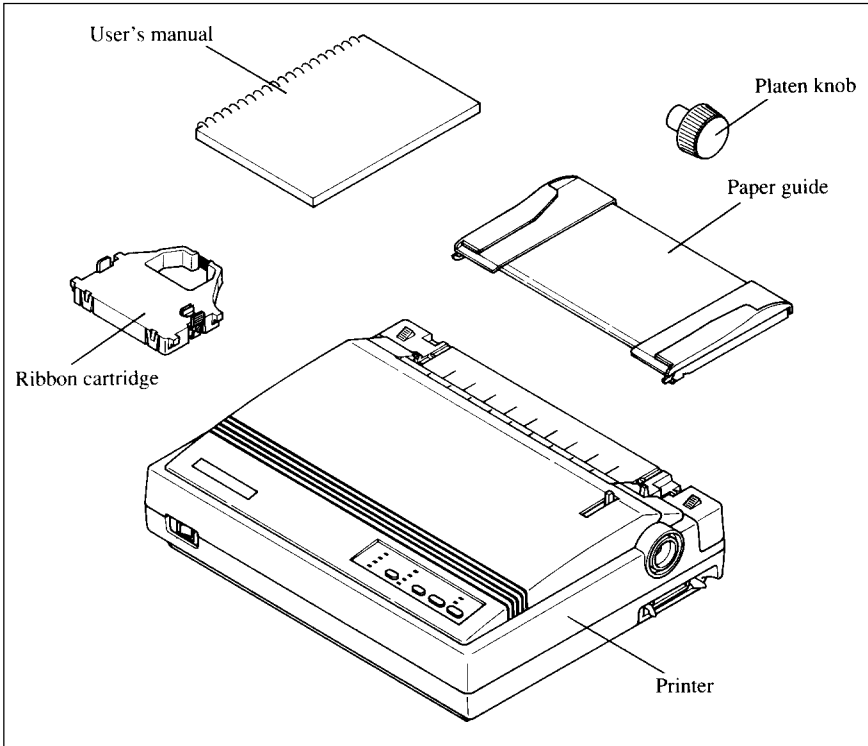

Figure 2-1. Check to make sure you have all five items: 1) Printer, 2) Platen knob, 3) Ribbon cartridge, 4) Paper guide, and 5) User's manual.

The optional accessories which you may have ordered with your printer are:

- Serial-Parallel converter (SPC-8K)
- Automatic sheet feeder (SF-10DV)

For details of the optional accessories, refer to Chapter 7.

SETTING UP

Place the printer in the desired location, and remove all packing material from the printer. This packing material is intended to prevent damage to the printer while in transit.

You will want to keep all the packing material, along with the printer carton, in case you have to move the printer to a new location.

Installing the platen knob

The platen knob is packed into a recess of the cardboard packing material which held your printer inside the carton. Be sure to remove the knob from the packaging.

Align the knob on the platen shaft, which is located on the right-hand side of the printer. Rotate the knob on the shaft before pushing the knob fully into position.

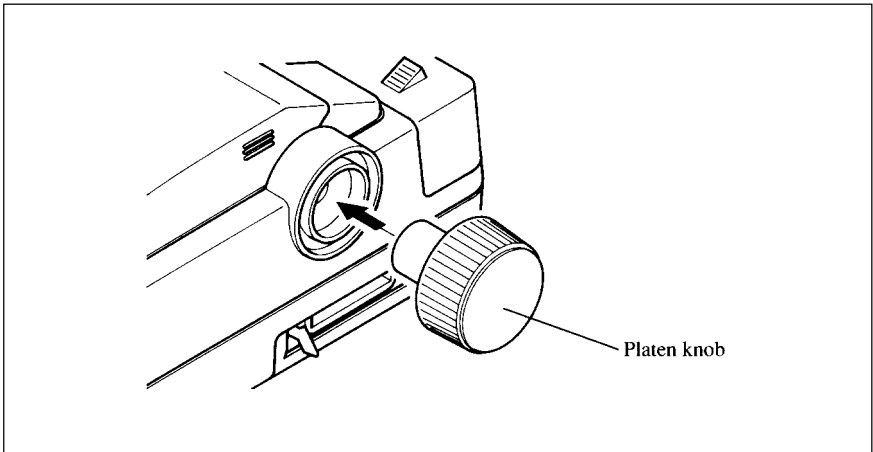

Figure 2-2. Installing the platen knob.

Removing the front cover

Open the front cover by lifting up the back cover using the two grips on either side, then remove the cover by pulling up (see Figure 2-3).

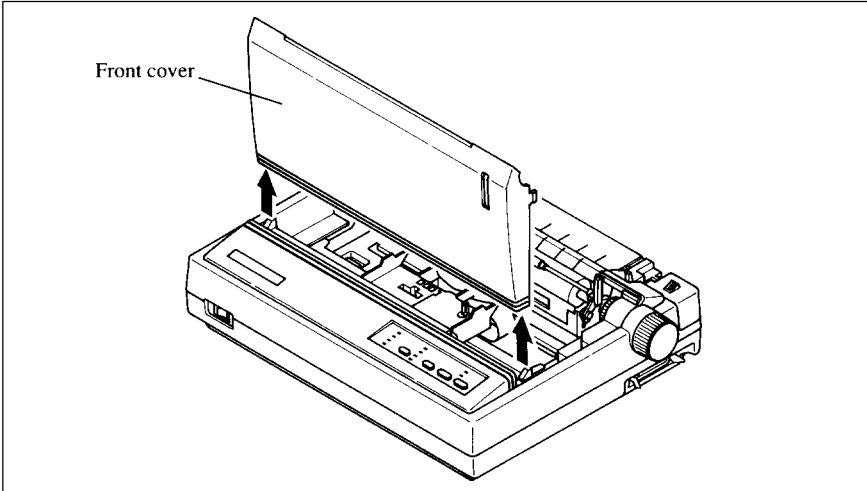

Figure 2-3. Open the front cover, and remove it by pulling up.

NOTE: You can keep the front cover installed on the printer, as shown in Figure 2-4. But, in this case you must take care not to injure your fingers with the tear assist edge.

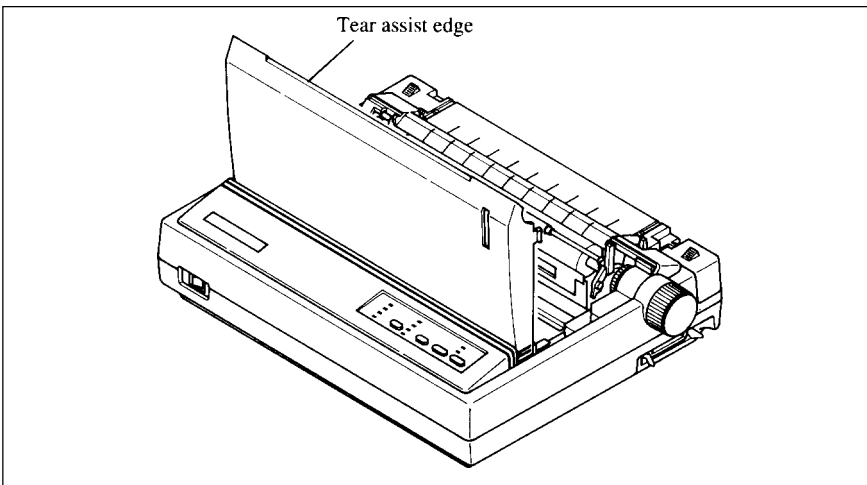

Figure 2-4. The front cover can stay on the printer.

Installing the ribbon cartridge

Now install the ribbon with the following procedure.

1. Take the slack out of the ribbon by turning the tension knob on the ribbon cartridge clockwise as shown by the arrow.

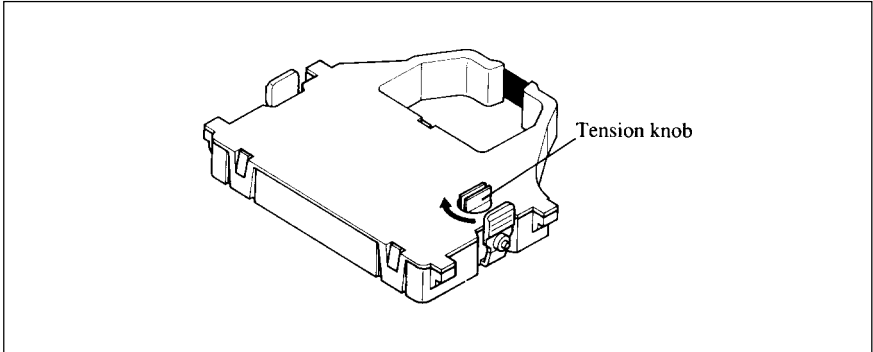

Figure 2-5. Take out the slack of the ribbon by turning the tension knob on the ribbon cartridge.

2. Guide the ribbon between the print head and the silver print head shield, making certain that the spindles on the cartridge holder fit into the sockets on the cartridge itself.

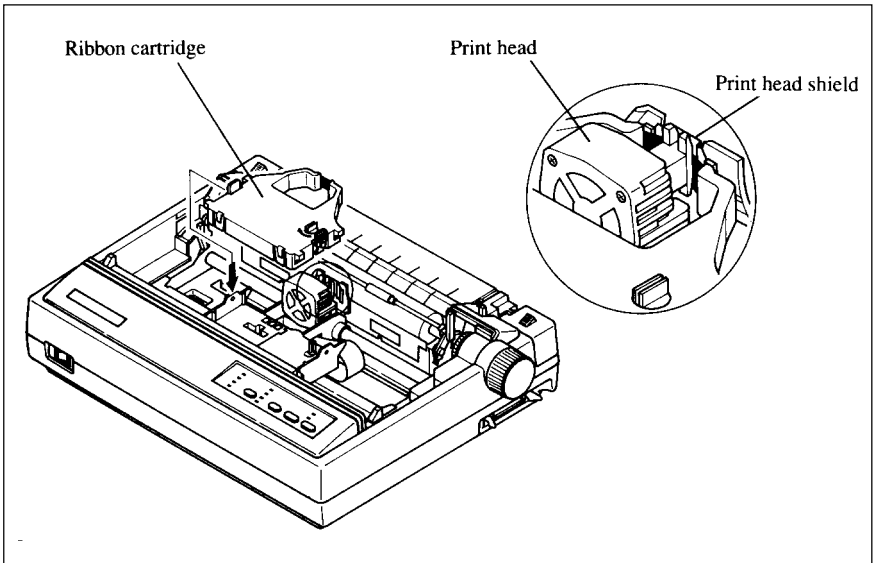

Figure 2-6. Installing the ribbon cartridge.

3. Make sure that the ribbon is positioned between the print head and the print head shield as shown in Figure 2-6.
4. Take the slack out of the ribbon again by turning the tension knob.

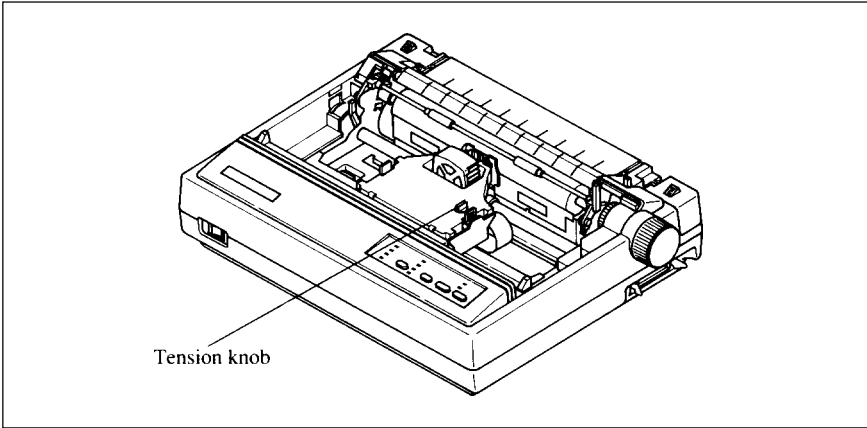

Figure 2-7. Make sure that the ribbon is positioned correctly.

Installing the front cover

After you have installed the ribbon cartridge, re-install the front cover.

1. Insert the tabs into the slots on the printer case.
2. Swing down the rear of the front cover to close it.

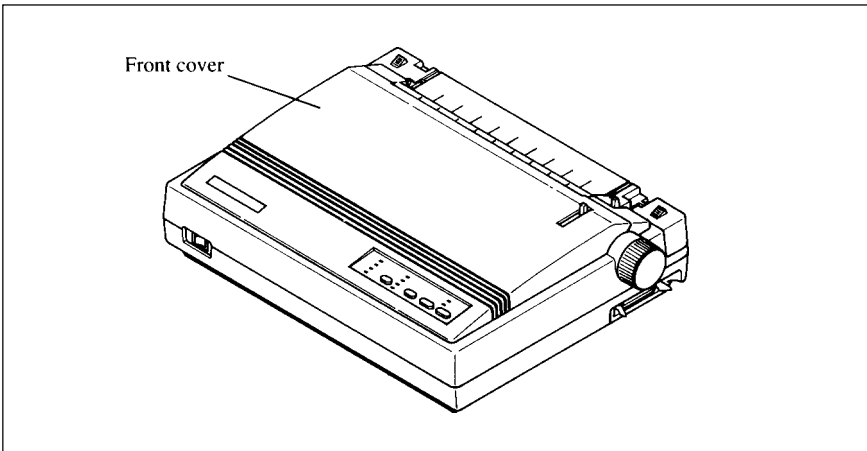

Figure 2-8. Swing down the rear of the front cover after insert the tabs into the slots of the printer case.

Leave the front cover closed during normal operation. The cover keeps out dust and dirt and reduces the printer's operating sounds. Open the cover only to change the ribbon or make an adjustment.

Installing the paper guide

Follow the procedure below to install the paper guide:

1. Insert the two slots on either side of the paper guide into the two tabs on the rear cover, as shown in Figure 2-9.
2. Place the paper guide horizontally to use fanfold forms, and vertically to use single sheets.

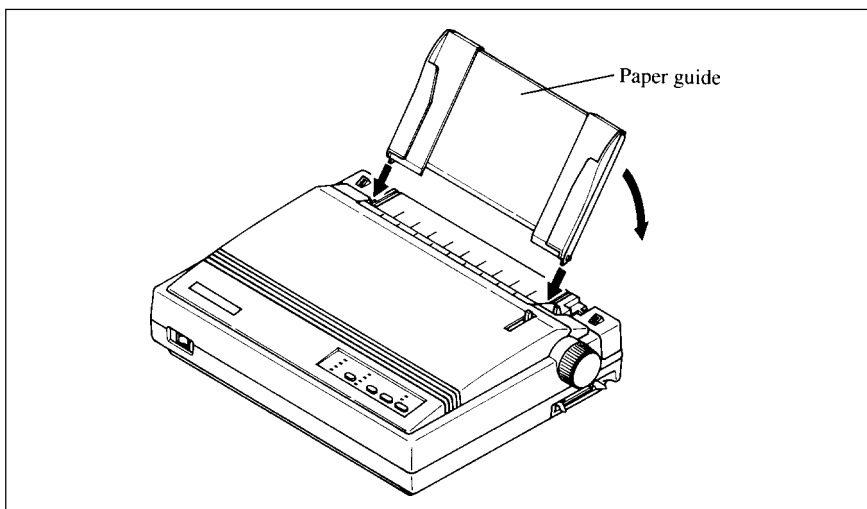

Figure 2-9. Installing the paper guide.

Connecting the interface cable

Connect the printer to your computer using a standard Centronics parallel interface cable. On a PS/2 or PC/AT-type computer, this means that you use the 25-pin D-type connector at the computer end, and the Amphenol-type 36-pin connector at the printer end. The configuration of the printer's connector is given in Chapter 11 should you need a cable for connecting to another computer.

If you need to connect to a serial port, use the optional Serial-Parallel Converter, SPC-8K.

Follow the procedures below to connect the interface cable:

1. Turn off the power switch both the printer and the computer.
2. Connect the interface cable to the printer as shown in Figure 2-10. Make sure that you press the plug into the interface connector.

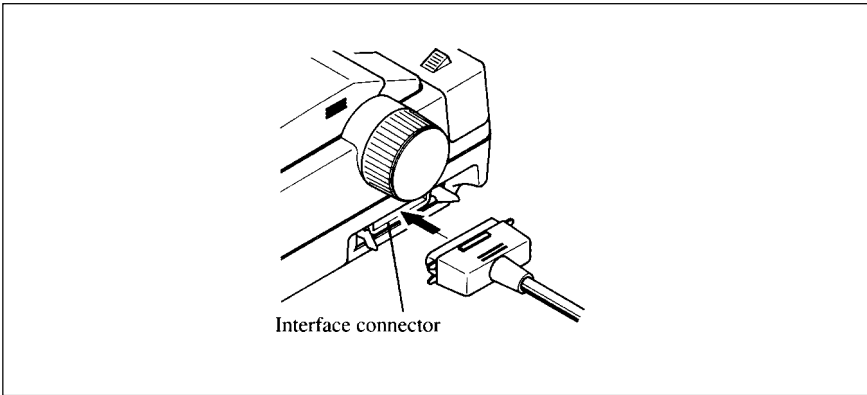

Figure 2-10. Connecting the interface cable.

3. Move both clips inside the extended prongs on the sides of the plug until you hear a click.

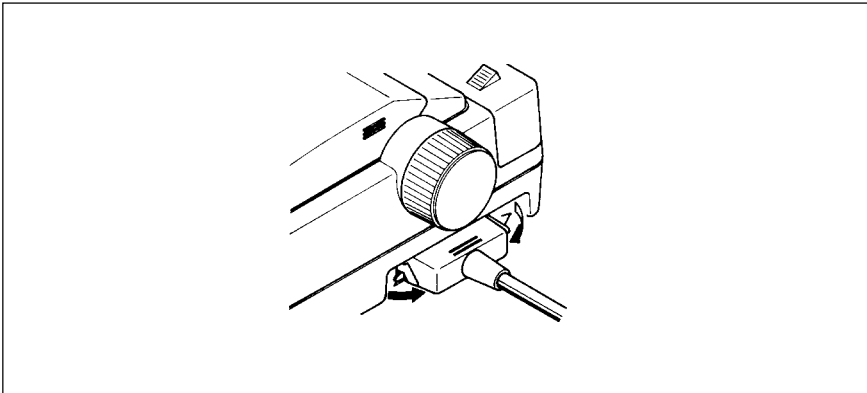

Figure 2-11. Move the clips until you hear a click.

4. Connect the other end of the interface cable to your computer. Use your computer instructions to attach the interface cable.

Configuring your software for the printer

Most application software programs let you specify the type of printer you are using so that the software can take full advantage of the printer's features.

Many of these software packages provide an installation or setup program that presents a list of printers.

Choose one of the following (in order of preference):

#	Printer Name
1	Star LC24-100
2	Star LC24-10
2	Star LC24-200
3	Epson LQ-860
4	Epson LQ-850
5	Star LC24-10

You can also select one of NEC 24-wire printers to print graphics.

If your software package does not mention printers by name, but asks instead what features your printer is capable of, the most common questions are: "Can your printer perform a backspace?" and "Can it do a hardware form feed?". You should answer "Yes" to both these questions.

Make sure that the Electronic DIP Switch (EDS) is set for the correct printer condition, and that you have also selected the appropriate character set. (Refer to Chapter 5 for detailed information on the EDS mode.)

If you are in doubt about the configuration of your application software, seek expert advice. Your software supplier will probably be your most qualified reference.

MEMO

Chapter 3

PAPER INSTALLATION AND USE

This chapter describes instructions for printing such as selecting paper types, adjusting the printing gap, and installing paper.

SELECTION OF PAPER

Your printer accepts any of the following types of paper:

- Single sheets (cut forms) and stationary
Use the friction feed or the optional Automatic Sheet Feeder.
- Fanfold forms
Fanfold forms have holes along the sides and perforations between the sheets. They are also called sprocket forms, continuous forms, or just plain “computer paper”.
Printing on or near the perforations of continuous fanfold forms may reduce printing quality, misalign the fanfold forms, or cause a paper jam.
- Multi-part forms
You can use multi-part forms that have up to three parts including the original.
Use pressure sensitive multi-part forms with both side edges glued and a difference in thickness of 0.05mm or less between the side edges.

Figure 3-1 shows the recommended print area for each type of papers.

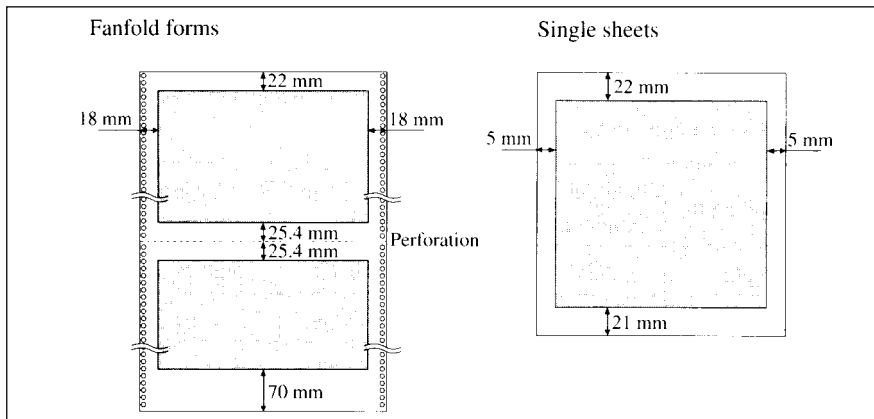

Figure 3-1. Recommended print area for acceptable papers.

ADJUSTING THE PRINTING GAP

The distance between the print head and the platen can be adjusted to accommodate different paper thicknesses. The adjustment lever is located at the left side of the printer. Pushing the adjustment lever towards the rear of the printer narrows the gap; pulling it towards the front of the printer widens the gap.

There are five positions, and you can feel the lever clicking into each position. The second position from the rear (marked with “•”) is the one most commonly used for single sheets of paper.

Try different positions until you get the best printing results.

NOTE: Printing with an inappropriate gap may drastically shorten the life of the print head.

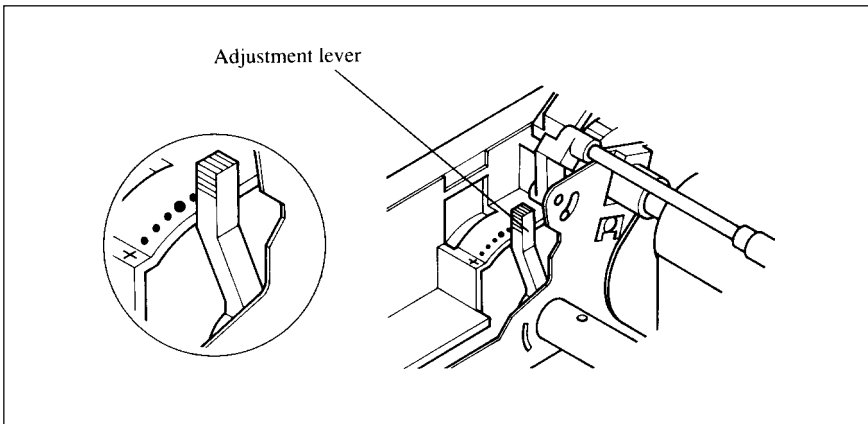

Figure 3-2. Location of the adjustment lever.

The following table provides the recommended lever positions for each paper types as a reference.

Paper Type	Weight(g/m ²) (Each sheet)	Thickness(mm) (Total)	Recommended Lever position
Single	52 to 90	0.07 to 0.12	2nd or 3rd
2-ply	40 to 52	0.12 to 0.14	2nd or 3rd
3-ply	40 to 52	0.18 to 0.21	3rd or 4th

LOADING FANFOLD SHEETS

This printer accepts fanfold forms up to 10" wide.

This printer can feed fanfold forms from the rear of the printer, as shown in Figure 3-3.

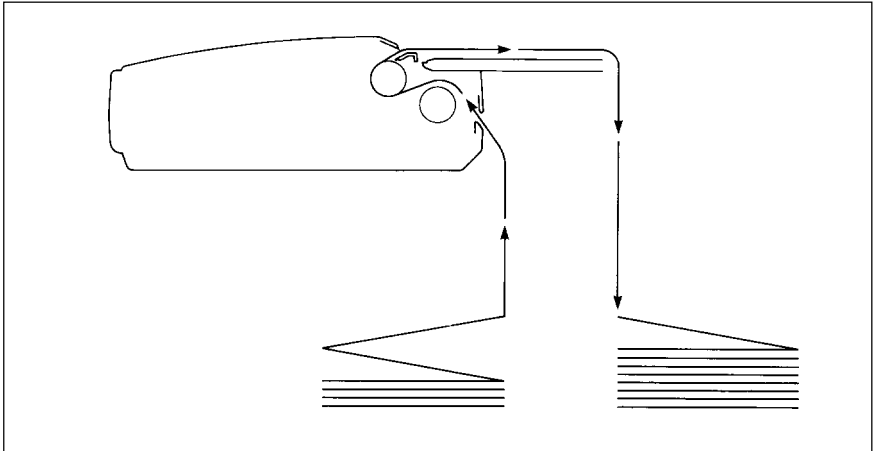



Figure 3-3. Paper path for fanfold forms.

This section will take you through the procedures for loading, parking and unparking fanfold forms.

1. Place a stack of fanfold paper behind and below the printer.
2. Turn the printer's power OFF.
3. Pull the release lever toward the front of the printer (). This has the effect of releasing the paper from the platen roller, and engaging the tractor feed.

4. Open the rear cover using the two grips on either side, as in Figure 3-4.

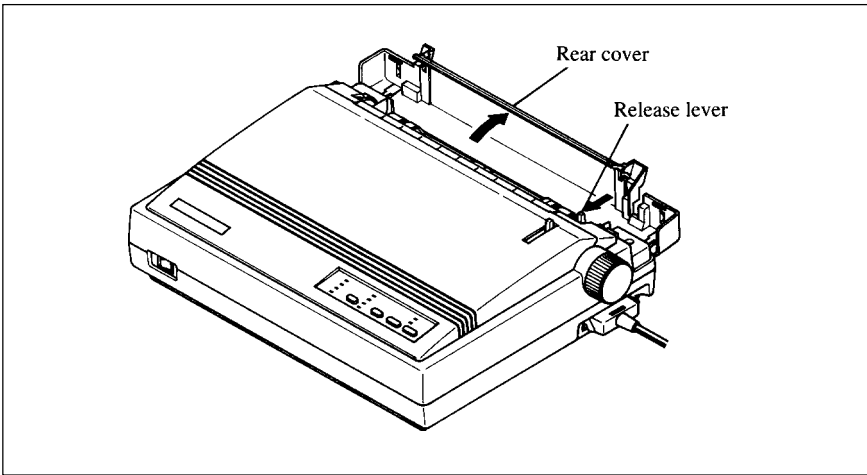

Figure 3-4. Opening the rear cover.

5. Pass the paper between the printer case and the rear cover.
6. Open both tractor covers and mount the paper by aligning holes with the pins on the tractor unit.

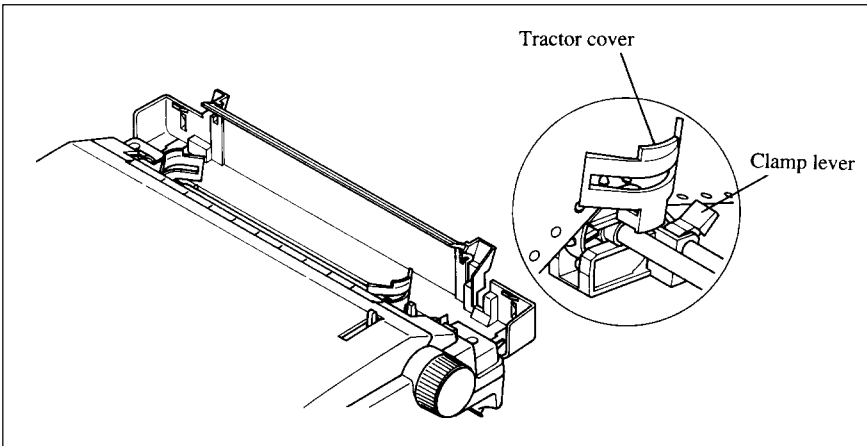

Figure 3-5. Mount the fanfold paper over the tractor units.

7. Adjust the spacing of the tractor units by sliding them along the bar, using the clamp lever at the back of each unit to release and lock them in position. When the clamp lever is down, the unit is released, and when it is up, the unit is locked.

- Now close the tractor covers, again making sure that the paper holes are aligned with the pins on the tractor units. If they are not aligned properly, you will have problems with paper feeding, possibly resulting in tearing and jamming of the paper.

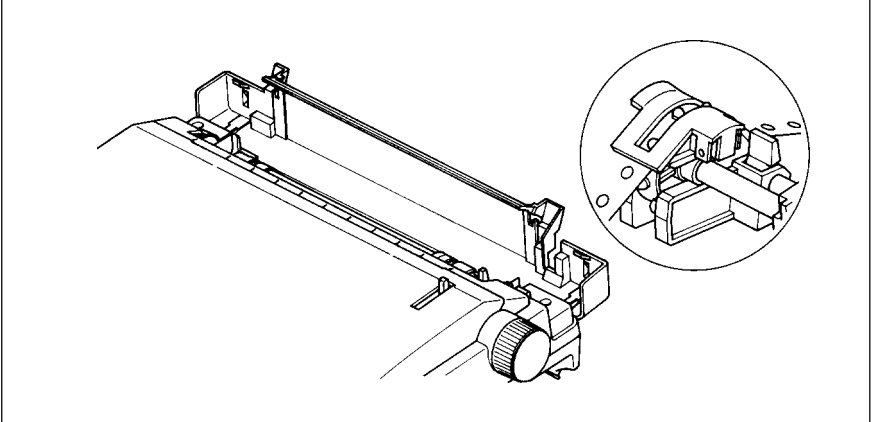

Figure 3-6. Adjust the tractor positions to accommodate the width of fanfold forms.

- Close the rear cover, then set the paper guide in the horizontal position, as shown in Figure 3-7. This will separate the printed from the unprinted paper.

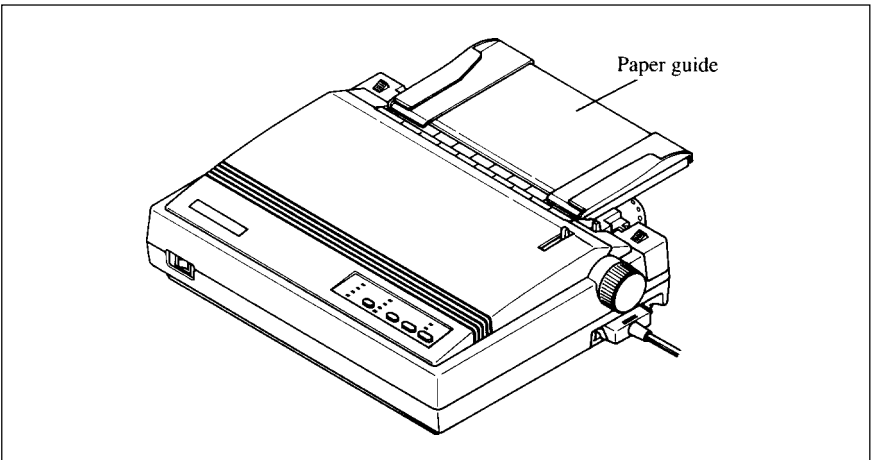

Figure 3-7. Close the rear cover, then set the paper guide horizontally.

- Turn on the power using the switch located at the front of the printer. The printer will beep, indicating that the paper is not yet fully loaded. The POWER indicator will also flash on the control panel to confirm this.

11. Now pull the bail lever toward the front of the printer. The paper will be fed and adjusted past the print head to a position ready for printing.

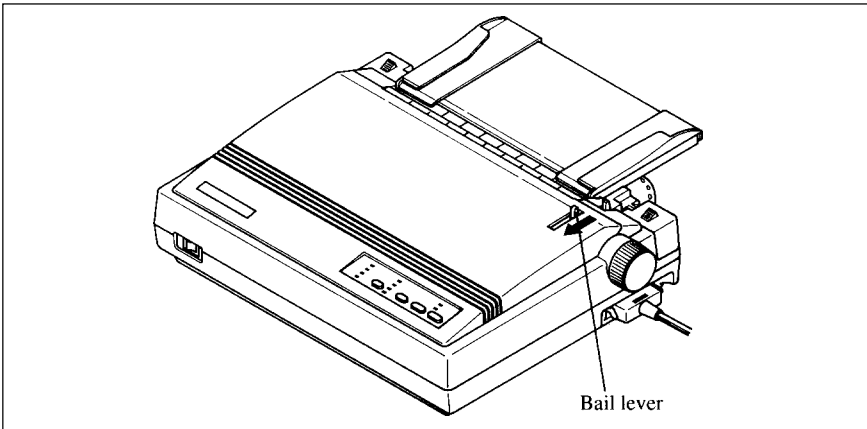



Figure 3-8. Pull the bail lever toward the front of the printer to load paper.

NOTE: Do not return the bail lever backward before the paper goes through under the bail lever location. The printer indicates with the beep tones to close the bail lever after the paper goes through under the bail lever location.

12. If you want to set the paper to a different position, set the printer off-line by pressing the **ON LINE** button, then set the paper by using the micro-feed function. (For details, refer to Chapter 4.)

Paper parking

After loading fanfold paper, you need not to unload it when you want to print on a cut sheet. The printer will “park” it for you if you follow the procedure below.

1. To begin paper parking, start with the power ON, fanfold paper loaded in printing position, and the release lever toward the front of the printer ().
2. Press the **ON LINE** button on the control panel to set the printer off-line. The **ON LINE** indicator will turn off.
3. Tear off the printed form at the last perforation, leaving not more than about half a page showing above the front cover. If necessary, press the **PAPER FEED** button to feed paper forward until a perforation is located just above the front cover, and tear there.

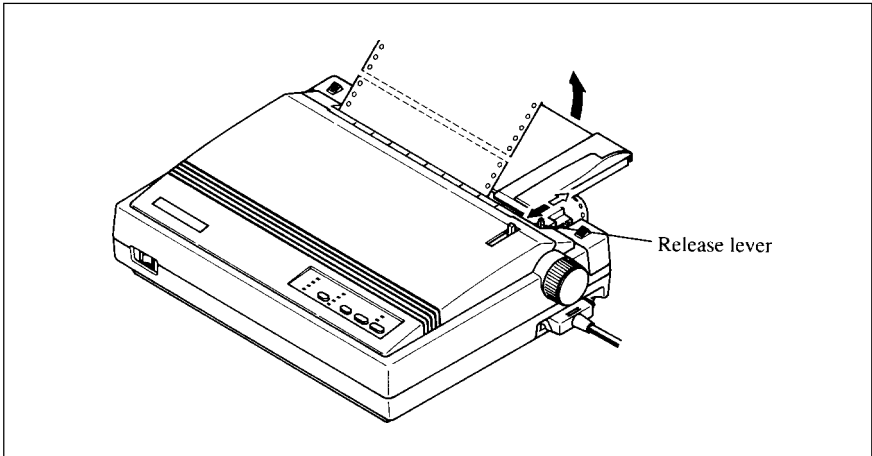



Figure 3-9. Tear off the printed fanfold paper.

4. Press the **PAPER FEED** button while holding the **FONT** button on the control panel.
The printer will automatically feed the fanfold form backward until the paper is completely free of the platen.
5. The **POWER** indicator on the control panel will blink and a beep will sound.
6. Move the release lever toward the rear of the printer ().
7. Mount the paper guide in the upright position.

Now you can load single sheets. The fanfold paper remains parked at the back of the printer.

Paper unparking

When you want to resume using fanfold paper, the procedure is as follows.

1. Remove all cut forms from the printer.
2. Mount the paper guide in the horizontal position.
3. Move the release lever toward the front of the printer ().
4. Move the bail lever forward. The printer will automatically feed the parked fanfold paper back into position for printing.

NOTE: The printer beeps intermittently if you move the release lever while the paper is loaded.

Tear off function

At the end of printing, use this tear off function to cut off the printed form without advancing blank forms.

1. Press and hold the **ON LINE** button for one second while in the on-line state.
The paper will be fed to the tear off position and the printer goes off-line state.
2. Tear off the printed form with the tear assist edge of the front cover.
3. Press the **ON LINE** button again to go back on-line.
The paper automatically returns to the printing position. (If fine adjustment is needed use the Micro Feed feature.)

LOADING SINGLE SHEETS

This section will take you through the procedures for loading single sheets of paper.

The paper path for cut forms is shown in Figure 3-10.

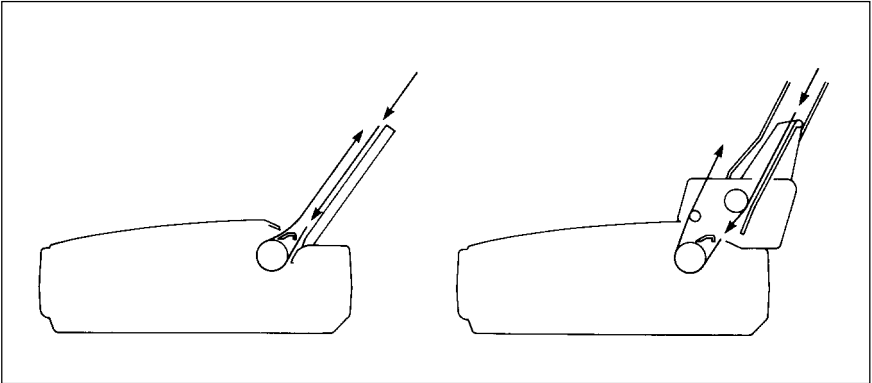

Figure 3-10. Paper path for cut forms.

If you are using the optional Automatic Sheet Feeder, refer to Chapter 7.

1. Raise the paper guide in position on the rear cover of the printer.

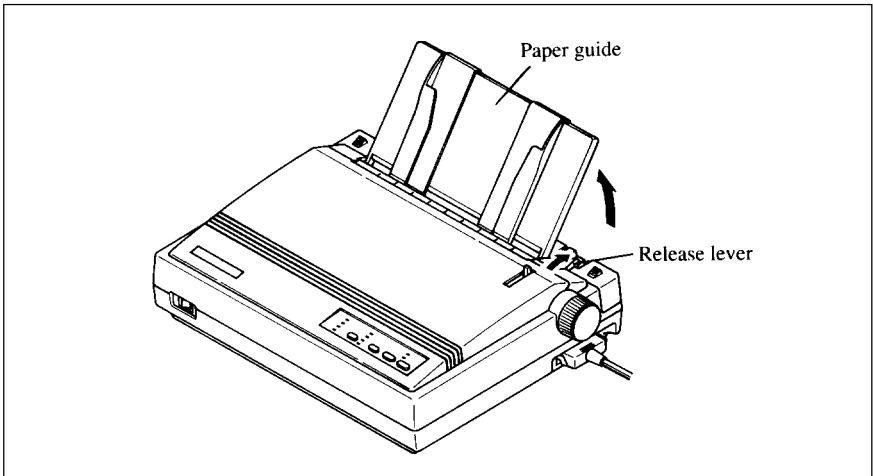



Figure 3-11. Raise the paper guide for single sheets.

2. Adjust the paper guides to match the size of the paper you will be using. Remember that printing will start some distance from the left-hand edge of the carriage.

3. Turn on the power using the switch located at the front of the printer. The printer will beep, indicating that there is no paper in position for printing. The **POWER** indicator will also flash on the control panel to confirm this.
4. Make sure that the release lever is at rear position ().
If fanfold paper is already mounted in the printer, press the **PAPER FEED** button while holding the **FONT** button to park the paper in the off-line state, then move the release lever toward the rear of the printer.
5. Place a single sheet between the guides, placing the side on which you want to print towards the back of the printer. Gently push the paper down in the guides until you feel it stop.
6. Now pull the bail lever toward the front of the printer. The paper will be fed into the printer and adjusted past the print head to a position ready for printing.

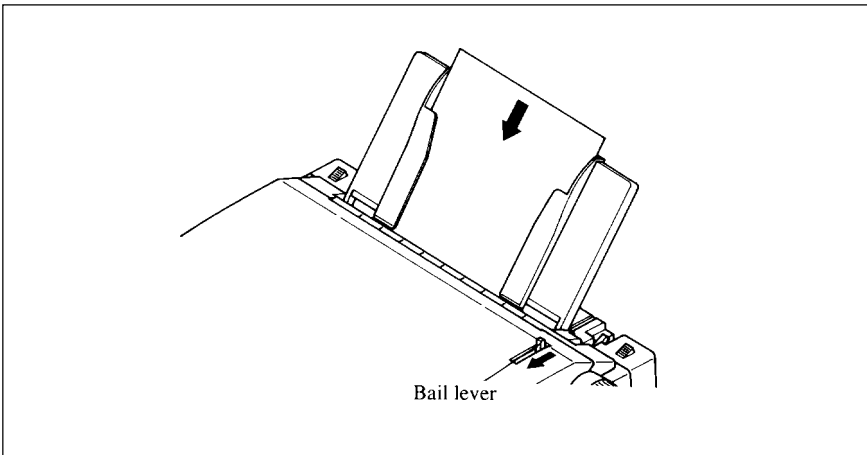

Figure 3-12. Place a single sheet between the guides and pull the bail lever forward.

NOTE: Do not return the bail lever backward before the paper goes through under the bail lever location. The printer indicates with the beep tones to close the bail lever after the paper goes through under the bail lever location.

7. If you want to set the paper to a different position, set the printer off-line by pressing the **ON LINE** button, then set the paper position by using the micro-feed function. (For details, refer to Chapter 4.)

Chapter 4

CONTROL PANEL OPERATIONS

The control panel buttons can be pressed individually to perform the operations indicated by their names. Other functions can be achieved by holding these buttons down when you turn the printer's power on, or by pressing the control panel buttons in combination.

This chapter explains all the button and indicator functions.

- Pause printing
- Feed paper (fast and slow, forward and reverse)
- Park fanfold forms
- Set the top-of-form position
- Select the print pitch
- Select a font
- Print test patterns
- Prevent software from changing the panel pitch and font selections
- Adjusting the print alignment for bi-directional printing
- Print a hexadecimal dump
- Clear the printer's buffer
- Save macro definition

BUTTON AND INDICATOR FUNCTIONS

The printer is equipped with four buttons on the control panel. From left to right they are FONT, PITCH, PAPER FEED and ON LINE.

The following is a brief guide to the buttons and indicators on the control panel.

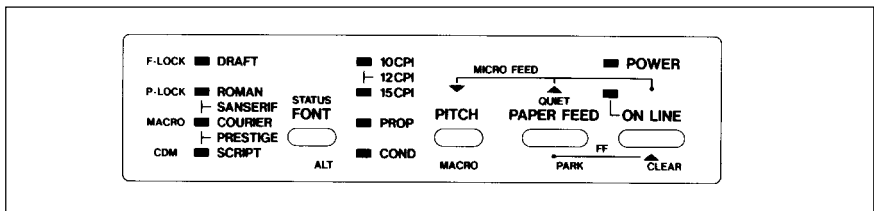

Figure 4-1. Control panel.

ON LINE

The **ON LINE** button sets the printer on-line and off-line. The status changes each time you press the button.

When the printer is on-line, it can receive and print data from the computer and will be indicated by the **ON LINE** indicator being lit. When the printer is off-line, it stops printing and sends the computer a signal indicating that it cannot accept data.

The printer powers up in the on-line status when paper is loaded. If paper is not loaded, the printer powers up off-line with the **POWER** indicator light blinking. When you load paper, the printer goes on-line.

You will want to press the **ON LINE** button:

- Before and after any other panel operation

The other panel buttons operate only in the off-line state. Press the **ON LINE** button to go off-line. After performing the panel operation(s), press the **ON LINE** button again to go back on-line.

- To pause during printing

If you press the **ON LINE** button during printing, the printer stops printing and goes off-line, allowing you to check the printout or change a control panel setting. Printing resumes when you press the **ON LINE** button again to go back on-line.

- To cut fanfold forms at the end of printing

When you hold the **ON LINE** button down for one second with the fanfold forms, the printer goes off-line, then the printer also feeds the paper forward approximately two inches forward. This allows you to cut it off just below the last line printed.

When you press the **ON LINE** button again to go back on-line, the paper feeds backward stopping where you left off.

NOTE: This function is valid only when the buffer is empty.

PAPER FEED

If you press and release this button while off-line, the paper will feed forward one line. If you hold the button down, the printer will perform consecutive line feeds.

If you also press the **ON LINE** button while you are line-feeding, the paper will feed automatically to the top of the next page. This is explained later.

If you press the **PAPER FEED** button while on-line, this will alternately select and cancel the Quiet mode. When in Quiet mode, the printer will print slightly slower, but at a reduced noise level.

PITCH

This button allows you to select the printing pitch. Remember that the printer must be off-line for you to do this. Successive presses of this button will illuminate (and select) the following options in order:

Pitch	Indicator(s)
Pica (10 CPI)	10 CPI
Elite (12 CPI)	10 CPI, 15 CPI
Semi-condensed (15 CPI)	15 CPI
Condensed pica (17 CPI)	10 CPI, COND
Condensed elite (20 CPI)	10 CPI, 15 CPI, COND
Proportional	PROP
Condensed proportional	PROP, COND

FONT

This button selects the font to be printed. Draft font is selected at power-up unless the default settings are changed. To change the font, set the printer off-line, then press the **FONT** button repeatedly until the indicators beside the desired selection illuminate. The selections cycle in the following order:

Font	Indicator(s)
Draft	DRAFT
Roman	ROMAN
Sanserif	ROMAN, COUROER
Courier	COURIER
Prestige	COURIER, SCRIPT
Script	SCRIPT

When this switch is pressed in on-line, the printer indicates the current status as shown below:

Status	Indicator
Font lock mode	DRAFT
Pitch lock mode	ROMAN
Macro definition	COURIER
Compressed Data mode	SCRIPT

POWER-UP FUNCTIONS

In addition to their normal functions, all of the control panel buttons perform “special” functions if you hold them down while switching the power button on.

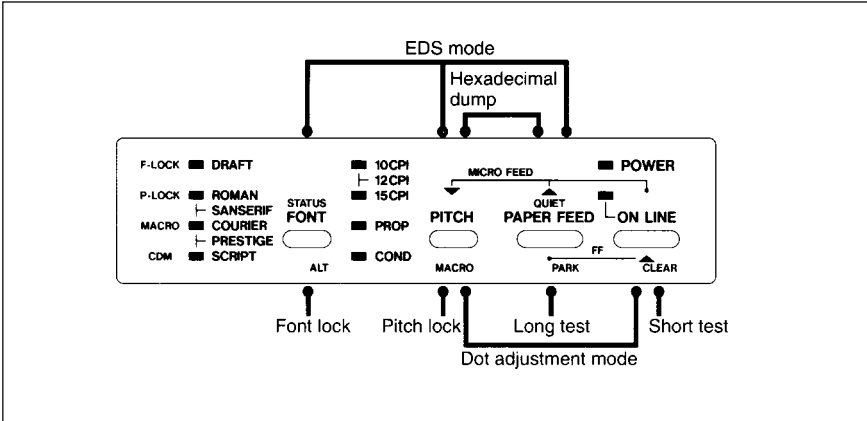

Figure 4-2. Power-up functions of control panel.

Short test mode

If the printer is turned on while the ON LINE button is pressed, the printer will enter the short self-test mode. The printer will print the version number of the printer’s ROM, followed by seven lines of the character set.

Each line will be offset by one character from the one before it. The final result will be something like Figure 4-3.

```

*** Ver X.X ***

! " # $ % & ' ( ) * + , - . / 0 1 2 3 4 5 6 7 8 9 ; < = > ? @ A B C D E F G H I J K L M N O P Q R S T U V W X Y Z [ \ ] ^ _ ` a b c d e f g h i j k l m n o
! " # $ % & ' ( ) * + , - . / 0 1 2 3 4 5 6 7 8 9 ; < = > ? @ A B C D E F G H I J K L M N O P Q R S T U V W X Y Z [ \ ] ^ _ ` a b c d e f g h i j k l m n o p
! " # $ % & ' ( ) * + , - . / 0 1 2 3 4 5 6 7 8 9 ; < = > ? @ A B C D E F G H I J K L M N O P Q R S T U V W X Y Z [ \ ] ^ _ ` a b c d e f g h i j k l m n o p q
# $ % & ' ( ) * + , - . / 0 1 2 3 4 5 6 7 8 9 ; < = > ? @ A B C D E F G H I J K L M N O P Q R S T U V W X Y Z [ \ ] ^ _ ` a b c d e f g h i j k l m n o p q r
$ % & ' ( ) * + , - . / 0 1 2 3 4 5 6 7 8 9 ; < = > ? @ A B C D E F G H I J K L M N O P Q R S T U V W X Y Z [ \ ] ^ _ ` a b c d e f g h i j k l m n o p q r s
% & ' ( ) * + , - . / 0 1 2 3 4 5 6 7 8 9 ; < = > ? @ A B C D E F G H I J K L M N O P Q R S T U V W X Y Z [ \ ] ^ _ ` a b c d e f g h i j k l m n o p q r s t
& ' ( ) * + , - . / 0 1 2 3 4 5 6 7 8 9 ; < = > ? @ A B C D E F G H I J K L M N O P Q R S T U V W X Y Z [ \ ] ^ _ ` a b c d e f g h i j k l m n o p q r s t u

```

Figure 4-3. Short self-test.

Since the self-test prints across the full width of the carriage, it is recommended that the printer is loaded with the widest paper possible to avoid damage to the print head and/or platen.

Hexadecimal dump

This feature is useful for programmers who are debugging printing programs and want to see the actual codes the printer is receiving. (Some computers change the codes the programmer intended.)

In this mode, all data received will be printed in a hexadecimal dump format, rather than the control codes being acted on as command codes.

This mode is accessed with the following procedure:

1. While holding both the **PITCH** and **PAPER FEED** buttons down, turn power **ON**. A beep tone will be heard.
2. Begin printing. In place of the usual printout you will get a formatted dump showing exactly what data the printer receives. Each line presents sixteen characters, their hexadecimal codes to the left and printable characters printed on the right.
3. At the end of the hexadecimal dump, set the printer off-line with the **ON LINE** button. This is necessary to print the last line.

SWITCH COMBINATION FUNCTIONS

Several additional functions can be achieved by pressing the control panel buttons in combinations.

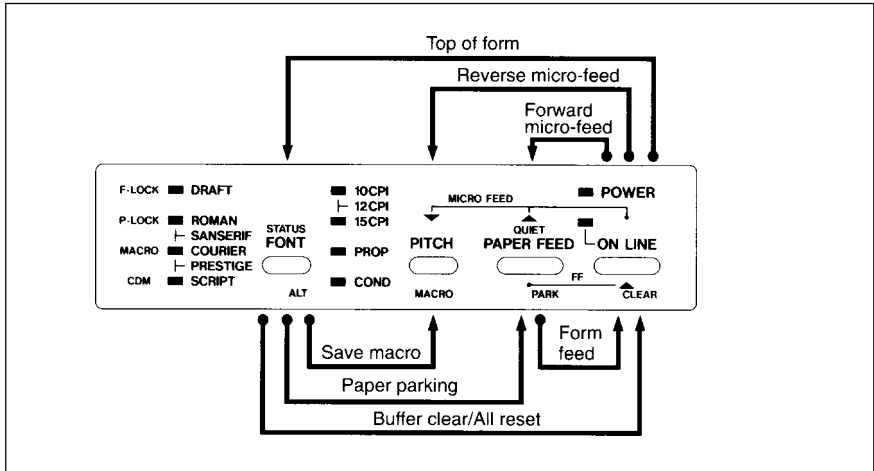

Figure 4-5. Switch combination functions of control panel.

Form feed

If you are using cut forms, this operation ejects the current page. If you are using fanfold forms, it feeds to the top of the next page.

1. Press the ON LINE button to set the printer off-line.
2. Press the PAPER FEED button and hold it down. The printer will start performing successive line feeds.
3. While holding the PAPER FEED button down, press the ON LINE button, then release both buttons at the same time. The printer will smoothly eject the current page.

Paper parking

This procedure feeds the paper backward. It parks the fanfold form at the back of the printer so that you can switch to single-sheet feeding (by moving the release lever to the down position).

Before parking fanfold forms, tear off all but the last page, leaving less (at least three inches less) than a full page showing above the front cover.

1. Press the **ON LINE** button to set the printer off-line.
2. Press the **FONT** button and hold it down.
3. While holding the **FONT** button down, press the **PAPER FEED** button.
The paper will be fed out backward.

Top of form

When you power on the printer, the top-of-form position is automatically set to the current position. If this is not where you want the top of the page to be, you can change the top-of-form position as follows:

1. Press the **ON LINE** button to set the printer off-line.
2. Move the paper to the desired top-of-form position by pressing the **PAPER FEED** button.
3. Press and hold the **ON LINE** button.
4. While holding the **ON LINE** button down, press the **FONT** button, then release both buttons at the same time. The top-of-form position has been set.

Forward micro-feed

For fine alignment, you can feed the paper forward in very small increments as follows:

1. Press the **ON LINE** button to set the printer off-line.
2. Press the **ON LINE** button again and hold it down.
3. While holding the **ON LINE** button down, press the **PAPER FEED** button. The paper will start advancing in a series of small steps.
When you want to stop, release both buttons.

Reverse micro-feed

You can also feed the paper in small increments in reverse, to return to a higher position on the same page.

1. Press the **ON LINE** button to set the printer off-line.
2. Press the **ON LINE** button again and hold it down.
3. While holding the **ON LINE** button down, press the **PITCH** button. The paper will start moving backwards in a series of small steps.
When you want to stop, release both buttons.

NOTE: Open the bail lever when the printer beeps intermittently near the edge of the paper.

Changing the auto loading position

Normally, the printer automatically loads the paper to the desired position according to the setting of EDS switch B-5.

If you want to change this value, follow this procedure:

1. Load the paper by moving bail lever toward the front of the printer.
2. Change the print position using the micro feed function.
3. After you get the desired position, press the **ON LINE** button to save the value.

This position will remain unless you power off the printer. If you want to retain this position even after you turn off the power, store it using the Macro Definition function, which is described later.

Note that you can only change this value immediately after loading paper. If you feed paper, you cannot change the auto loading value.

Clearing the buffer/All reset

The printer stores received data in a large memory buffer. This creates a problem when you want to abandon a printing job and restart: the printer may be holding more data in its buffer than it has actually printed, and this unprinted data must be cleared out before restarting. Turning power off is one way to clear the buffer, but there is another way:

1. Halt the printing program on the computer. If printing stops immediately, the buffer is clear and the rest of this procedure is unnecessary. If printing does not stop, continue as follows:
2. Press the **ON LINE** button to set the printer off-line. Printing will now stop, but there may be data remaining in the buffer.
3. Press and hold the **FONT** button.
4. While pressing the **FONT** button down, press and hold the **ON LINE** button. Continue holding these two buttons down, you will hear a beep tone that the buffer is cleared. If you hold these buttons down longer, you will hear three beep tones and the printer has been initialized to the power-on default settings.
5. Release these buttons, make any necessary control panel settings, then set the printer back on-line.

It is essential to stop the printing program on the computer before you go off-line. Otherwise, when you go back on-line the computer will start sending data again and the printer will continue printing, with missing data from when the buffer was cleared.

Save Macro Definition

You can save the current settings to the printer for later use with the following procedure:

1. Press the **ON LINE** button to set the printer off-line.
2. Press the **FONT** button and hold it down.
3. While holding the **FONT** button down, press the **PITCH** button and hold them down.
4. Release both buttons at the same time after two beep tones to save the current setting. If you release these buttons after three beep tones, the macro has been cleared.

NOTE: You can store the following settings with this procedure.

- Current Font
- Current Pitch
- Current auto-loading amount for cut forms
- Current auto-loading amount for fanfold forms
- Current auto-loading amount in ASF mode

CONDITIONS INDICATED BY BEEP TONES

This section helps you identify the meanings of beep tones.

Beep tones	Meanings
Two seconds tone	Printer detects an error condition. Turn off the power switch and turn it on again.
Long tone, once	Printer detects an error condition. Turn off the power switch and turn it on again.
Two long tone sequence, two times	Bail lever is closed before the paper goes through the location of the bail lever. Open the bail lever to pass the paper under the bail lever.
Four short tone sequence, two times	Printer is out of paper.
Short tone, once	<ul style="list-style-type: none"> • Buffer is cleared. • Top of form is set. • Quiet mode is selected. • EDS mode is selected.
Short tone, twice	<ul style="list-style-type: none"> • Macro definition is selected. • Quiet mode is cancelled.
Short tone, triple	<ul style="list-style-type: none"> • Macro definition is cancelled. • Printer is reset.
One-quarter tone	<ul style="list-style-type: none"> • Hexadecimal mode is selected. • Pitch lock mode is selected. • Font lock mode is selected.
One-quarter tone, twice	Pitch and Font lock mode is selected at a time.
Intermittent tone	Release lever is moved while the paper is in printing position.

MEMO

Chapter 5

DEFAULT SETTINGS-EDS MODE

From the control panel you can change the parameters that define how your printer works. These parameters become your power-on settings. This function is called the Electronic DIP Switch (EDS) mode.

HOW TO SET THE EDS MODE

The EDS mode in this printer has 13 functions that you can set as the power-on default.

Turn the printer on while simultaneously holding the FONT, PITCH, and PAPER FEED buttons. You will hear an acknowledging beep as power comes on. This indicates that you have entered the EDS mode.

In EDS mode, the buttons on the control panel are used as shown below in Figure 5-1.

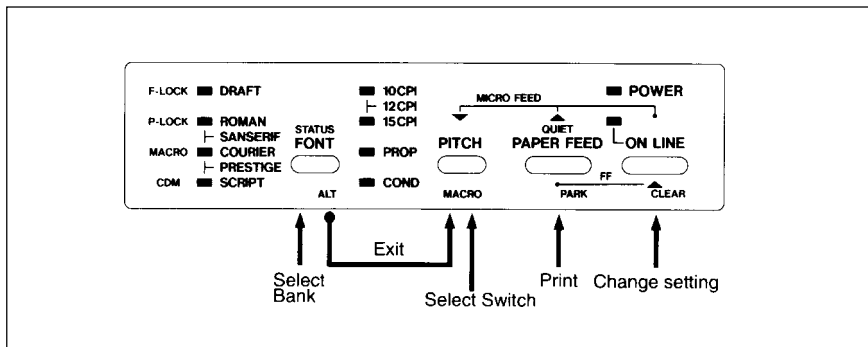

Figure 5-1. Button functions in the EDS mode.

- Use the FONT button to select the Bank Letter.
- Use the PITCH button to select the Switch Number.
- The ON LINE indicator shows the current setting, ON or OFF. Use the ON LINE button to change the settings.
- Press the PAPER FEED button to print the current settings.
- Press the PITCH button while holding down the FONT button to save and exit the EDS mode.

FUNCTIONS OF THE EDS SETTINGS

The printer stores the parameters that you can select from the control panel while in the EDS mode.

A default is the setting that the printer will use if none is specifically selected by a program. When you first turn on or later reset your printer these default settings will take effect.

By changing the settings, you can alter various printer functions to match your specific requirements. The following questions will help you choose the proper settings.

Bank-Switch	Function	ON	OFF
A-1	RAM Usage	(See below)	
A-2			
A-3	Auto LF with CR	Disabled	Enabled
A-4	Automatic Sheet Feeder	Not installed	Installed
A-5	Graphics Direction	Bi-directional	Uni-directional
B-1	(Not used)		
B-2	Paper-out	Enabled	Disabled
B-3	(Not used)		
B-4	(Reserved)	Leave ON	
B-5	Printable Area	Type A	Type B
C-1	Print Mode	(See below)	
C-2			
C-3	Page Length	(See below)	
C-4			
C-5			
D-1	Character Table	Graphics	Italics
D-2	Code page or	(See below)	
D-3	International		
D-4	Character Set		
D-5	CR Centering	Disabled	Enabled
E-1	LQ Font Selection	(See below)	
E-2			
E-3			
E-4	(Reserved)	Leave ON	
E-5	(Reserved)	Leave ON	

NOTE: The factory default is **ON** for all functions except A-5 and B-5 which are set to the **OFF** position.

Switches A-1 and A-2: RAM Usage

These switches determine how to use the RAM memory, as shown below:

A-1	A-2	Download	Input Buffer	Line Buffer
ON	ON	Disabled	7 K-Byte	2 Lines
OFF	ON	Disabled	16 K-Byte	1 Line
OFF	OFF	Enabled	256 Bytes	1 Line

Switch A-3: Auto LF with CR

If you leave this switch at the ON position, a separate line-feed code is required from your computer to obtain a line feed.

If you move this switch to the OFF position, the printer performs both a carriage return and line feed each time it receives a carriage-return code.

Most computer systems send a line feed code, or both a carriage return and line feed, at the end of each line, so this switch should be left ON. If you get double line spacing when you expect single spacing, or if lines overprint each other, try changing the setting of this switch.

Switch A-4: Auto Sheet Feeder

In order to use the optional automatic sheet feeder (SF-10DV), move this switch to the OFF position. Otherwise leave it ON.

Switch A-5: Graphics Direction

When printing in graphics mode, the printer may either print bi-directionally (in alternate directions) for speed or in one direction only (uni-directional for increased accuracy). For practically all purposes, however, bi-directional printing is sufficiently accurate.

Switch B-2: Paper-out

When this switch is OFF the printer ignores the paper-out detector and prints down to (and beyond) the bottom edge.

Switch B-5: Printable area

This printer can use two types of printing area format.

By putting the switch ON (“Type A”), the top of the first line of printing will start 1/6 inch from the top of the paper, and the printed area will end 1/6 inch from the bottom of the paper.

By putting the switch OFF (“Type B”), the first line of printing will start at one inch from the top of the paper, and the printed area will end to print 6 mm from the bottom of the printer.

Switches C-1 and C-2: Print Mode

These switches select the default print pitch and the fonts as shown below.

Print Mode	C-1	C-2
10CPI DRAFT	ON	ON
17CPI DRAFT	OFF	ON
10CPI LQ	OFF	OFF

NOTE: If you change these switches after you have saved a macro, these new settings will override the macro setting.

Switches C-3 to C-5: Page Length

Leave these switches ON if you will be using 11-inch forms. You will need to change the switches if you will be using a different page length as shown below:

Page Length	C-3	C-4	C-5
11 inches/Letter	ON	ON	ON
8 inches	OFF	ON	ON
11.7 inches/A4	ON	OFF	ON
12 inches	OFF	OFF	ON
8.5 inches	ON	ON	OFF
14 inches/Legal	OFF	ON	OFF
10.5 inches/Executive	ON	OFF	OFF
7.25 inches	OFF	OFF	OFF

Switch D-1: Character Table

Move this switch OFF to select Italic character table. If you leave this switch to the ON position, in place of italics you will get the graphic characters, international characters, and mathematical symbols.

Switches D-2 to D-4: Code Page or International Character Set

When the EDS switch D-1 is set ON, these switches select the default character code page as shown below:

Code Page	D-2	D-3	D-4
#437 U.S.A.	ON	ON	ON
#850 Multi-lingual	OFF	ON	ON
#860 Portuguese	ON	OFF	ON
#861 Icelandic	OFF	OFF	ON
#863 Canadian French	ON	ON	OFF
#865 Nordic	OFF	ON	OFF

International character sets differ in their assignment of 14 character codes in the Italic character set. See the character tables in Chapter 11. With these switches you can select one of eight character sets as follows:

Country	D-2	D-3	D-4
U.S.A.	ON	ON	ON
France	OFF	ON	ON
Germany	ON	OFF	ON
England	OFF	OFF	ON
Denmark I	ON	ON	OFF
Sweden	OFF	ON	OFF
Italy	ON	OFF	OFF
Spain I	OFF	OFF	OFF

Switch D-5: CR Centering

If you set this switch OFF, the carriage moves to the center each time to feed paper near the perforation. This way, you can get better quality of printing around the perforations. It is recommended to match the page length setting to your fanfold paper, otherwise, this function does not work properly at the perforations.

If you leave this switch ON, the carriage does not move when feeding paper.

Switches E-1 to E-3: LQ Font Selection

These switches allows you to choose the default font selected when LQ mode is selected, as shown below.

Font Name	E-1	E-2	E-3
Roman	ON	ON	ON
Sanserif	OFF	ON	ON
Courier	ON	OFF	ON
Prestige	OFF	OFF	ON
Script	ON	ON	OFF

Chapter 6

TROUBLESHOOTING

This chapter helps you identify printer conditions and problems that you can often correct yourself.

Your printer is a reliable piece of precision machinery, which should not cause you any trouble, provided it is used and treated sensibly. However, the few elementary tips below should help you avoid having to make unnecessary service calls.

Remember that your printer is a highly sophisticated electronic device, which also contains high voltage inside. For that reason, only carry out those operations described in this chapter.

CAUTION: Any attempt to carry out operations other than those described here may result in electric shock and/or damage to the printer. When carrying out any repairs or maintenance, always follow the instructions carefully.

- Power switch is on, but power indicator is off

Check	Possible remedy
Printer is not getting power.	Make sure that the power cord is correctly connected. Verify that the power source works.

- Printer sounds as if it is printing but does not; Printing is weak

Check	Possible remedy
Ribbon is jamming, twisted, or not between the print head and the print head shield.	Make sure that the ribbon cartridge is correctly installed. Make sure that the ribbon is between the shield on the print head and the end of the print head. Replace the ribbon.
Adjustment lever is set incorrectly.	Check the setting of the adjustment lever. Move the lever to a darker setting.

- Printer test works, but printer does not print when attached to computer

Check	Possible remedy
Printer cable has a problem.	Make sure that the printer cable is correctly connected at both ends, printer and computer.
Problem with the application program.	Refer to your application program manual.

- Printer sounds the audible alarm

Check	Possible remedy
This might indicate an error or normal operation.	Check the status of the control panel indicators and see “Conditions indicated by beep tones” in Chapter 4.

- Pitch or font selected is being changed

Check	Possible remedy
Your software is overriding your control panel selection.	Set your printer in Font/Pitch lock. See “Pitch lock mode” and “Font lock mode” in Chapter 4.

- Printer does not feed paper

Check	Possible remedy
Paper is jamming.	Remove all forms and pieces of paper.
Bail lever is closed before paper goes through the bail lever location.	Open the bail lever.
Adjustment lever is set incorrectly.	Check the setting of the adjustment lever. See “Adjusting the printing gap” in Chapter 3.
Fanfold form is parked.	Move bail lever forward to unpark the fanfold paper.

- Line spacing is incorrect or overprinting occurs

Check	Possible remedy
The tractor positions are incorrectly adjusted.	Adjust the tractor positions. See “Loading fanfold forms” in Chapter 3.
Problem with the application program.	Refer to your application program manual.
Platen knob was manually turned while the Power indicator was on.	Set the top of form. See “Top of form” in Chapter 4. Do not manually turn the platen knob when the power is on. Use the PAPER FEED button.
Forms are jamming between printing surface and the print head.	Reset adjustment lever. See “Adjusting the printing gap” in Chapter 3.
Forms are jamming between printing surface and the platen	Clean the surface of the platen roller with a cloth barely dampened with a little alcohol.

- Incorrect number of lines on a page

Check	Possible remedy
Paper is adjusted incorrectly.	Set the top of form. See “Top of form” in Chapter 4.
Paper has shifted backwards after several forms printed correctly.	Readjust forms.
Problem with the application program.	Refer to your application program manual.
Distance printer must pull paper is too far.	Move paper closer to the printer.
Paper is getting stuck on cables.	Move the paper away from any wires or cables.

- Line length is wrong; Graphics do not print; Lines are not starting at left margin

Check	Possible remedy
Problem with the application program.	Refer to your application program manual.

- Characters are wrong or missing; formatting control codes do not work

Check	Possible remedy
Problem with the application program.	Refer to your application program manual.
Some wires are missing from the print head.	Printer needs repair.
Wrong default setting with EDS switches.	Check the current EDS setting. Modify the EDS setting.

- Dots are missing or print quality is poor

Check	Possible remedy
Adjustment lever is set incorrectly.	Check the position of the adjustment lever. See Chapter 3.
Print head is not working.	Printer needs repair.

- Forms are smudged or printing is too dark

Check	Possible remedy
Adjustment lever is set incorrectly.	Check the position of the adjustment lever. Move the lever to a lighter setting (front). See Chapter 3.
Ribbon is twisted or is not between the print head and the print head shield.	Install the ribbon correctly. See “Installing the ribbon cartridge” in Chapter 2.
Print head shield (or print head) is damaged or missing.	See “Installing the ribbon cartridge” in Chapter 2 to locate the print head shield and print head. Contact your dealer.

- Printer is unstable; Wrong characters are printed; Left margin changes; Printing stops

Check	Possible remedy
Static electricity is resulting from low humidity or interference from nearby electrical devices.	Increase the humidity. Move devices with electric motors away from the printer.

- Left margin moves to the right during printing

Check	Possible remedy
The print head is not moving correctly.	Check that the ribbon and paper are correctly installed. See “Installing ribbon cartridge” in Chapter 2 and “Loading paper” in Chapter 3.
Problem with the application program.	Refer to your application program manual.
The adjustment lever is in the wrong position.	Reset the adjustment lever. See “Adjusting the printing gap” in Chapter 3.

- Printer is printing beyond side edge of forms

Check	Possible remedy
Paper is adjusted incorrectly.	Adjust both forms tractors and the paper.
Problem with the application program.	Refer to your application program manual.
A print head jam caused by the ribbon or a paper jam.	Make sure that the ribbon cartridge is correctly installed. See “Installing the ribbon cartridge” in Chapter 2. Clear the paper jam.

- Printer case is hot to the touch

Check	Possible remedy
Printer’s vents are blocked.	Move object away from the air vents, including the bottom of the printer.

- Printer is noisy

Check	Possible remedy
The printer vibrates.	Move any objects that touch the printer. Ensure that the printer is on a level, sturdy surface.
Printer covers are open.	Close covers.

MAINTENANCE

Essentially, your printer is a robust piece of equipment, but should be treated with a modicum of care in order to avoid malfunctions. For example:

- Keep your printer in a “comfortable” environment. Roughly speaking, if you are comfortable, then the environment is suitable for your printer (see Chapter 2).
- Do not subject the printer to physical shocks or excessive vibration.
- Avoid over-dusty environments. Dust is the enemy of all precision mechanical devices.
- To clean the exterior of the printer, use a cloth barely dampened with either water with a little detergent or a little alcohol, but do not allow any liquid to fall inside the printer.
- The interior of the printer may be cleaned with a small cleaner or a compressed-air aerosol (sold for this purpose). When performing this operation, be sure not to bend or damage any cable connections or electronic components.

Chapter 7

OPTIONAL ACCESSORIES

You can select the following accessories as option.

- Automatic sheet feeder (SF-10DV)
- Serial-Parallel Converter (SPC-8K)

This chapter describes how to install and use these optional accessories.

NOTE: When you install or remove the optional accessories, turn off the power switch.

AUTOMATIC SHEET FEEDER (SF-10DV)

You can use the Automatic Sheet Feeder (ASF) to print on cut-sheet forms.

Before install the ASF, check each item in the box against Figure 7-1 to make sure that you have everything.

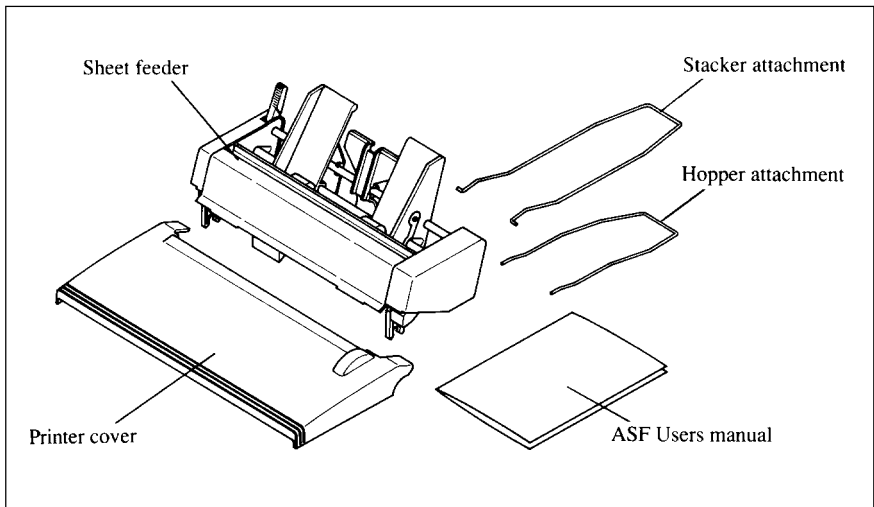

Figure 7-1. Check to make sure you have all five items: 1) Sheet Feeder, 2) Hopper attachment, 3) Stacker attachment, 4) Printer cover, and 5) ASF Users manual.

NOTE: The Automatic Sheet Feeder is protected by packing and tape during shipping. Be sure to remove all of the protective material and tape before use.

Setting up

The procedure to install the ASF is:

1. Use the printer's EDS mode to select ASF as "installed". (For details, please refer to Chapter 5.)
2. Open the front cover by lifting up the back using the two grips on either side, then remove the cover by pulling up.
3. Move the printer bail lever toward the front of the printer to open the paper bail.

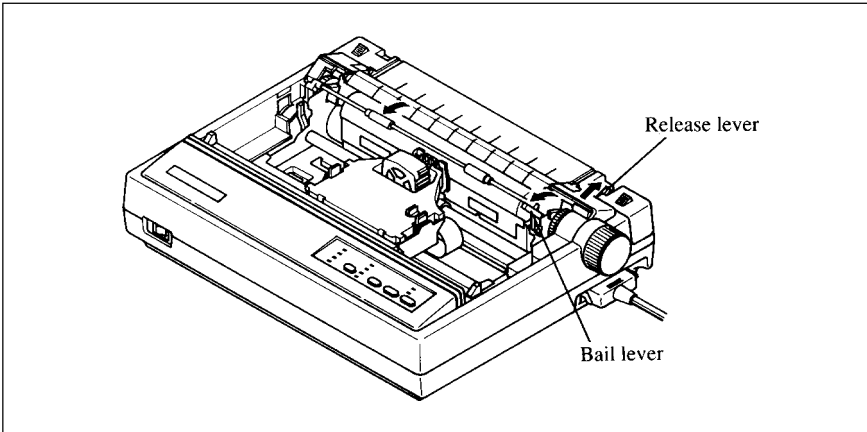

Figure 7-2. Remove the front cover, and move the bail lever toward the front of the printer.

4. Secure the mounting brackets of the Automatic Sheet Feeder onto the shaft of the platen by lowering it into position as shown in Figure 7-3.

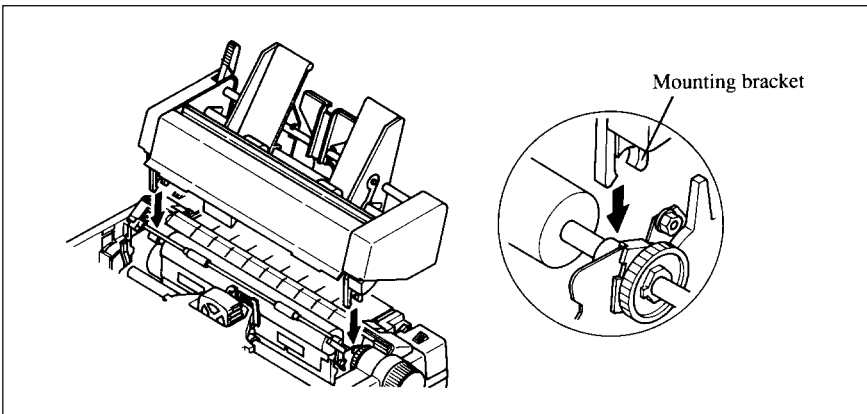

Figure 7-3. Mount the Automatic Sheet Feeder onto the printer.

5. Confirm that the mounting brackets on both sides of the Automatic Sheet Feeder are correctly engaged on the printer. When they are engaged correctly, the ejection roller can be rotated by turning the platen knob.
6. Install the printer cover provided with the Automatic Sheet Feeder.

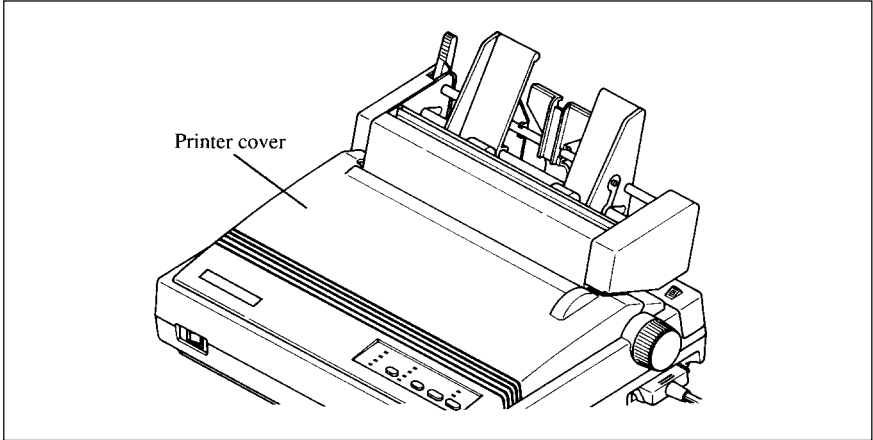

Figure 7-4. Install the printer cover.

7. Insert the hopper attachment on top of the hopper support section as shown in Figure 7-5.

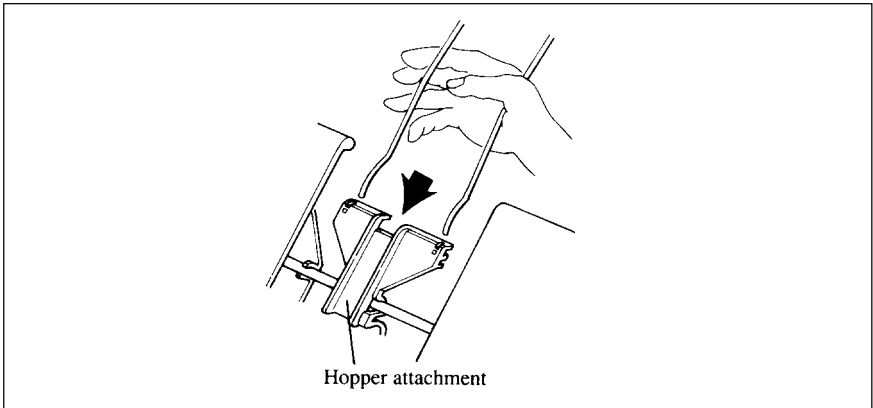

Figure 7-5. Insert the hopper attachment.

8. Insert the stacker attachment, squeezing it with your hand, into the fixing groove in the front part of the sheet feeder as shown in Figure 7-6.

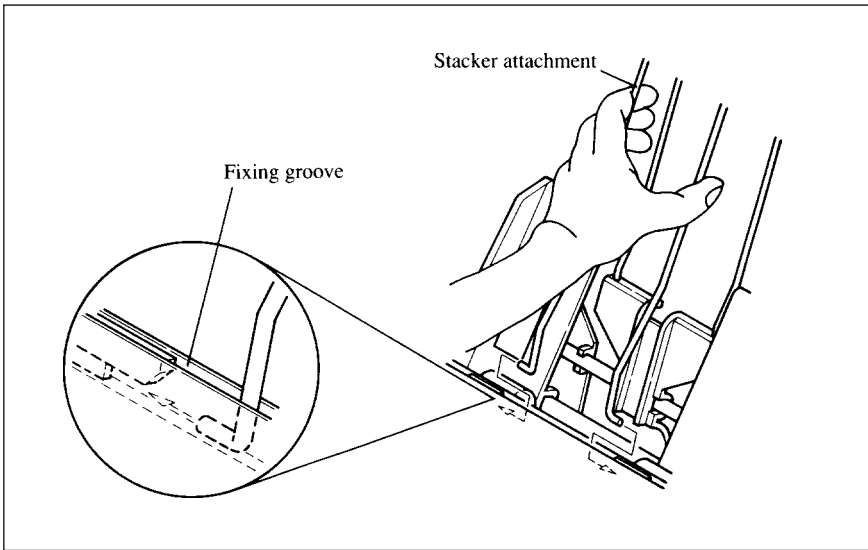



Figure 7-6. Insert the stacker attachment.

Now, you can use the ASF by installing the paper stack into the hopper.

NOTE: Set the front cover and paper guide aside carefully after they have been removed from the printer. Reverse the procedure described above when removing the Automatic Sheet Feeder.

Loading paper

1. If fanfold paper has already been loaded in the printer, park the paper through the rear slot.
2. Push the printer release lever toward the rear of the printer () to load single sheets.
3. Pull the paper loading lever toward the front of the printer to pull the hopper out until it is in position.

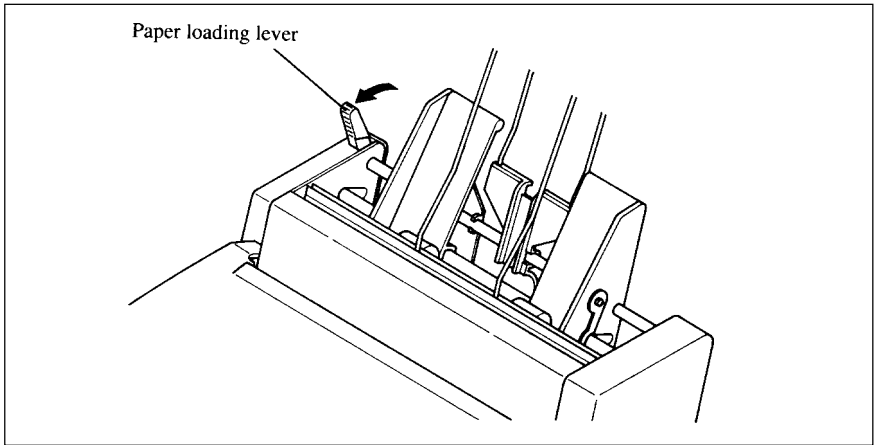

Figure 7-7. Pull the paper loading lever forward.

4. Adjust the left paper guide to the desired left position by moving it horizontally in either direction.

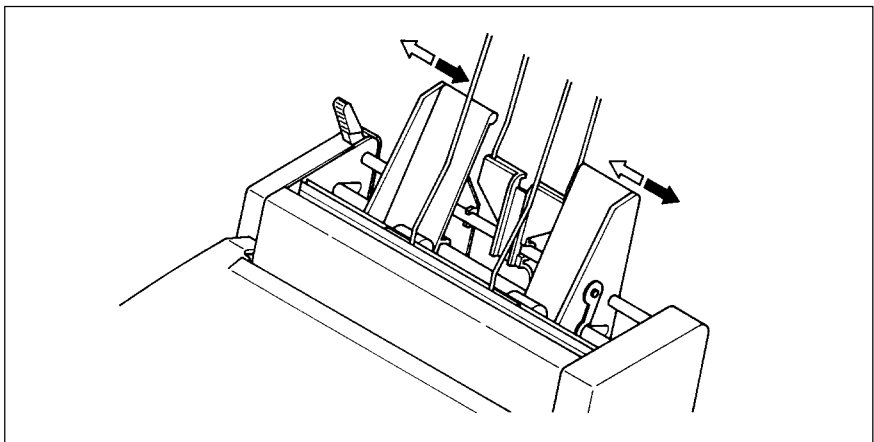

Figure 7-8. Adjust the paper guides to accommodate the width of the paper.

5. Fan the paper stack and square it off properly before inserting it into the Automatic Sheet Feeder.

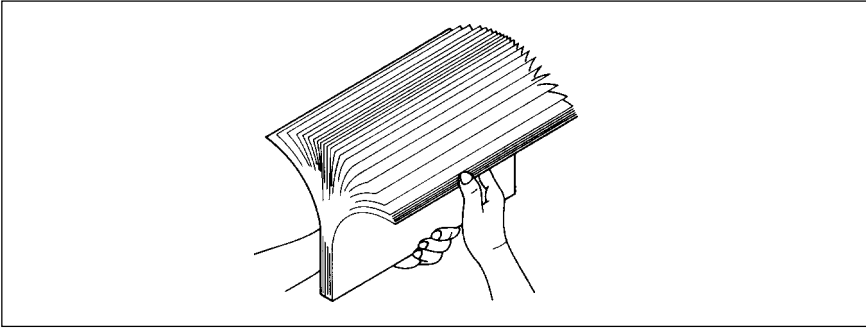

Figure 7-9. Fan the paper before inserting into the ASF.

6. Insert the paper stack into the Automatic Sheet Feeder.
The stack should not be more than 50 sheets of 20 lb paper.
If necessary, remove some sheets. The ASF may not perform satisfactorily if it is overloaded.
7. Adjust the right paper guide to accommodate the width of the paper.
The guides should be adjusted to restrict the amount of horizontal play while allowing the paper to slide up and down freely between the two paper guides. The ideal distance between paper ream and paper guides is 0.25 mm (0.01 ") on both sides at the narrowest part of the paper guides.
8. Push the paper loading lever toward the rear of the printer.

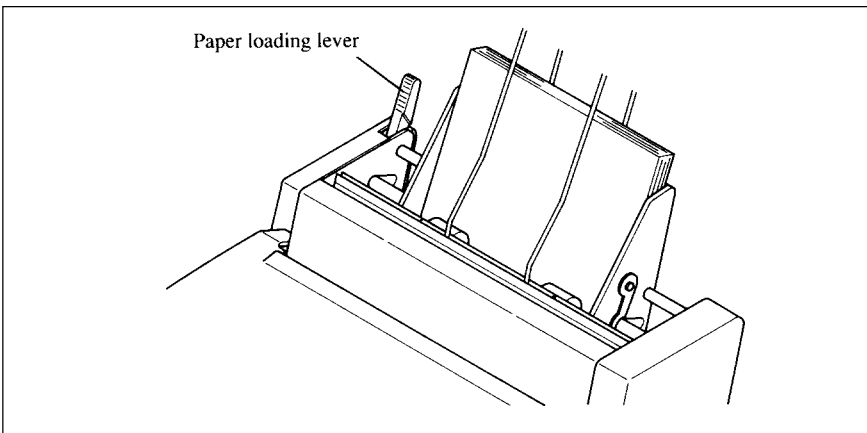

Figure 7-10. Push the paper loading lever to hold the paper stack.

Now, you are ready to start printing with the Automatic Sheet Feeder.

INTERFACE CONVERTER

To run the printer in serial mode, you should use the optional Serial/Parallel Converter, SPC-8K.

The procedure to install the Converter is:

1. Set the DIP switches on the SPC-8K before attaching it to the printer. (See next page for detailed information.)
2. Turn off the power switch and disconnect the power cord from the power source.
3. Disconnect the interface cable if attached.
4. Connect the Parallel connector to the printer.
5. Move both clips inside the extended prongs on the sides of the plug until you hear a click.

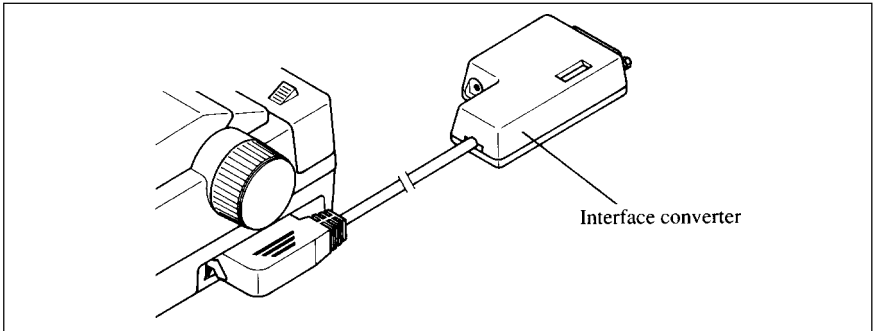

Figure 7-11. Connect the Parallel connector to the printer.

6. Connect the Serial connector to your computer.

NOTE: Place the Converter on a table in order not to damage the cable.

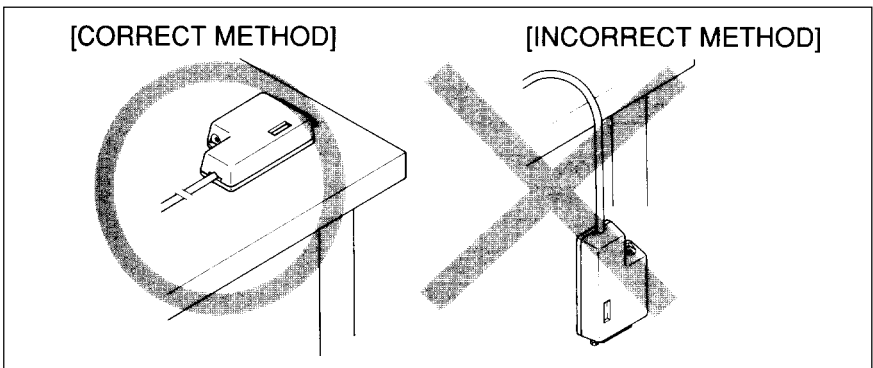

Figure 7-12. Place the converter on a table.

DIP switch functions on the converter

It is necessary to make compatible the data transfer conditions between the computer and the serial interface board with the DIP switch settings on the converter.

Following table shows the functions of the DIP switches on the Serial-Parallel Converter.

Switch	Function	ON	OFF
1	Data length	8-bit	7-bit
2	Parity condition	(Refer below)	
3	Data Protocol	(Refer below)	
4			
5	Parity condition	(Refer below)	
6	Transfer speed	(Refer below)	
7			
8			

[Parity condition]

Switch 2	Switch 5	Condition
ON	ON	No parity
ON	OFF	
OFF	ON	Odd parity
OFF	OFF	Even parity

[Data protocol]

Switch 3	Switch 4	Protocol
ON	ON	DTR
ON	OFF	XON/XOFF
OFF	ON	ETX/ACK

[Transfer speed]

Switch 6	Switch 7	Switch 8	Transfer speed
OFF	OFF	OFF	150 BPS
OFF	OFF	ON	300 BPS
OFF	ON	OFF	600 BPS
OFF	ON	ON	1200 BPS
ON	OFF	OFF	2400 BPS
ON	OFF	ON	4800 BPS
ON	ON	OFF	9600 BPS
ON	ON	ON	19200 BPS

Chapter 8

PRINTER CONTROL COMMANDS

This printer emulates the functions of the Epson LQ-860/850, and the graphics commands for NEC 24-wire printers. Additional command codes are included as a superset of this emulation.

This chapter describes the printer's control commands. In the descriptions of the commands, all commands will given by functions. The name of each command is followed by a table like the one below:

ASCII	Decimal	Hexadecimal
<ESC> "x" <1>	27 120 1	1B 78 01

ASCII: Indicates the ASCII coding of the command. Control characters are enclosed in pointed brackets: For example, <1> means character code 1.

Decimal: Gives the command in decimal character codes.

Hexadecimal: Gives the command in hexadecimal character codes.

Parameters for which values must be supplied are indicated by italic letters such as *n*, *m* or *d*.

FONT CONTROL COMMANDS

Select print quality

ASCII	Decimal	Hexadecimal
<ESC> “x” <i>n</i>	27 120 <i>n</i>	1B 78 <i>n</i>

Changes the print quality according to the value of *n*, as shown below:

<i>n</i>	Print quality
0	Draft
1	Letter quality

Ignored if the **FONT LOCK** mode was selected during power-up.

Select LQ font

ASCII	Decimal	Hexadecimal
<ESC> “k” <i>n</i>	27 107 <i>n</i>	1B 6B <i>n</i>

Selects an LQ font according to the value of *n*. In draft mode, this command remains dormant and takes effect later when LQ is selected. Ignored if the **FONT LOCK** mode was selected during power-up.

<i>n</i>	Font
0	Roman
1	Sanserif
2	Courier
3	Prestige
4	Script

Select italic characters

ASCII	Decimal	Hexadecimal
<ESC> “4”	27 52	1B 34

Causes subsequent characters except block graphics to be printed in italics.

Select upright characters

ASCII	Decimal	Hexadecimal
<ESC> “5”	27 53	1B 35

Stops italic printing and causes subsequent characters to be printed upright.

Emphasized printing

ASCII	Decimal	Hexadecimal
<ESC> “E”	27 69	1B 45

Causes subsequent characters to be emphasized by adding extra thickness to horizontal strokes.

Cancel emphasized printing

ASCII	Decimal	Hexadecimal
<ESC> “F”	27 70	1B 46

Cancels emphasized printing.

Double-strike printing

ASCII	Decimal	Hexadecimal
<ESC> “G”	27 71	1B 47

Causes subsequent characters to be printed in double-strike mode with a slight vertical paper motion in between, causing a thickening of vertical strokes.

For bold print, use of double-strike is recommended in LQ mode, and combined use of emphasized and double-strike is recommended in draft mode.

Cancel double-strike printing

ASCII	Decimal	Hexadecimal
<ESC> “H”	27 72	1B 48

Cancels double-strike printing.

Underlining

ASCII	Decimal	Hexadecimal
<ESC> “-” <i>n</i>	27 45 <i>n</i>	1B 2D <i>n</i>

Causes subsequent characters to be underlined when *n* is 1, and stops underlining when *n* is 0. Block graphics characters and spaces skipped by horizontal tabulation are not underlined.

Select score

ASCII	Decimal	Hexadecimal
<ESC> “(” “-” <3> <0> <1> <i>n1 n2</i>	27 40 45 3 0 1 <i>n1 n2</i>	1B 28 2D 03 00 01 <i>n1 n2</i>

Start score according to the values of *n1* and *n2*, as shown below.

<i>n1</i>	Function	<i>n2</i>	Function
1	Underlining	0	Cancel score
2	Strike-through	1	Single continuous line
3	Overlining	2	Double continuous line
		5	Single broken line
		6	Double broken line

Select ornament chracter

ASCII	Decimal	Hexadecimal
<ESC> “q” <i>n</i>	27 113 <i>n</i>	1B 71 <i>n</i>

Selects an ornament character according to the value of *n*, as shown below.

<i>n</i>	Character
0	Normal
1	Outline
2	Shadow
3	Shadow and outline

Superscript

ASCII	Decimal	Hexadecimal
<ESC> "S" <0>	27 83 0	1B 53 00

Causes subsequent characters to be printed as superscripts. Does not change the character pitch.

Subscript

ASCII	Decimal	Hexadecimal
<ESC> "S" <1>	27 83 1	1B 53 01

Causes subsequent characters to be printed as subscripts. Does not change the character pitch.

Cancel superscript or subscript

ASCII	Decimal	Hexadecimal
<ESC> "T"	27 84	1B 54

Stops printing superscripts or subscripts and returns to normal printing.

CHARACTER SET COMMANDS

Assign character set

ASCII	Decimal	Hexadecimal
<ESC> “(” “t” <3> <0> <i>n1 n2 <0></i>	27 40 116 3 0 <i>n1 n2 0</i>	1B 28 74 03 00 <i>n1 n2 00</i>

Assigns the character set, defined with the value of *n2*, to the character table *n1* (where *n1* is between 0 and 3) as shown below:

<i>n2</i>	Character set
0	Italic
1	Code Page #437 U.S.A.
3	Code Page #850 Multi-lingual
7	Code Page #860 Portuguese
8	Code Page #863 Canadian French
9	Code Page #865 Nordic

Characters assigned to tables 0 and 1 with this command are not cleared by the reset command, <ESC> “@”.

Select character table

ASCII	Decimal	Hexadecimal
<ESC> “(” <i>n1</i>	27 116 <i>n1</i>	1B 74 <i>n1</i>

Selects a character table defined by the last preceding <ESC> “(” “(” “t” command.

If there is no preceding <ESC> “(” “(” “t” command, following character tables are selected.

<i>n1</i>	Character table
0	Italic
1	Code Page #437 U.S.A.
2	Shift download character area
3	Code Page #437 U.S.A.

Select Italic character set

ASCII	Decimal	Hexadecimal
<FS> “I” <0>	28 73 0	1C 49 00

Selects the Italic character set. This is the power-up default if EDS switch D-1 is set to OFF.

Select Graphics character set

ASCII	Decimal	Hexadecimal
<FS> "I" <I>	28 73 1	1C 49 01

Selects the Graphics character set. This is the power-up default if EDS switch D-1 is set to ON.

Select character set #1

ASCII	Decimal	Hexadecimal
<ESC> "7"	27 55	1B 37

Selects character set #1.

Select character set #2

ASCII	Decimal	Hexadecimal
<ESC> "6"	27 54	1B 36

Selects character set #2.

Select international character set

ASCII	Decimal	Hexadecimal
<ESC> "R" <i>n</i>	27 82 <i>n</i>	1B 52 <i>n</i>

Selects an international character set in the Italic character set according to the value of *n*.

<i>n</i>	Character set	<i>n</i>	Character set
0	U.S.A	8	Japan
1	France	9	Norway
2	Germany	10	Denmark II
3	England	11	Spain II
4	Denmark I	12	Latin America
5	Sweden	13	Korea
6	Italy	14	Irish
7	Spain I	64	Legal

The first eight of these character sets (from U.S.A. to Spain I) can be selected as power-up default by EDS switches D-2 to D-4.

CHARACTER SIZE AND PITCH COMMANDS

Pica pitch

ASCII	Decimal	Hexadecimal
<ESC> “P”	27 80	1B 50

Changes from either elite or semi-condensed to pica pitch (10 cpi) or from condensed elite to condensed pica (17 cpi). Ignored if the **PITCH LOCK** mode was selected during power-up.

Elite pitch

ASCII	Decimal	Hexadecimal
<ESC> “M”	27 77	1B 4D

Changes from either pica or semi-condensed to elite pitch (12 cpi) or from condensed pica to condensed elite (20 cpi). Ignored if the **PITCH LOCK** mode was selected during power-up.

Semi-condensed pitch

ASCII	Decimal	Hexadecimal
<ESC> “g”	27 103	1B 67

Changes from either pica or elite to semi-condensed pitch (15 cpi). Ignored if the **PITCH LOCK** mode was selected during power-up.

Condensed printing

ASCII	Decimal	Hexadecimal
<SI>	15	0F
<ESC> <SI>	27 15	1B 0F

Changes from pica to condensed pica (17 cpi) or from elite to condensed elite (20 cpi). Ignored if the **PITCH LOCK** mode was selected during power-up.

Cancel condensed printing

ASCII	Decimal	Hexadecimal
<DC2>	18	12

Changes from condensed pica to normal pica or from condensed elite to normal elite. Ignored if the **PITCH LOCK** mode was selected during power-up.

Proportional spacing

ASCII	Decimal	Hexadecimal
<ESC> “p” <i>n</i>	27 112 <i>n</i>	1B 70 <i>n</i>

Causes subsequent characters to be proportionally spaced when *n* is 1, and cancels it when *n* is 0. Ignored if the **PITCH LOCK** mode was selected during power-up.

Expanded printing

ASCII	Decimal	Hexadecimal
<ESC> “W” <i>n</i>	27 87 <i>n</i>	1B 57 <i>n</i>

Causes subsequent characters to be expanded to double width when *n* is 1, and cancels it when *n* is 0.

Expanded printing for one line

ASCII	Decimal	Hexadecimal
<SO>	14	0E
<ESC> <SO>	27 14	1B 0E

Causes subsequent characters in the current line to be expanded to double width. Characters return to normal width after the next line feed (<LF>). The <DC4>, <VT>, <FF>, and <ESC> “W” 0 commands also cancel expanded printing.

Cancel one-line expanded printing

ASCII	Decimal	Hexadecimal
<DC4>	20	14

Stops one-line expanded printing set with <SO> or <ESC> <SO>.
Does not cancel <ESC> “W” 1.

Select character width

ASCII	Decimal	Hexadecimal
<FS> “E” <i>n</i>	28 69 <i>n</i>	1C 45 <i>n</i>

Selects a character width according to the value of *n* as shown below.

<i>n</i>	Character width
0	Normal-wide
1	Double-wide
2	Triple-wide

Select master print mode

ASCII	Decimal	Hexadecimal
<ESC> “!” <i>n</i>	27 33 <i>n</i>	1B 21 <i>n</i>

Selects a combined print mode according to the value of *n*. The value of *n* is the sum of the values given below for the desired characteristics.

Function	<i>n</i> value
Underline	128
Italic	64
Expanded	32
Double strike	16
Emphasized	8
Condensed [*]	4
Proportional [*]	2
Elite [*]	1

[*] Ignored if the **PITCH LOCK** mode was selected during power-up.

Increase character spacing

ASCII	Decimal	Hexadecimal
<ESC> <SP> <i>n</i>	27 32 <i>n</i>	1B 20 <i>n</i>

Increases the space between characters by *n* dots, where *n* is a number from 0 to 127. Used in microjustification.

Print double-height characters

ASCII	Decimal	Hexadecimal
<ESC> “w” <1>	27 119 1	1B 77 01
<FS> “V” <1>	28 86 1	1C 56 01

Prints subsequent characters at double height without moving the base line, and without changing the line spacing.

Return to normal height

ASCII	Decimal	Hexadecimal
<ESC> “w” <0>	27 119 0	1B 77 00
<FS> “V” <0>	28 86 0	1C 56 00

Terminates double-height printing and prints subsequent characters at normal height.

VERTICAL POSITION COMMANDS

Set line spacing to 1/8 inch

ASCII	Decimal	Hexadecimal
<ESC> “0”	27 48	1B 30

Sets the distance the paper advances or reverses in subsequent line feeds to 1/8 inch.

Set line spacing to 1/6 inch

ASCII	Decimal	Hexadecimal
<ESC> “2”	27 50	1B 32

Sets the distance the paper advances or reverses in subsequent line feeds to 1/6 inch.

Set line spacing to $n/360$ inch

ASCII	Decimal	Hexadecimal
<ESC> “+” n	27 43 n	1B 2B n
<FS> “3” n	28 51 n	1C 33 n

Set the distance the paper advances or reverses in subsequent line feeds to $n/360$ inch, where n is between 0 and 255.

Set line spacing to $n/180$ inch

ASCII	Decimal	Hexadecimal
<ESC> “3” n	27 51 n	1B 33 n

Sets the distance the paper advances or reverses in subsequent line feeds to $n/180$ inch.

The value of n is between 0 and 255. If $n = 0$, the line-feed distance is set to 0.

Set line spacing to $n/60$ inch

ASCII	Decimal	Hexadecimal
<ESC> "A" n	27 65 n	1B 41 n

Sets the distance the paper advances or reverses in subsequent line feeds to $n/60$ inch, where n is between 0 and 255. If $n = 0$, the line spacing is set to 0.

Line feed

ASCII	Decimal	Hexadecimal
<LF>	10	0A

Prints the current line and feeds the paper to the next line. See the preceding commands for the line spacing.

Reverse line feed

ASCII	Decimal	Hexadecimal
<ESC> <LF>	27 10	1B 0A

Prints the current line and feeds the paper in the reverse direction to the preceding line.

See the preceding commands for the line spacing.

Select forward feed mode

ASCII	Decimal	Hexadecimal
<FS> "F"	28 70	1C 46

Cancels the reverse feed mode and selects forward feed mode. This is the default setting at power-on.

Select reverse feed mode

ASCII	Decimal	Hexadecimal
<FS> "R"	28 82	1C 52

Selects reverse feed mode. Reverses the direction of all vertical movements. Ignored when friction feed is used.

Perform one n/180-inch line feed

ASCII	Decimal	Hexadecimal
<ESC> “J” <i>n</i>	27 74 <i>n</i>	1B 4A <i>n</i>

Feeds the paper once by $n/180$ inches. The value of n is between 0 and 255. Does not move the print position right or left. Does not change the line-spacing setting.

Perform one n/180-inch reverse line feed

ASCII	Decimal	Hexadecimal
<ESC> “j” <i>n</i>	27 106 <i>n</i>	1B 6A <i>n</i>

Feeds the paper once by $n/180$ inches in the reverse direction, where n is between 0 and 255. Does not move the print position right or left. Does not change the line-spacing setting.

Set page length to n lines

ASCII	Decimal	Hexadecimal
<ESC> “C” <i>n</i>	27 67 <i>n</i>	1B 43 <i>n</i>

Sets the page length to n lines in the current line spacing, where n is between 1 and 127.
Changing the line spacing later does not alter the physical page length.
The current line becomes the top of the page.

Set page length to n inches

ASCII	Decimal	Hexadecimal
<ESC> “C” <0> <i>n</i>	27 67 0 <i>n</i>	1B 43 00 <i>n</i>

Sets the page length to n inches, where n is between 1 and 32. The current line becomes the top of the page.

Set bottom margin

ASCII	Decimal	Hexadecimal
<ESC> “N” <i>n</i>	27 78 <i>n</i>	1B 4E <i>n</i>

Sets the bottom margin to n lines, where n is between 1 and 127. The bottom margin is reset when you change the page length.

Cancel bottom margin

ASCII	Decimal	Hexadecimal
<ESC> "O"	27 79	1B 4F

Cancels the bottom margin.

Form feed

ASCII	Decimal	Hexadecimal
<FF>	12	0C

Feeds the paper to the top of the next page according to the current page length, and moves the print position to the left margin. When the automatic sheet feeder (ASF) is selected with EDS switch A-4, this command ejects the current page.

Set vertical tab stops

ASCII	Decimal	Hexadecimal
<ESC> "B" $n1$ $n2$... <0>	27 66 $n1$ $n2$... 0	1B 42 $n1$ $n2$... 00

Cancels all current vertical tab stops and sets new vertical tab stops at lines $n1$, $n2$, etc., where $n1$, $n2$, etc. are numbers between 1 and 255. A maximum of 16 vertical tab stops can be set. The tab stops must be specified in ascending order; any violation of ascending order terminates the tab stop list. Standard termination is by the <0> control code. The vertical tab stops are set in terms of the current line spacing and do not move if the line spacing is changed later.

Set vertical tab stops in channel

ASCII	Decimal	Hexadecimal
<ESC> "b" $n0$ $n1$ $n2$... <0>	27 98 $n0$ $n1$ $n2$... 0	1B 62 $n0$ $n1$ $n2$... 00

Cancels all current vertical tab stops in channel $n0$, (where $n0$ is between 0 and 7) and sets new vertical tab stops in this channel. (A channel is a set of vertical tab stops selected by the <ESC> "/" command.) See <ESC> "B" for parameters $n1$, $n2$, ... <0>.

Select vertical tab channel

ASCII	Decimal	Hexadecimal
<ESC> “/” <i>n0</i>	27 47 <i>n0</i>	1B 2F <i>n0</i>

Selects a set of vertical tab stops designated by a channel number (*n0*) from 0 to 7. The tab stops in each channel are set by <ESC> “b”

Vertical tab

ASCII	Decimal	Hexadecimal
<VT>	11	0B

Feeds the paper to the next vertical tab stop and moves the print position to the left margin. Performs a line feed if no vertical tabs are set, as at power-up. Feeds to the top of the next page if vertical tabs are set but the current line is at or below the last vertical tab stop.

HORIZONTAL POSITION COMMANDS

Set left margin

ASCII	Decimal	Hexadecimal
<ESC> "I" <i>n</i>	27 108 <i>n</i>	1B 6C <i>n</i>

Sets the left margin at column *n* (where *n* is between 0 and 255) in the current character pitch (pica pitch if proportional spacing is selected). The left margin does not move if the character pitch is changed later. The left margin must be at least two columns to the left of the right margin and within the limits below:

Pica	$0 \leq n \leq 76$
Elite	$0 \leq n \leq 91$
Semi-condensed	$0 \leq n \leq 114$
Condensed pica	$0 \leq n \leq 130$
Condensed elite	$0 \leq n \leq 152$
Expanded pica	$0 \leq n \leq 38$
Expanded elite	$0 \leq n \leq 45$
Expanded semi-condensed	$0 \leq n \leq 57$
Expanded condensed pica	$0 \leq n \leq 64$
Expanded condensed elite	$0 \leq n \leq 76$

Set right margin

ASCII	Decimal	Hexadecimal
<ESC> "Q" <i>n</i>	27 81 <i>n</i>	1B 51 <i>n</i>

Sets the right margin at column *n* in the current character pitch (pica pitch if proportional spacing is currently selected). Column *n* becomes the last character position in the line. The right margin does not move if the character pitch is changed later. The right margin must be within the limits below:

Pica	$4 \leq n \leq 80$
Elite	$5 \leq n \leq 96$
Semi-condensed	$6 \leq n \leq 120$
Condensed pica	$7 \leq n \leq 137$
Condensed elite	$8 \leq n \leq 160$
Expanded pica	$2 \leq n \leq 40$
Expanded elite	$3 \leq n \leq 48$
Expanded semi-condensed	$3 \leq n \leq 60$
Expanded condensed pica	$4 \leq n \leq 68$
Expanded condensed elite	$4 \leq n \leq 80$

Carriage return

ASCII	Decimal	Hexadecimal
<CR>	13	0D

Prints the current line and returns the next print position to the left margin. If EDS switch A-3 is set to OFF, also performs a line feed.

Backspace

ASCII	Decimal	Hexadecimal
<BS>	8	08

Moves the print position one column to the left. Ignored if the print position is at the left margin. This command can be used to overstrike or combine characters.

Set horizontal tab stops

ASCII	Decimal	Hexadecimal
<ESC> "D" <i>n1 n2 ...</i> <0>	27 68 <i>n1 n2 ...</i> 0	1B 44 <i>n1 n2 ...</i> 00

Cancels all current horizontal tab stops and sets new tab stops at columns *n1*, *n2*, etc. in the current character pitch (pica pitch if proportional spacing is currently selected), where *n1*, *n2*, etc. are numbers between 1 and 255. The maximum number of horizontal tab stops allowed is 32. The tab stops must be specified in ascending order; any violation of ascending order terminates the tab stop list. Standard termination is by the <0> control code. To clear all tab stops, specify <ESC> "D" <0>.

Horizontal tab

ASCII	Decimal	Hexadecimal
<HT>	9	09

Moves the print position to the next horizontal tab stop. Ignored if there is no next horizontal tab stop in the current line. Note that when underlining is selected, spaces skipped by horizontal tabulation are not underlined.

Relative horizontal tab

ASCII	Decimal	Hexadecimal
<ESC> “\” <i>n1 n2</i>	27 92 <i>n1 n2</i>	1B 5C <i>n1 n2</i>

Moves the print position right or left a specified distance. Ignored if the resulting position is beyond the right or left margin. The formulas for the distance and direction are as follows:

If *n2* is between 0 and 63, the print head moves right by $(n1 + n2 \times 256)$ dots.

If you want to move the print head to the left, *n1* and *n2* are obtained by subtracting the value from 65536, and dividing the result into high and low bytes.

The unit of movement is fixed at 1/120 inch in draft mode and 1/180 inch in LQ mode.

Absolute horizontal tab in inches

ASCII	Decimal	Hexadecimal
<ESC> “\$” <i>n1 n2</i>	27 36 <i>n1 n2</i>	1B 24 <i>n1 n2</i>

Sets the next print position to $(n1 + n2 \times 256)/60$ inches from the left margin on the current line. Ignored if this position is beyond the right margin.

GRAPHICS COMMANDS

Print normal-density 8-bit graphics

ASCII	Decimal	Hexadecimal
<ESC> “K” $n1\ n2$ $m1\ m2\ \dots$	27 75 $n1\ n2$ $m1\ m2\ \dots$	1B 4B $n1\ n2$ $m1\ m2\ \dots$

Prints bit-image graphics at 60 dots per inch horizontally. The graphic image is 8 dots high and $n1 + n2 \times 256$ dots wide. Maximum width is 8 inches (480 dots). $m1, m2, \dots$ are the dot data, each a 1-byte value from 0 to 255 representing 8 vertical dots, with the most significant bit at the top and the least significant bit at the bottom. The number of data bytes must be $n1 + n2 \times 256$. Dots beyond the right margin are ignored. At the end of bit-image printing the printer returns automatically to character mode.

Print double-density 8-bit graphics

ASCII	Decimal	Hexadecimal
<ESC> “L” $n1\ n2$ $m1\ m2\ \dots$	27 76 $n1\ n2$ $m1\ m2\ \dots$	1B 4C $n1\ n2$ $m1\ m2\ \dots$

Prints bit-image graphics at 120 dots per inch horizontally (maximum 960 dots wide). See <ESC> “K” for other information.

Print double-density, double-speed 8-bit graphics

ASCII	Decimal	Hexadecimal
<ESC> “Y” $n1\ n2$ $m1\ m2\ \dots$	27 89 $n1\ n2$ $m1\ m2\ \dots$	1B 59 $n1\ n2$ $m1\ m2\ \dots$

Prints bit-image graphics at 120 dots per inch horizontally (maximum 960 dots wide), skipping every second dot in the horizontal direction. See <ESC> “K” for other information.

Print quadruple-density 8-bit graphics

ASCII	Decimal	Hexadecimal
<ESC> "Z" $n1\ n2$ $m1\ m2\ \dots$	27 90 $n1\ n2$ $m1\ m2\ \dots$	1B 5A $n1\ n2$ $m1\ m2\ \dots$

Prints bit-image graphics at 240 dots per inch horizontally (maximum 1920 dots wide), skipping every second dot in the horizontal direction. See <ESC> "K" for other information.

Print hex-density 24-bit graphics

ASCII	Decimal	Hexadecimal
<FS> "Z" $n1\ n2$ $m1\ m2\ m3\ \dots$	28 90 $n1\ n2$ $m1\ m2\ m3\ \dots$	1C 5A $n1\ n2$ $m1\ m2\ m3\ \dots$

Prints 24-bit dot graphics at 360 dots per inch horizontally. The graphics image is 24 dots high and $n1 + n2 \times 256$ dots wide. Maximum width is 8 inches (2880 dots). In the data $m1, m2, m3 \dots$ each three bytes represent 24 vertical dots. In the leftmost position, the most significant bit of $m1$ is the top dot; the least significant bit of $m1$ is the eighth dot from the top; the most significant bit of $m2$ is the ninth dot; the least significant bit of $m2$ is the sixteenth dot from the top; the most significant bit of $m3$ is the seventeenth dot from the top; the least significant bit of $m3$ is the bottom dot. The rest of the data is similar. The number of data bytes must be $3 \times (n1 + n2 \times 256)$. Dots beyond the right margin are ignored. At the end of dot graphics printing, the printer returns automatically to character mode.

Select graphics mode

ASCII	Decimal	Hexadecimal
<ESC> “*” <i>n0 n1</i> <i>n2 m1 m2 ...</i>	27 42 <i>n0 n1</i> <i>n2 m1 m2 ...</i>	1B 2A <i>n0 n1</i> <i>n2 m1 m2 ...</i>

Selects one of eleven graphics modes depending on the value of *n0* and prints bit-image graphics in this mode. See <ESC> “K” (for 8-bit graphics) or <FS> “Z” (for 24-bit graphics) for information on *n1*, *n2*, *m1*, *m2*, ...

<i>n0</i>	Graphics mode	
0	8-bit Normal-density	(60 dots per inch)
1	8-bit Double-density	(120 dots per inch)
2	8-bit Double-density, double-speed	(120 dots per inch)
3	8-bit Quadruple-density	(240 dots per inch)
4	8-bit CRT graphics, mode I	(80 dots per inch)
6	8-bit CRT graphics, mode II	(90 dots per inch)
32	24-bit Normal-density	(60 dots per inch)
33	24-bit Double-density	(120 dots per inch)
38	24-bit CRT graphics	(90 dots per inch)
39	24-bit Triple-density	(180 dots per inch)
40	24-bit Hex-density	(360 dots per inch)

Convert graphics density

ASCII	Decimal	Hexadecimal
<ESC> “?” <i>n m</i>	27 63 <i>n m</i>	1B 3F <i>n m</i>

Converts graphics defined by subsequent <ESC> “K”, <ESC> “L”, <ESC> “Y” or <ESC> “Z” commands to a density mode defined by <ESC> “?”. *n* is “K”, “L”, “Y” or “Z”, indicating the mode to be converted. *m* is a code from <0> to <4> or <6> indicating one of the modes of <ESC> “?”.

DOWNLOAD CHARACTER COMMANDS

Define download characters

ASCII	Decimal	Hexadecimal
<ESC> "&" <0> <i>n1</i>	27 38 0 <i>n1</i>	1B 26 00 <i>n1</i>
<i>n2 m0 m1 m2</i>	<i>n2 m0 m1 m2</i>	<i>n2 m0 m1 m2</i>
<i>d1 d2 ... dx</i>	<i>d1 d2 ... dx</i>	<i>d1 d2 ... dx</i>

Defines one or more new characters (up to 127 characters) and stores them in RAM for later use. EDS switches A-1 and A-2 must be set OFF; otherwise RAM is used as an input buffer, not downloading characters and this command is ignored.

n1 is the character code of the first character defined and *n2* is the character code of the last character defined. *n1* must be equal to or less than *n2*.

The data for each character start with three bytes specifying proportional spacing attributes: the first byte, *m0*, specifies the left of the character; the second byte, *m1*, specifies the character width; the third byte, *m2*, specifies the right of the character.

These values must not exceed the following maximum limits:

Character mode	<i>m1</i>	<i>m0 + m1 + m2</i>
Draft	9	12
LQ pica	31	36
LQ elite	27	30
LQ semi-condensed	19	24
LQ proportional	37	42
Draft super/subscript	7	12
LQ super/subscript	19	36
LQ prop. super/subscript	37	42

Next comes the dot data. Normal character height is 24 dots, so there must be $3 \times m1$ bytes of dot data. If the printer is in super/subscript mode, however, the character height is 16 dots, so there must be $2 \times m1$ bytes of dot data.

Each data byte indicates eight vertical dots, with the most significant bit being the top dot, and the least significant bit being the bottom dot.

Copy character set from ROM into RAM

ASCII	Decimal	Hexadecimal
<ESC> “:” <0> n <0>	27 58 0 n 0	1B 3A 00 n 00

Copies the selected character set with *n*, as shown below, to the corresponding download character RAM area, overwriting any download data already present. Ignored when EDS switches A-1 and A-2 are not set OFF.

<i>n</i>	Font
0	Roman
1	Sanserif
2	Courier
3	Prestige
4	Script

Select download character set

ASCII	Decimal	Hexadecimal
<ESC> “%” <1>	27 37 1	1B 25 01

Selects the download character set. Ignored when EDS switches A-1 and A-2 are not set OFF.

Shift download character area

ASCII	Decimal	Hexadecimal
<FS> “T” <2>	28 73 2	1C 49 02

Shifts the download character area defined between 0 to 127 to the area between 128 to 255.

Select ROM character set

ASCII	Decimal	Hexadecimal
<ESC> “%” <0>	27 58 0	1B 25 00

Stops using the download character set and returns to the built-in ROM character set. Ignored when EDS switches A-1 and A-2 are not set OFF.

OTHER PRINTER COMMANDS

Set MSB to 1

ASCII	Decimal	Hexadecimal
<ESC> “>”	27 62	1B 3E

Sets the most significant bit of each subsequent byte received to 1, allowing users with a 7-bit interface to access characters with ASCII codes greater than 127.

Set MSB to 0

ASCII	Decimal	Hexadecimal
<ESC> “=”	27 61	1B 3D

Sets the most significant bit of each subsequent byte received to 0.

Accept MSB as is

ASCII	Decimal	Hexadecimal
<ESC> “#”	27 35	1B 23

Cancels the preceding commands and accepts the most significant bit as it is sent to the printer.

Delete last character sent

ASCII	Decimal	Hexadecimal
	127	7F

Deletes the last character received. Ignored if the last character received has already been printed, or if the last character received was all or part of a command.

Cancel last line

ASCII	Decimal	Hexadecimal
<CAN>	24	18

Deletes the last line currently present in the print buffer.

Set printer off-line

ASCII	Decimal	Hexadecimal
<DC3>	19	13

Sets the printer off-line. The printer disregards all subsequent characters and commands except <DC1>, which returns it to the on-line. The printer's ON LINE indicator does not go off.

Set printer on-line

ASCII	Decimal	Hexadecimal
<DC1>	17	11

Returns the printer to on-line state, allowing it to receive and process all subsequent characters and commands. This command is ignored if the printer was set off-line by pressing the ON LINE button on the control panel.

Bell

ASCII	Decimal	Hexadecimal
<BEL>	7	07

Sounds a brief beep tone from the printer.

Bi-directional printing

ASCII	Decimal	Hexadecimal
<ESC> "U" <0>	27 85 0	1B 55 00

Causes subsequent printing to be done in the normal bi-directional mode, which is faster than uni-directional printing.

Uni-directional printing

ASCII	Decimal	Hexadecimal
<ESC> "U" <1>	27 85 1	1B 55 01

Causes subsequent printing to be done uni-directionally, ensuring maximum vertical alignment precision.

One-line uni-directional printing

ASCII	Decimal	Hexadecimal
<ESC> “<”	27 60	1B 3C

Immediately returns the print head to the left margin, then prints the remainder of the line from left to right. Normal printing resumes on the next line.

Manual feed

ASCII	Decimal	Hexadecimal
<ESC> <0>	27 25 0	1B 19 00

Selects manual sheet feeding even when the optional automatic sheet feeder is mounted. Ignored if EDS switch A-4 is set on.

Auto feed

ASCII	Decimal	Hexadecimal
<ESC> <0> <4>	27 25 4	1B 19 04

Selects the automatic sheet feeder. Ignored if EDS switch A-4 is ON.

Eject paper from ASF

ASCII	Decimal	Hexadecimal
<ESC> “R”	27 25 82	1B 19 52

Ejects the current page. Ignored if EDS switch A-4 is set on.

Set print start position on ASF

ASCII	Decimal	Hexadecimal
<ESC> “T” <i>n</i>	27 25 84 <i>n</i>	1B 19 54 <i>n</i>

Skips *n*/6 inches at the top of the page, where *n* is equal to or greater than 1. Ignored if EDS switch A-4 is ON.

Reset printer

ASCII	Decimal	Hexadecimal
<ESC> “@”	27 64	1B 40
<FS> “@”	28 64	1C 40

Reinitializes the printer. Clears the print buffer and returns settings to their power-up values. Does not clear the input buffer or change ASF selections.

Chapter 9

DOWNLOAD CHARACTERS

With this printer you can create new characters and symbols, download their dot data, and have them printed in place of selected characters in the regular character set. Characters that can be generated in this way range from simple but useful symbols like the check mark through to complex Chinese or Japanese characters.

Regular characters are permanently stored in the printer's ROM, but characters you design are downloaded and stored in RAM for use.

Before you start to define your own characters, you must set the EDS switches A-1 and A-2 to the OFF position. Otherwise, the RAM is used to store the input buffer, and the download commands are ignored.

Designing and printing your own characters has two requirements: first, designing the shape of the character, calculating the data necessary to make the shape, and sending that data to the printer, and secondly, sending the command to print the downloaded characters instead of the regular characters. There are a number of design constraints for download characters:

- The matrix or grid on which you design the characters depends upon the print mode as shown below:

Character mode	Horizontal	Vertical
Draft characters	9	24
LQ pica characters	31	24
LQ elite characters	27	24
LQ semi-condensed	19	16
LQ proportional	37	24
Draft super/subscript	7	16
LQ super/subscript	19	16
LQ prop. super/subscript	37	16

- The minimum width of a character is five dots.
- Dots cannot overlap.
- You may define any position in the ASCII table up to 127 characters.

Photocopy the grid in Figure 9-1 to help design your new characters. We will use a tiny representation of a telephone symbol for our example.

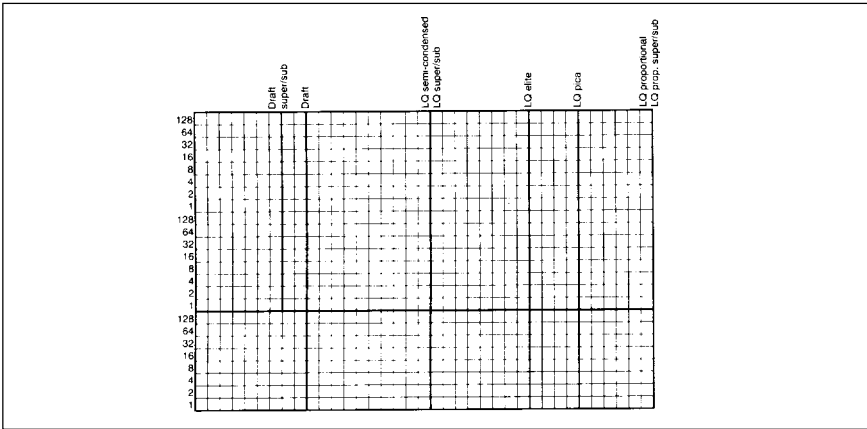

Figure 9-1. Use this grid (or one similar to it) to define your own characters.

ASSIGNING THE CHARACTER DATA

Now, we calculate the vertical numerical values of the columns of dots, and enter them underneath the grid. Each vertical column (which has a maximum of 24 dots) is first divided into three groups (or two groups for super/subscripts) of eight dots. Each group of eight dots is represented by one byte, which consists of eight bits.

This is where the numbers down the left side of the grid come in. Notice that there is a number for each row of dots and that each number is twice the number below it. By making these numbers powers of two we can take any combination of dots in a vertical column and assign them a unique value.

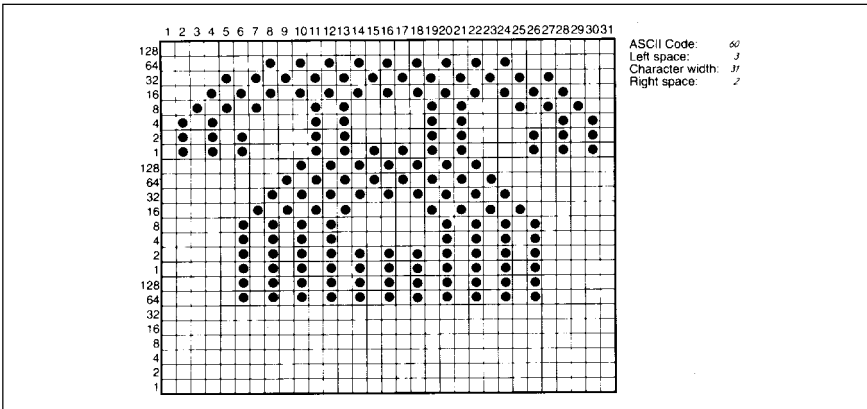

Figure 9-2. Telephone symbol with normal LQ pica.

ASSIGNING A VALUE OF CHARACTER SPACE

Besides being able to specify the actual width of the character, this printer allows you to specify the position in the standard grid where the character will print. You must specify the dot column in which the printed character starts and the dot column in which the character ends. Why, you may ask, would you want to define a character this way instead of merely defining the overall width of the character? Because this printer's proportional character definitions can also be used to print normal width characters, and by centering even the narrow characters in the complete grid they will look good even if you are not printing them proportionally.

The three bytes are used to specify the width of the character and the space to be allowed on either side of it. The left space (in dot columns) is specified by $m0$ and the right space is specified by $m2$. The second byte ($m1$) specifies the width of the character in dots. By varying the width of the character itself and the spaces around it, you can actually create proportional width characters.

When defining characters, the number of printed columns ($m1$), and the sum of side spaces and the character width ($m0 + m1 + m2$) cannot exceed the value shown below.

Character mode	$m1$	$m0 + m1 + m2$
Draft characters	9	12
LQ pica characters	31	36
LQ elite characters	27	30
LQ semi-condensed	19	24
LQ proportional	37	42
Draft super/subscript	7	12
LQ super/subscript	19	36
LQ prop. super/subscript	37	42

SAMPLE PROGRAM

To demonstrate how to use the download characters, let's use the "telephone" character and the other user-defined characters to print a small graph. This program will do just that:

```
1000 WIDTH "LPT1:",255
1010 LPRINT CHR$(27);"x1";
1020 LPRINT CHR$(27);"&";CHR$(0);
1030 LPRINT CHR$(60);CHR$(61);
1040 FOR N=60 TO 61
```

```

1050 READ LS :LPRINT CHR$(LS);
1060 READ CW :LPRINT CHR$(CW);
1070 READ RS :LPRINT CHR$(RS);
1080 FOR M=1 TO CW*3
1090 READ MM
1100 LPRINT CHR$(MM);
1110 NEXT M
1120 NEXT N
1130 LPRINT CHR$(27);"D";CHR$(11);CHR$(0)
1140 LPRINT CHR$(27);"k";CHR$(4);
1150 LPRINT CHR$(27);"w";CHR$(1);CHR$(27);"W";CHR$(1);
1160 LPRINT "    DIFFUSION RANGES OF" :LPRINT
1170 LPRINT "    CARS & TELEPHONES"
1180 LPRINT CHR$(27);"w";CHR$(0);CHR$(27);"W";CHR$(0)
1190 LPRINT CHR$(27);"k";CHR$(0);
1200 LPRINT CHR$(27);"%";CHR$(1);
1210 LPRINT "USA";CHR$(9);
1220 FOR I=0 TO 681 STEP 25 :LPRINT CHR$(60); :NEXT I
1230 LPRINT
1240 LPRINT CHR$(9);
1250 FOR I=0 TO 781 STEP 25 :LPRINT CHR$(61); :NEXT I
1260 LPRINT
1270 LPRINT "GERMANY";CHR$(9);
1280 FOR I=0 TO 412 STEP 25 :LPRINT CHR$(60); :NEXT I
1290 LPRINT
1300 LPRINT CHR$(9);
1310 FOR I=0 TO 488 STEP 25 :LPRINT CHR$(61); :NEXT I
1320 LPRINT
1330 LPRINT "JAPAN";CHR$(9);
1340 FOR I=0 TO 347 STEP 25 :LPRINT CHR$(60); :NEXT I
1350 LPRINT
1360 LPRINT CHR$(9);
1370 FOR I=0 TO 493 STEP 25 :LPRINT CHR$(61); :NEXT I
1380 LPRINT
1390 LPRINT CHR$(9);"+-";
1400 SCALE$="+-+"
1410 FOR I=2 TO 8 :LPRINT SCALE$; :NEXT I
1420 LPRINT "+-+"
1430 LPRINT CHR$(9);"0 ";
1440 FOR I=1 TO 8
1450 LPRINT " ";I;
1460 NEXT I
1470 LPRINT CHR$(27);"%";CHR$(0)
1480 LPRINT CHR$(27);"M";
1490 LPRINT CHR$(27);"S";CHR$(0);
1500 LPRINT CHR$(9);"(100 UNITS/1000 PERSONS)"
1510 LPRINT CHR$(27);"T";
1520 LPRINT CHR$(27);"@"
1530 END
2000 ' DATA
2010 ' Telephone Symbol
2020 DATA 3, 31, 2
2030 DATA 0, 0, 0, 7, 0, 0, 8, 0, 0, 23, 0, 0, 40, 0, 0
2040 DATA 19, 15,192, 40, 16, 0, 80, 47,192, 32, 80, 0, 80,175,192

```

MEMO

Chapter 10

MS-DOS AND YOUR PRINTER

When using your printer with an IBM PS/2, PC-AT or compatible, you will probably be using PC-DOS or MS-DOS as an operating system. A number of software tricks may be useful here. This chapter is not, however, a substitute for the operating system manuals supplied with your computer.

To learn how to print files, etc. it is best to read the relevant parts of these manuals.

PROGRAMMING THE PRINTER WITH DOS COMMANDS

If your system includes the file PRINT.COM you can use the main DOS printing command. Simply type the word PRINT followed by the name of the file you want to print. To print a file named README.DOC, for example, type:

```
A>PRINT README.DOC
```

The computer may respond with the following message, asking which printer to use:

```
Name of list device [PRN]:
```

If your computer is connected to only one printer, press RETURN to select the default choice (PRN).

Printing will begin and the A> prompt will reappear. You can execute other commands or programs while the file is being printed.

A single PRINT command can print two or more files. List the file names consecutively on the same line, or use wild-card characters (* and ?). Each file will be printed starting on a new page. The PRINT command also has control options. For example, you can terminate a printing job in progress with the /T option. (The printer may not stop printing immediately as there may be considerable data stored ahead in its buffer.) For the /T option, type:

```
A>PRINT/T
```

See your DOS manual for further information about the PRINT command. If your system does not include PRINT.COM, you can print files by using the PRN device name in COPY or TYPE commands such as the following:

```
A>COPY README.DOC PRN
A>TYPE README.DOC >PRN
```

COPY and TYPE do not permit you to execute other commands while the file is printing.

If you want a particular font, or print pitch, you can make these settings from the control panel before you start printing. See Chapter 4.

If you print from the DOS command level very often, it will be advantageous to create a printer setup file. Then instead of setting font style etc. manually each time, you can complete the setup with a single command from your computer. For example, you can create a file containing printer commands to select letter quality, and select elite pitch. You can find the commands in Chapter 8. We suggest the following:

- Letter quality <ESC> “x” “1”
- Elite pitch <ESC> “!” <1>

<ESC> “!” <1> is a powerful command that, in addition to selecting elite pitch, cancels unwanted features such as underlining which might be left from previous commands. The angle brackets around the <1> indicate character code 1, which is a control code, not the printable digit “1”.

You may want to place additional commands in this file, such as left and right margins, line spacing and bottom margin commands. Or you may want to create a variety of setup files with a different set of commands in each.

To avoid excess line feeds, you should place the commands on one line in the setup file. You may or may not be able to generate a setup file with word-processing software; it depends on whether your software lets you enter control codes. If your system includes the file EDLIN.COM, however, you can easily create a setup file with the DOS line editor.

An appropriate name for this setup file would be LQELITE.DAT. To use the DOS line editor, type the command EDLIN LQELITE.DAT, then type the underlined parts of the following display. Press RETURN at the end of each line. Do not type the symbol “^”. This symbol means to hold the CTRL key down while pressing the next key: for example, ^V means to type CTRL-V. ^C means to type CTRL-C, which indicates the end of the input.

```
A>EDLIN LQELITE.DAT
New file
*I
  1: *^V[x1^V]!^VA
  2: *^C
*E
```

^V indicates that the following character is a control code. ^V[enters the <ESC> code. <ESC> has character code 27, and “[” is the 27th character from A in the ASCII sequence. Similarly, ^VA enters the control code <1>. See your DOS manual if you need further information about EDLIN.

You can now set up the printer by sending it the file LQELITE.DAT. To avoid unnecessary logging of commands, switch hard-copy output off (by pressing CTRL-PRTS if hard copy is on). To print the file README.DOC in LQ elite type, give the following two commands:

```
A>COPY LQELITE.DAT PRN
A>PRINT README.DOC
```

For greater convenience you can make a batch file that will set up the printer and print any specified file with a single command. To create such a batch file with the name LQPRINT.BAT, type in the first four lines shown next. ^Z means to press the CTRL and Z keys simultaneously. To use this file to print README.DOC, type the fifth line.

```
A>COPY CON LQPRINT.BAT
COPY LQELITE.DAT PRN
PRINT %1
^Z
A>LQPRINT README.DOC
```

The first line above is a copy command from the CONsole screen to a file named LQPRINT.BAT. The next two lines are the contents of this file. The %1 is a dummy parameter: whatever file name you type after LQPRINT will be substituted for %1 and printed.

PROGRAMMING WITH BASIC

As an example of programming the printer on Microsoft BASIC, we have listed the program for the IBM-PC. This program runs in the downloadable condition.

```
1000 ' Set control codes
1010 E$=CHR$(27) 'Escape code
1020 D$=E$+"x0" 'Draft quality
1030 L$=E$+"x1"+E$+"k" 'Letter quality
1040 R$=L$+CHR$(0) 'Roman character
1050 H$=CHR$(9) 'Horizontal tab
1060 P$=E$+"P" 'Pica pitch
1070 ' Start printing
1080 WIDTH "LPT1:",255
1090 LPRINT E$;"D";CHR$(3);CHR$(24);CHR$(0) 'Set HT
1100 LPRINT R$;"Resident fonts are:"
1110 LPRINT H$;D$;"Draft characters,";
1120 LPRINT H$;L$;CHR$(0);"Roman characters,"
1130 LPRINT H$;L$;CHR$(1);"Sanserif characters,";
1140 LPRINT H$;L$;CHR$(2);"Courier characters,"
1150 LPRINT H$;L$;CHR$(3);"Prestige characters,";
1160 LPRINT H$;L$;CHR$(4);"Script characters."
1170 LPRINT
1180 LPRINT R$;"Print pitches are:"
1190 LPRINT H$;P$;"Pica pitch (10 CPI),";
1200 LPRINT H$;E$;"M";"Elite pitch (12 CPI),";
1210 LPRINT H$;E$;"g";"Semi-condensed pitch (15 CPI),";
1220 LPRINT H$;P$;
1230 LPRINT CHR$(15); 'Select condensed print
1240 LPRINT "Condensed pica pitch (17 CPI).";
1250 LPRINT H$;E$;"M";"Condensed elite pitch (20 CPI).";
1260 LPRINT CHR$(18) 'Cancel condensed print
1270 LPRINT H$;E$;"p1"; 'Select proportional spacing
1280 LPRINT P$;"Normal proportional,";
1290 LPRINT H$;CHR$(15);"Condensed proportional,";
1300 LPRINT CHR$(18);
1310 LPRINT E$;"p0" 'Cancel proportional spacing
1320 LPRINT
1330 LPRINT H$;E$;"w1";"Double-height,";E$;"w0"
1340 LPRINT H$;E$;"W1";"Double width, ";E$;"W0"
1350 LPRINT H$;CHR$(28);"E";CHR$(2);"Triple width,";
1360 LPRINT CHR$(28);"E";CHR$(0)
1370 LPRINT
1380 LPRINT R$;"Various line and character spacings:"
1390 FOR I=1 TO 7
1400 LPRINT E$;"A";CHR$(I); 'Line spacing set
1410 LPRINT E$;" ";CHR$(I); 'Increase character space
1420 LPRINT H$;"THE SPACINGS ARE CHANGED"
1430 NEXT I
1440 FOR I=7 TO 1 STEP -1
1450 LPRINT E$;"A";CHR$(I); 'Line spacing set
1460 LPRINT E$;" ";CHR$(I); 'Increase character space
```

```

1470 LPRINT H$:"THE SPACINGS ARE CHANGED"
1480 NEXT I
1490 LPRINT E$;"3";CHR$(30);           'Set 1/6" line spacing
1500 LPRINT E$;" ";CHR$(0);           'Normal character space
1510 LPRINT :LPRINT
1520 LPRINT RM$:"Other features:"
1530 LPRINT H$;E$;"q";CHR$(1);"OUTLINED";E$;"q";CHR$(0);", " ;
1540 LPRINT E$;"q";CHR$(2);"SHADOWED";E$;"q";CHR$(0);", " ;
1550 LPRINT E$;"q";CHR$(3);"OUTLINED WITH SHADOWED";
1560 LPRINT E$;"q";CHR$(0);", "
1570 LPRINT H$;E$;"E";"Emphasized";E$;"F";", " ;
1580 LPRINT E$;"G";"Double-strike";E$;"H";", " ;
1590 LPRINT E$;"4";"Italics";E$;"5";", "
1600 LPRINT H$;E$;"-1";"Underlining";E$;"-0";", " ;
1610 LPRINT E$;"(-";CHR$(3);CHR$(0);CHR$(1);CHR$(2);CHR$(2);
1620 LPRINT "Strike-through";
1630 LPRINT E$;"(-";CHR$(3);CHR$(0);CHR$(1);CHR$(2);CHR$(0);", " ;
1640 LPRINT E$;"(-";CHR$(3);CHR$(0);CHR$(1);CHR$(3);CHR$(1);
1650 LPRINT "Overlining";
1660 LPRINT E$;"(-";CHR$(3);CHR$(0);CHR$(1);CHR$(3);CHR$(0);", "
1670 LPRINT H$;E$;"S0";"SUPERSCRIPT";E$;"T";" and " ;
1680 LPRINT E$;"S1";"SUBSCRIPT";E$;"T";", "
1690 LPRINT H$;RM$:"Download characters: " ;
1700 SSS=E$+"S0"                       'Superscript
1710 GOSUB 2520
1720 LPRINT E$;"%1";                     'Select download character
1730 FOR I=1 TO 5
1740 LPRINT CHR$(60);                     'Print download character
1750 NEXT I
1760 LPRINT E$;"%0";                     'Select normal character
1770 LPRINT E$;"T";                       'Cancel superscript
1780 GOSUB 2650
1790 LPRINT E$;"%1";                     'Select download character
1800 FOR I=1 TO 5
1810 LPRINT CHR$(60);                     'Print download character
1820 NEXT I
1830 LPRINT E$;"%0";                     'Select normal character
1840 SSS=E$+"S1"                         'Subscript
1850 GOSUB 2520
1860 LPRINT E$;"%1";                     'Select download character
1870 FOR I=1 TO 5
1880 LPRINT CHR$(60);                     'Print download character
1890 NEXT I
1900 LPRINT E$;"%0";                     'Select normal character
1910 LPRINT E$;"T"                       'Cancel superscript
1920 LPRINT H$;RM$:"Dot graphics:"
1930 RESTORE 3170
1940 LPRINT E$;"A";CHR$(8);               'Set 8/60" line spacing
1950 FOR I=1 TO 3
1960 LPRINT E$;"$";CHR$(60);CHR$(0);     'Absolute tab
1970 LPRINT E$;"*";CHR$(33);CHR$(240);CHR$(0);
1980 FOR J=1 TO 240*3
1990 READ DAT
2000 LPRINT CHR$(DAT);

```

3200 DATA	0.	0.	0.	0.	0.	0.	0.	0.	0.	0.	0.	0.	0.	0.	0.
3210 DATA	0.	0.	0.	0.	0.	0.	0.	0.	0.	0.	0.	0.	0.	0.	0.
3220 DATA	0.	0.	0.	0.	0.	0.	0.	0.	0.	0.	0.	0.	0.	0.	0.
3230 DATA	0.	0.	0.	0.	0.	0.	0.	0.	0.	0.127,255.	0.255,255				
3240 DATA	1,255,255.	3.	0.	0.	7.	0.	0.	7.	0.	0.	15.	0.	0.		
3250 DATA	31.	0.	0.	31.	0.	0.	31.	0.	0.	31.	0.	0.	31.	0.	0.
3260 DATA	31.	0.	0.	31.	0.	0.	31.	0.	0.	31.	0.	0.	31.	0.	0.
3270 DATA	31.	0.	0.	31.	0.	0.	31.	0.	0.	31.	0.	0.	31.	0.	0.
3280 DATA	31.	0.	0.	31,128.	0.	31,224.	0.	31,248.	0.	31,255.	0.				
3290 DATA	31,255,224.	15,255,248.	7,255,255.	1,255,255.	0,127,255										
3300 DATA	0.	7,255.	0.	0,255.	0.	0.	63.	0.	0.	63.	0.	0.	0,248		
3310 DATA	0.	3,192.	0.	63.	0.	0,248.	0.	1,128.	0.	3.	0.	0.			
3320 DATA	7.	0.	0.	15.	0.	0.	15.	0.	0.	31.	0.	0.	31.	0.	0.
3330 DATA	31.	0.	0.	31.	0.	0.	31.	0.	0.	31.	0.	0.	31.	0.	0.
3340 DATA	31.	0.	0.	31.	0.	0.	31.	0.	0.	31.	0.	0.	31.	0.	0.
3350 DATA	31.	0.	0.	31.	0.	0.	31.	0.	0.	31.	0.	0.	31.	0.	0.
3360 DATA	31,255,255.	31,255,255.	31,255,255.	31,255,255.	31,255,255.	31,255,255.	31,255,255.	31,255,255.	31,255,255.	31,255,255.	31,255,255.	31,255,255.	31,255,255.	31,255,255.	31,255,255.
3370 DATA	31,255,255.	15,255,255.	15,255,255.	0.	0.	0.	0.	0.	0.	0.	0.	0.	0.	0.	0.
3380 DATA	0.	0.	0.	0.	0.	0.	0.	0.	0.	0.	0.	0.	0.	0.	0.
3390 DATA	0.	0.	0.	0.	0.	0.	0.	0.	0.	0.	0.	0.	0.	0.	0.
3400 DATA	0.	0.	0.	0.	0.	60.	0.	3,255.	0.	11,195.	0.	28.	0.		
3410 DATA	0.	12.	0.	0.	96.	0.	0,192.	0.	0,192.	0.	1,128.	0.			
3420 DATA	3.	0.	0.	3.	0.	0.	7.	0.	0.	7.	0.	0.	15.	0.	0.
3430 DATA	15.	0.	0.	31.	0.	0.	31.	0.	0.	31.	0.	0.	31.	0.	15.
3440 DATA	31.	0.	31.	31.	0.	31.	31.	0.	31.	31.	0.	31.	31.	0.	31.
3450 DATA	31.	0.	31.	31.	0.	31.	31.	0.	31.	31.	0.	31.	31.	0.	31.
3460 DATA	31.	0.	31.	31.	0.	31.	31.	0.	31.	31.	0.	31.	31.	0.	31.
3470 DATA	31.	0.	31.	31.	0.	31.	31.	0.	31.	31.	0.	31.	31.	0.	63.
3480 DATA	31,255,255.	31,255,255.	31,255,247.	31,255,231.	31,255,199										
3490 DATA	15,255,135.	7,255.	7.	0.	0.	3.	0.	0.	1.	0.	0.	0.			
3500 DATA	0.	0.	0.	0.	0.	0.	0.	0.	0.	0.	0.	0.	0.	0.	0.
3510 DATA	0.	0.	0.	0.	0.	0.	0.	0.	0.	0.	0.	0.	0,254.	0.	0.
3520 DATA	1,255,240.	3,135,255.	7.	0.	63.	15.	0.	0.	15.	0.	0.				
3530 DATA	31.	0.	0.	31.	0.	0.	31.	0.	0.	31.	0.	0.	31.	0.	0.
3540 DATA	31.	0.	0.	31.	0.	0.	31.	0.	0.	31,128.	0.	31,128.	0.		
3550 DATA	31,192.	0.	31,255.	0.	31,255,255.	31,255,255.	31,255,255.	31,255,255.	31,255,255.	31,255,255.	31,255,255.	31,255,255.	31,255,255.	31,255,255.	31,255,255.
3560 DATA	31,255,255.	15,255,255.	7,255,255.	0,255,255.	0,255,255.	0,255,255.	0,255,255.	0,255,255.	0,255,255.	0,255,255.	0,255,255.	0,255,255.	0,255,255.	0,255,255.	0,255,255.
3570 DATA	1,240.	0.	3,128.	0.	7.	0.	0.	15.	0.	0.	31.	0.	0.	31.	0.
3580 DATA	31.	0.	0.	31.	0.	0.	31.	0.	0.	31.	0.	0.	31.	0.	0.
3590 DATA	31.	0.	0.	31.	0.	0.	31.	0.	0.	31,128.	0.	31,128.	0.		
3600 DATA	31,192.	0.	31,240.	0.	31,255.	0.	31,255,240.	31,255,255.	31,255,255.	31,255,255.	31,255,255.	31,255,255.	31,255,255.	31,255,255.	31,255,255.
3610 DATA	31,255,255.	7,255,255.	0,255,255.	0,255,255.	0,255,255.	0,255,255.	0,255,255.	0,255,255.	0,255,255.	0,255,255.	0,255,255.	0,255,255.	0,255,255.	0,255,255.	0,255,255.
3620 DATA	3,192.	0.	7,128.	0.	15.	0.	0.	31.	0.	0.	31.	0.	0.	31.	0.
3630 DATA	31.	0.	0.	31.	0.	0.	31.	0.	0.	31.	0.	0.	31.	0.	0.
3640 DATA	31.	0.	0.	31.	0.	0.	31.	0.	0.	31.	0.	15.	31,135,255		
3650 DATA	31,255,255.	31,255,255.	31,255,255.	31,255,255.	31,255,255.	31,255,255.	31,255,255.	31,255,255.	31,255,255.	31,255,255.	31,255,255.	31,255,255.	31,255,255.	31,255,255.	31,255,255.
3660 DATA	15,252.	0.	47,128.	0.	0.	0.	0.	0.	0.	0.	0.	0.	0.	0.	0.
3670	' 2ND LINE														
3680 DATA	0.	0.	0.	0.	0.	0.	0.	0.	0.	0.	0.	0.	0.	0.	0.
3690 DATA	0.	0.	0.	0.	0.	0.	0.	0.	0.	0.	0.	0.	0.	0.	0.
3700 DATA	0.	0.	0.	0.	0.	0.	0.	0.	0.	0.	0.	0.	0.	0.	0.
3710 DATA	0.	0.	0.	0.	0.	0.	0.	0.	0.	0.	0.	0.	0.	0.	0.

3720 DATA 0, 0, 0, 0, 0, 0, 0, 0, 0, 0, 0, 255, 255, 255, 255, 255, 255
3730 DATA 255, 255, 255, 0, 0, 0, 0, 0, 0, 0, 0, 0, 0, 0, 0, 0, 0
3740 DATA 0, 0, 0, 0, 0, 0, 0, 0, 0, 0, 0, 0, 0, 0, 0, 0
3750 DATA 0, 0, 0, 0, 0, 0, 0, 0, 0, 0, 0, 0, 0, 0, 0, 0
3760 DATA 255, 255, 255, 31, 255, 255, 7, 255, 255, 0, 255, 255, 0, 31, 255
3770 DATA 0, 3, 255, 0, 0, 255, 0, 0, 31, 0, 0, 7, 0, 0, 0, 0
3780 DATA 0, 0, 0, 0, 0, 0, 0, 0, 0, 0, 0, 224, 0, 0, 252, 0, 0
3790 DATA 254, 0, 0, 248, 0, 0, 192, 0, 0, 0, 0, 0, 0, 0, 0, 0
3800 DATA 0, 0, 0, 0, 0, 0, 0, 0, 0, 0, 0, 0, 7, 0, 0, 63
3810 DATA 0, 1, 255, 0, 15, 255, 0, 127, 255, 1, 255, 255, 15, 255, 255
3820 DATA 255, 255, 255, 0, 0, 0, 0, 0, 0, 0, 0, 0, 0, 0, 0, 0
3830 DATA 0, 0, 0, 0, 0, 0, 0, 0, 0, 0, 0, 0, 0, 0, 0, 0
3840 DATA 0, 0, 0, 0, 0, 0, 0, 0, 0, 0, 0, 0, 0, 0, 0, 0
3850 DATA 255, 255, 255, 255, 255, 255, 255, 255, 255, 255, 255, 255, 255, 255, 255
3860 DATA 255, 255, 255, 255, 255, 255, 0, 0, 0, 0, 0, 0, 0, 0, 0, 0
3870 DATA 0, 0, 0, 0, 0, 0, 0, 0, 0, 0, 0, 0, 0, 0, 0, 0
3880 DATA 0, 0, 0, 0, 0, 0, 0, 0, 0, 0, 0, 0, 0, 0, 0, 0
3890 DATA 0, 7, 224, 0, 63, 252, 128, 120, 31, 192, 224, 3, 97, 128, 0
3900 DATA 59, 0, 0, 30, 0, 0, 14, 0, 0, 12, 0, 0, 12, 0, 0
3910 DATA 0, 0, 0, 0, 0, 0, 0, 0, 0, 0, 0, 0, 0, 0, 0, 0
3920 DATA 0, 0, 0, 0, 0, 0, 0, 0, 0, 0, 0, 0, 0, 0, 63, 0
3930 DATA 128, 127, 128, 128, 127, 128, 128, 127, 128, 128, 127, 128, 128, 128, 255, 128
3940 DATA 223, 255, 128, 255, 255, 128, 255, 255, 0, 224, 0, 0, 224, 0, 0
3950 DATA 224, 0, 0, 224, 0, 0, 224, 0, 0, 224, 0, 0, 224, 0, 0
3960 DATA 224, 0, 0, 224, 0, 0, 224, 0, 0, 224, 0, 0, 224, 0, 0
3970 DATA 224, 0, 1, 224, 0, 3, 240, 0, 15, 255, 255, 255, 255, 255, 254
3980 DATA 255, 255, 254, 255, 255, 252, 255, 255, 248, 255, 255, 224, 255, 255, 128
3990 DATA 0, 0, 0, 0, 0, 0, 0, 0, 0, 0, 0, 0, 0, 0, 0, 0
4000 DATA 0, 0, 0, 0, 0, 0, 0, 0, 0, 0, 0, 0, 0, 0, 0, 0
4010 DATA 0, 0, 0, 0, 0, 0, 240, 0, 0, 255, 0, 0, 15, 248, 0
4020 DATA 0, 63, 0, 0, 3, 248, 0, 0, 31, 0, 0, 3, 0, 0, 0, 0
4030 DATA 0, 0, 0, 0, 0, 0, 0, 0, 0, 0, 0, 0, 0, 0, 0, 0
4040 DATA 0, 0, 0, 0, 0, 0, 0, 0, 0, 0, 0, 255, 0, 0, 255, 224, 0
4050 DATA 255, 128, 0, 240, 0, 0, 0, 0, 0, 0, 0, 0, 0, 0, 0, 0
4060 DATA 0, 0, 0, 0, 0, 0, 0, 0, 0, 0, 0, 0, 7, 0, 0, 127
4070 DATA 0, 7, 255, 0, 63, 255, 1, 255, 255, 31, 255, 255, 3, 255, 255
4080 DATA 0, 127, 254, 0, 7, 252, 0, 0, 127, 0, 0, 7, 0, 0, 0
4090 DATA 0, 0, 0, 0, 0, 0, 0, 0, 0, 0, 0, 0, 0, 128, 0, 0
4100 DATA 248, 0, 0, 255, 0, 0, 255, 192, 0, 128, 0, 0, 0, 0, 0, 0
4110 DATA 0, 0, 0, 0, 0, 0, 0, 0, 0, 0, 0, 0, 0, 0, 0, 0
4120 DATA 0, 0, 0, 0, 0, 0, 0, 0, 0, 0, 0, 0, 1, 0, 0, 63
4130 DATA 0, 31, 255, 7, 255, 255, 255, 255, 255, 255, 255, 255, 255, 255, 254
4140 DATA 255, 255, 192, 255, 248, 0, 255, 0, 0, 0, 0, 0, 0, 0, 0, 0
4150 DATA 0, 0, 0, 0, 0, 0, 0, 0, 0, 0, 0, 0, 0, 0, 0, 0
4160 * 3RD LINE
4170 DATA 0, 0, 0, 0, 0, 0, 0, 0, 0, 0, 0, 0, 24, 0, 0, 56
4180 DATA 0, 0, 56, 0, 0, 120, 0, 0, 248, 0, 1, 248, 0, 1, 248
4190 DATA 0, 3, 248, 0, 7, 248, 0, 7, 248, 0, 15, 248, 0, 15, 248
4200 DATA 0, 31, 248, 0, 63, 248, 0, 127, 248, 0, 127, 248, 0, 255, 248
4210 DATA 0, 255, 248, 1, 255, 248, 3, 255, 248, 199, 255, 248, 247, 255, 248
4220 DATA 255, 255, 248, 31, 255, 240, 15, 255, 240, 15, 255, 224, 15, 255, 224
4230 DATA 15, 255, 192, 15, 255, 192, 15, 255, 192, 15, 255, 128, 15, 255, 128

4240 DATA 15,255, 0, 15,255, 0, 15,255, 0, 15,254, 0, 15,254, 0
4250 DATA 252,252, 24,252,252, 56,249,252,248,249,252,248,243,255,248
4260 DATA 227,255,248,231,255,248,199,255,248,231,255,248,255,255,248
4270 DATA 31,255,248, 15,255,248, 15,255,248, 15,255,248, 15,255,248
4280 DATA 15,255,248, 15,255,248, 15,255,248, 15,255,248, 15,207,248
4290 DATA 31, 15,248, 30, 31,248,252, 63,248,248,127,248,240,127,240
4300 DATA 224,255,240,225,255,240,195,255,224,199,255,192,247,255,128
4310 DATA 255,255,128, 63,255, 0, 31,254, 0, 15,254, 0, 15,252, 0
4320 DATA 15,248, 0, 15,240, 0, 15,240, 0, 15,224, 0, 15,192, 0
4330 DATA 15,192, 0, 15,128, 0, 15, 0, 0, 31, 0, 0, 62, 0, 0
4340 DATA 252, 0, 0,252, 0, 0,248, 0, 0,240, 0,224,240, 0,240
4350 DATA 224, 1,240,192, 1,248, 0, 3,248, 0, 3,248, 0, 3,248
4360 DATA 0, 7,248, 0, 7,248, 0, 63,248, 0,127,248, 0,127,248
4370 DATA 0,255,248, 0,255,248, 1,255,248, 1,255,248, 1,255,248
4380 DATA 3,255,248, 3,255,248, 3,255,248,131,255,248,199,255,248
4390 DATA 103,255,248,119,255,248, 55,255,248, 63,255,248, 31,255,248
4400 DATA 31,255,248, 31,255,248, 15,255,248, 15,255,248, 15,255,248
4410 DATA 15,255,248, 15,255,248, 15,255,248, 15,255,248, 15,255,240
4420 DATA 15,255,240, 15,255,224, 15,255,192, 15,255,192, 15,254, 0
4430 DATA 15,254, 0, 15,254, 0, 15,254, 0, 15,254, 0, 15,254, 0
4440 DATA 15,252, 0, 15,252, 0, 15,248, 0, 15,240, 0, 31,240, 0
4450 DATA 31,224, 0, 31,192, 0, 55,128, 0, 48, 0, 8, 96, 0, 24
4460 DATA 192, 0, 24,128, 0, 56, 0, 0, 56, 0, 0,120, 0, 0,120
4470 DATA 0, 0,248, 0, 0,248, 0, 1,248, 0, 1,248, 0, 3,248
4480 DATA 0, 3,248, 0, 7,248, 0, 7,248, 0, 15,248, 0, 15,248
4490 DATA 0, 31,248, 0, 31,240, 0, 63,240, 0, 63,224, 0,127,224
4500 DATA 0,127,192, 0,255,192, 0,255,128, 1,255,128, 1,255, 24
4510 DATA 3,255, 56, 3,255,248,231,255,248,255,255,248, 31,255,248
4520 DATA 15,255,248, 15,255,248, 15,255,248, 15,255,248, 15,255,248
4530 DATA 15,255,248, 15,255,248, 15,255,248, 15,255,248, 15,255,240
4540 DATA 15,255,240, 15,255,240, 15,255,224, 15,255,224, 15,255,192
4550 DATA 15,255,192, 31,255,128,254,127,128,252,127, 24,248,255, 56
4560 DATA 248,255,248,240,255,248,225,255,248,193,255,248,131,255,248
4570 DATA 3,255,248, 7,255,248,135,255,248,231,255,248,255,255,248
4580 DATA 63,255,248, 31,255,248, 15,255,248, 15,255,248, 15,255,240
4590 DATA 15,255,240, 15,255,224, 15,255,192, 15,255,128, 15,255, 0
4600 DATA 15,254, 0, 15,252, 0, 15,248, 0, 15,240, 0, 15,224, 0
4610 DATA 15,192, 0, 15, 0, 0, 62, 0, 0,252, 0, 0,248, 0, 0
4620 DATA 240, 0, 0,224, 0, 0,192, 0, 0,128, 0, 0, 0, 0, 0
4630 DATA 0, 0, 0, 0, 0, 0, 0, 0, 0, 0, 0, 0, 0, 0, 0
4640 DATA 0, 0, 0, 0, 0, 0, 0, 0, 0, 0, 0, 0, 0, 0, 0

How the program works

This program begins by assigning a number of printer commands to BASIC string variables (lines 1000 to 1060). You can find most of these commands near the beginning of chapter 7.

The WIDTH “LPT1:” 255 statement in line 1080 means infinite line width. It prevents the IBM-PC from inserting unwanted carriage returns and line feeds in graphics data.

Actual printing begins in line 1090. Using the preassigned commands, the program prints samples of its different fonts, followed by samples of the print pitches, then some expanded printing.

Next comes the central attraction of the program: a line of text printed fourteen times in expanding and contracting loops to give a barrel effect. The work is done by two printer commands: a command to vary the line spacing (lines 1400 and 1450); and a command to micro-adjust the space between characters (lines 1410 and 1460).

Next the program returns to normal spacing and gives a demonstration of the printer’s word-processing abilities: italic printing, bold printing, underlining, subscripts, etc.

The row of telephone symbols in the next printed line is created by downloading two new character patterns, which are printed in place of the character “<” (character 60). Details can be found in Chapter 9.

The final part of the program uses dot graphics to print an “M & W” logo. The dot pattern of the logo was originally laid out on graph paper, then converted to the data in lines 3180 to 4640 with the help of a calculator. Each number represents eight vertical dots. (See “Graphics commands” in Chapter 8 for details.)

The pattern is printed in three rows, each row is twenty-four dots high and 240 dots wide. Line 1940 sets the line spacing to 8/60 inch so that the rows will connect vertically. The loop in lines 1950 to 2030 does the printing in three passes of the print head.

Chapter 11

REFERENCE

SPECIFICATIONS

Printing system	Serial Impact Dot-matrix		
Printing speed	Pica	Elite	Semi-condensed
Draft	160cps	192cps	240cps
Letter Quality	53cps	64cps	80cps
Print direction	Bi-directional, logic-seeking Uni-directional, logic-seeking (selectable)		
Print head	24 pins		
Life	200 million dots		
Line spacing	1/6, 1/8, <i>n</i> /60, <i>n</i> /180, <i>n</i> /360 inches		
Font styles	Draft, Roman, Sanserif, Courier, Prestige, Script		
Characters	ASCII	96	
	International	16 sets (*)	
	Special	111	
	Block graphic	50	
	Code page	6 sets (**)	
	Download	127	

* USA, France, Germany, England, Denmark I, Sweden, Italy, Spain I, Japan, Norway, Denmark II, Spain II, Latin America, Korea, Irish, Legal

** #437 (USA), #850 (Multi-Lingual), #860 (Portuguese), #861 (Icelandic), #863 (Canadian French), #865 (Nordic)

Number of columns	
Pica (10 CPI)	80
Elite (12 CPI)	96
Semi-condensed (15 CPI)	120
Condensed pica (17 CPI)	137
Condensed elite (20 CPI)	160
Proportional	Variable

Character matrix	Draft	LQ
Pica	24 x 9	24 x 31
Elite	24 x 9	24 x 27
Semi-condensed	16 x 7	16 x 21
Condensed pica	24 x 9	24 x 16
Condensed elite	24 x 9	24 x 16
Proportional	—	24 x <i>n</i>

Bit image dot-matrix

8-pin normal (60 DPI)	8 x 480
8-pin double (120 DPI)	8 x 960
8-pin high-speed double (120 DPI)*	8 x 960
8-pin quadruple (240 DPI)*	8 x 1920
8-pin CRT I (80 DPI)	8 x 640
8-pin CRT II (90 DPI)	8 x 720
24-pin normal (60 DPI)	24 x 480
24-pin double (120 DPI)	24 x 960
24-pin CRT III (90 DPI)	24 x 720
24-pin Triple (180 DPI)	24 x 1440
24-pin Hex (360 DPI)*	24 x 2880

* It is impossible to print adjacent dots in a mode marked with an asterisk (*).

Paper feed Friction or push tractor feed

Paper feed speed 3.4 inches/second max

Paper specifications

Cut sheet

Width	5.5" - 8.5" (139.7 - 215.9 mm)
Length	5.5" - 14.0" (139.7 - 355.6 mm)
Thickness	0.07 - 0.12 mm
Weight	52 - 90 g/m ² , 45 - 77 kg, 14 - 24 lb

Fanfold (continuous)

Width	4.0" - 10.00" (101.6 - 254.0 mm)
Length	Minimum 5.5" (139.7 mm)
Thickness	Single-ply paper 0.07 - 0.12 mm Total for multi-part forms 0.25 mm
Weight	52 - 82 g/m ² , 45 - 70 kg, 14 - 22 lb
Copies	Original + 2 copies

Maximum buffer size	Without Download 16kB With Download 256Bytes
Emulations	Epson LQ-860/850, NEC 24-wire Graphics commands
Interface	Centronics parallel (standard) RS-232C serial (option)
Ribbon type	On-carriage, dedicated Fabric ribbon (Black only)
Ribbon life	
Fabric ribbon (Z24)	2 million characters (draft pica)
Long life fabric ribbon (LZ24HD)	4 million characters (draft pica)
Dimensions and Weight	
Width	410 mm (16.14")
Depth	328 mm (12.91")
Height	121 mm (4.76")
Weight	6.5 kg (14.3 lb)
Power supply	120VAC, 220VAC, 230VAC, 240VAC, 50/60 Hz (varies according to the contry of purchase)
Options	Long life fabric ribbon cartridge (LZ24HD) Single-bin Automatic Sheet Feeder (SF-10DV) Serial-Parallel Converter (SPC-8K)

PINOUT OF INTERFACE CONNECTOR

The following describes the pinout of the interface connector (signals which are low when active are overlined).

Parallel interface

Pin	Name	Function
1	<u>STROBE</u>	Goes from high to low (for $\geq 0.5 \mu\text{s}$) when active
2	DATA 0	High when active
3	DATA 1	High when active
4	DATA 2	High when active
5	DATA 3	High when active
6	DATA 4	High when active
7	DATA 5	High when active
8	DATA 6	High when active
9	DATA 7	High when active
10	<u>ACK</u>	5 μs low pulse acknowledges receipt of data
11	BUSY	Low when printer ready to receive data
12	PAPER	High when paper out. Can be disabled with EDS setting
13	SELECT	High when printer is on-line
14 - 15	N/C	
16	SIGNAL GND	Signal ground
17	CHASSIS	Chassis ground (isolated from signal ground)
18	+5V	+5V DC output from printer
19 - 30	GND	Twisted pair ground return
31	<u>RESET</u>	When this input signal is low, printer is reset
32	<u>ERROR</u>	Outputs low when printer cannot continue, due to an error
33	EXT GND	External ground
34 - 35	N/C	
36	<u>SELECT IN</u>	Always high

Serial Interface

Pin	Name	Function
1	GND	Printer's chassis ground.
2	TXD	This pin carries data from the printer
3	RXD	This pin carries data to the printer
4	RTS	This pin is always set to Space
5	CTS	This pin is Space when the computer is ready to send data. This printer does not check this pin
6	N/C	
7	GND	Signal ground
8 - 10	N/C	
11	RCH	This printer turns this pin to Space when it is ready to receive data. This line carries the same signal as pin 20
12	N/C	
13	GND	Signal ground
14 - 19	N/C	
20	DTR	This printer turns this pin to Space when it is ready to receive data
21 - 25	N/C	

CHARACTER SETS

The following tables show the Italic and Graphics character sets.

The decimal character code of each character is shown in an inset to the lower right of the character.

The hexadecimal code can be found by reading the entries at the top and left edges of the table. For example, the character "A" is in column 4 and row 1, so its hexadecimal character code is 41. This is equivalent ($4 \times 16 + 1 = 65$) to decimal 65, the number in the inset.

Control codes recognized by this printer are indicated by abbreviations inside pointed brackets $\langle \rangle$.

The numbers above the decimal character code shows the proportional width of character.

The values given are in 360ths of an inch. For example, a value of 36 is 36/360ths of an inch. You may need to enter these widths into a special table for your processing program so it can calculate the number of proportional characters that will fit on a line.

	0	1	2	3	4	5	6	7
0	$\langle \text{NUL} \rangle$		30	0 30	@ 36	P 36	` 18	p 36
	0	16	32	48	64	80	96	112
1		$\langle \text{DC1} \rangle$! 18	1 30	A 36	Q 36	a 30	q 36
	1	17	33	49	65	81	97	113
2		$\langle \text{DC2} \rangle$	" 30	2 30	B 36	R 36	b 36	r 30
	2	18	34	50	66	82	98	114
3		$\langle \text{DC3} \rangle$	# 30	3 30	C 36	S 36	c 30	s 30
	3				67	83	99	115
"						36	d 36	t 24
							100	116

Hexadecimal value (low order)

Hexadecimal value (high order)

Character

Proportional width

Decimal value

Control code

Italic character set #2

	0	1	2	3	4	5	6	7
0	<NUL> 0	16	30 32	0 30 48	@ 36 64	P 36 80	` 18 96	p 36 112
1	1	<DC1> 17	! 18 33	1 30 49	A 36 65	Q 36 81	a 30 97	q 36 113
2	2	<DC2> 18	" 30 34	2 30 50	B 36 66	R 36 82	b 36 98	r 30 114
3	3	<DC3> 19	# 30 35	3 30 51	C 36 67	S 36 83	c 30 99	s 30 115
4	4	<DC4> 20	\$ 30 36	4 30 52	D 36 68	T 36 84	d 36 100	t 24 116
5	5	21	% 36 37	5 30 53	E 36 69	U 42 85	e 30 101	u 36 117
6	6	22	& 36 38	6 30 54	F 36 70	V 36 86	f 24 102	v 36 118
7	<BEL> 7	23	' 18 39	7 30 55	G 36 71	W 42 87	g 36 103	w 42 119
8	<BS> 8	<CAN> 24	(24 40	8 30 56	H 36 72	X 36 88	h 36 104	x 30 120
9	<HT> 9	 25) 24 41	9 30 57	I 24 73	Y 36 89	i 18 105	y 36 121
A	<LF> 10	26	* 30 42	: 18 58	J 30 74	Z 30 90	j 24 106	z 30 122
B	<VT> 11	<ESC> 27	+ 30 43	; 18 59	K 36 75	[24 91	k 36 107	{ 24 123
C	<FF> 12	<FS> 28	, 18 44	< 30 60	L 36 76	\ 30 92	l 18 108	18 124
D	<CR> 13	29	- 30 45	= 30 61	M 42 77] 24 93	m 42 109	} 24 125
E	<SO> 14	30	. 18 46	> 30 62	N 36 78	^ 30 94	n 36 110	~ 30 126
F	<SI> 15	31	/ 30 47	? 30 63	O 36 79	_ 30 95	o 30 111	 127

	8	9	A	B	C	D	E	F
0	à 30 128	§ 30 144	30 160	0 30 176	@ 36 192	P 36 208	` 18 224	p 36 240
1	è 30 129	ß 36 145	! 18 161	1 30 177	A 36 193	Q 36 209	a 30 225	q 36 241
2	ù 36 130	Æ 42 146	" 30 162	2 30 178	B 36 194	R 36 210	b 36 226	r 30 242
3	ò 30 131	æ 42 147	# 30 163	3 30 179	C 36 195	S 36 211	c 30 227	s 30 243
4	ì 18 132	Ø 36 148	\$ 30 164	4 30 180	D 36 196	T 36 212	d 36 228	t 24 244
5	° 24 133	∅ 30 149	% 36 165	5 30 181	E 36 197	U 42 213	e 30 229	u 36 245
6	£ 30 134	° 30 150	& 36 166	6 30 182	F 36 198	V 36 214	f 24 230	v 36 246
7	í 30 135	Å 36 151	' 18 167	7 30 183	G 36 199	W 42 215	g 36 231	w 42 247
8	ï 30 136	Ö 36 152	(24 168	8 30 184	H 36 200	X 36 216	h 36 232	x 30 248
9	Ë 36 137	Û 42 153) 24 169	9 30 185	I 24 201	Y 36 217	i 18 233	y 36 249
A	ñ 36 138	ä 30 154	* 30 170	: 18 186	J 30 202	Z 30 218	j 24 234	z 30 250
B	π 30 139	ö 30 155	+ 30 171	; 18 187	K 36 203	[24 219	k 36 235	{ 24 251
C	Ř 42 140	ü 36 156	, 18 172	< 30 188	L 36 204	\ 30 220	l 18 236	! 18 252
D	Á 36 141	É 36 157	- 30 173	= 30 189	M 42 205] 24 221	m 42 237	} 24 253
E	á 30 142	é 30 158	. 18 174	> 30 190	N 36 206	^ 30 222	n 36 238	~ 30 254
F	ç 30 143	¥ 36 159	/ 30 175	? 30 191	O 36 207	- 30 223	o 30 239	

International character sets

When an international character set is selected by a command from software, the following changes are made in the Italic character set:

Country	35	36	64	88	90	91	92	93	94	96	123	124	125	126
U.S.A.	#	\$	@	X	Z	[\]	^	`	{		}	~
FRANCE	#	\$	à	X	Z	°	ç	§	^	`	é	ù	è	¨
GERMANY	#	\$	§	X	Z	À	Ö	Ü	^	`	ä	ö	ü	ß
ENGLAND	£	\$	@	X	Z	[\]	^	`	{		}	~
DENMARK 1	#	\$	@	X	Z	Æ	Ø	Å	^	`	æ	ø	å	~
SWEDEN	#	¤	É	X	Z	À	Ö	Å	Ü	é	ä	ö	å	ü
ITALY	#	\$	@	X	Z	°	\	é	^	ù	à	ò	è	ì
SPAIN 1	₧	\$	@	X	Z	ı	Ñ	¿	^	´	¨	ñ	}	~
JAPAN	#	\$	@	X	Z	[¥]	^	`	{		}	~
NORWAY	#	¤	É	X	Z	Æ	Ø	Å	Ü	é	æ	ø	å	ü
DENMARK 2	#	\$	É	X	Z	Æ	Ø	Å	Ü	é	æ	ø	å	ü
SPAIN 2	#	\$	á	X	Z	ı	Ñ	¿	é	´	ı	ñ	ó	ú
LATIN AMERICA	#	\$	á	X	Z	ı	Ñ	¿	é	ü	ı	ñ	ó	ú
KOREA	#	\$	@	X	Z	[₩]	^	`	{		}	~
IRISH	#	\$	@	Ú	ˊ	[\]	^	`	Á	É	Ó	~
LEGAL	#	\$	§	X	Z	°	'	"	¶	`	©	®	†	™

The command for selecting the international character set is:

<ESC> "R" *n*

Where *n* means character code *n*, i. e. CHR\$(*n*) in BASIC. The values of *n* are:

0 U.S.A.	6 Italy	12 Latin America
1 France	7 Spain I	13 Korea
2 Germany	8 Japan	14 Irish
3 England	9 Norway	64 Legal
4 Denmark I	10 Denmark II	
5 Sweden	11 Spain II	

Graphics character set #2

Code Page #437 (U.S.A.)

	0	1	2	3	4	5	6	7
0	<NUL> 0 16 32 48 64 80 96 112		30	0 30	@ 36	P 36	` 18	p 36
1	<DC1> 1 17 33 49 65 81 97 113	!	18	1 30	A 36	Q 36	a 30	q 36
2	<DC2> 2 18 34 50 66 82 98 114	"	30	2 30	B 36	R 36	b 36	r 30
3	♥ <DC3> 3 19 35 51 67 83 99 115	#	30	3 30	C 36	S 36	c 30	s 30
4	♦ <DC4> 4 20 36 52 68 84 100 116	\$	30	4 30	D 36	T 36	d 36	t 24
5	♣ § 5 21 37 53 69 85 101 117	%	36	5 30	E 36	U 42	e 30	u 36
6	♠ 6 22 38 54 70 86 102 118	&	36	6 30	F 36	V 36	f 24	v 36
7	<BEL> 7 23 39 55 71 87 103 119	'	18	7 30	G 36	W 42	g 36	w 42
8	<BS> <CAN> 8 24 40 56 72 88 104 120	(24	8 30	H 36	X 36	h 36	x 30
9	<HT> 9 25 41 57 73 89 105 121)	24	9 30	I 24	Y 36	i 18	y 36
A	<LF> 10 26 42 58 74 90 106 122	*	30	: 18	J 30	Z 30	j 24	z 30
B	<VT> <ESC> 11 27 43 59 75 91 107 123	+	30	; 18	K 36	[24	k 36	{ 24
C	<FF> <FS> 12 28 44 60 76 92 108 124	,	18	< 30	L 36	\ 30	l 18	! 18
D	<CR> 13 29 45 61 77 93 109 125	-	30	= 30	M 42] 24	m 42	} 24
E	<SO> 14 30 46 62 78 94 110 126	.	18	> 30	N 36	^ 30	n 36	~ 30
F	<SI> 15 31 47 63 79 95 111 127	/	30	? 30	O 36	_ 30	o 30	

	B	9	A	B	C	D	E	F
0	Ç 36 128	É 36 144	á 30 160	☼ 30 176	L 30 192	⋈ 30 208	α 30 224	≡ 30 240
1	ü 36 129	æ 42 145	í 18 161	☼ 30 177	⊥ 30 193	⊖ 30 209	β 30 225	± 30 241
2	é 30 130	Æ 42 146	ó 30 162	☼ 30 178	⊥ 30 194	π 30 210	Γ 30 226	≥ 30 242
3	â 30 131	ô 30 147	ú 36 163	30 179	† 30 195	⋈ 30 211	π 30 227	≤ 30 243
4	ä 30 132	ö 30 148	ñ 36 164	† 30 180	- 30 196	⋈ 30 212	Σ 30 228	∫ 30 244
5	à 30 133	ò 30 149	Ñ 36 165	‡ 30 181	† 30 197	F 30 213	σ 30 229	J 30 245
6	â 30 134	û 36 150	ä 30 166	30 182	F 30 198	π 30 214	μ 30 230	÷ 30 246
7	ç 30 135	ù 36 151	ó 30 167	π 30 183	30 199	‡ 30 215	τ 30 231	≈ 30 247
8	ê 30 136	ÿ 36 152	¿ 30 168	ƒ 30 184	⋈ 30 200	≠ 30 216	Φ 30 232	° 30 248
9	ë 30 137	ÿ 36 153	ƒ 30 169	30 185	π 30 201	∩ 30 217	θ 30 233	• 30 249
A	è 30 138	ÿ 42 154	ƒ 30 170	30 186	⋈ 30 202	∩ 30 218	Ω 30 234	• 30 250
B	ï 18 139	ϕ 30 155	½ 30 171	π 30 187	π 30 203	■ 30 219	δ 30 235	√ 30 251
C	î 18 140	£ 30 156	¼ 30 172	⋈ 30 188	30 204	■ 30 220	∞ 30 236	n 30 252
D	ì 18 141	¥ 36 157	¡ 30 173	⋈ 30 189	= 30 205	■ 30 221	∅ 30 237	² 30 253
E	Ë 36 142	ƒ 42 158	« 30 174	‡ 30 190	⋈ 30 206	■ 30 222	€ 30 238	■ 30 254
F	À 36 143	f 30 159	» 30 175	∩ 30 191	⋈ 30 207	■ 30 223	∩ 30 239	

Code Page #850 (Mulch-lingual)

Other characters are identical to Code Page #437.

	B	9	A	B	C	D	E	F
0	Ç 36 128	É 36 144	á 30 160	☼ 30 176	L 30 192	ö 36 208	ó 30 224	- 30 240
1	ü 36 129	æ 42 145	í 18 161	☼ 30 177	⊥ 30 193	Ð 42 209	β 30 225	± 30 241
2	é 30 130	Æ 42 146	ó 30 162	☼ 30 178	⊥ 30 194	È 36 210	ò 30 226	= 30 242
3	â 30 131	ô 30 147	ú 36 163	30 179	† 30 195	È 36 211	ö 30 227	¾ 30 243
4	ä 30 132	ö 30 148	ñ 36 164	† 30 180	- 30 196	È 36 212	ö 30 228	¶ 30 244
5	à 30 133	ò 30 149	ñ 36 165	À 36 181	† 30 197	ı 18 213	ö 30 229	§ 30 245
6	â 30 134	û 36 150	æ 30 166	À 42 182	ã 30 198	ı 24 214	μ 30 230	÷ 30 246
7	ç 30 135	ù 36 151	o 30 167	À 42 183	Ä 42 199	ı 24 215	þ 30 231	˙ 30 247
8	ê 30 136	ÿ 36 152	ı 30 168	© 36 184	Ł 30 200	Ÿ 24 216	þ 30 232	° 30 248
9	ë 30 137	ö 36 153	• 36 169	¶ 30 185	ŕ 30 201	Ĵ 30 217	Ů 30 233	¨ 30 249
A	è 30 138	Û 42 154	¬ 30 170	30 186	Ł 30 202	ŕ 30 218	Ů 30 234	˙ 30 250
B	ï 18 139	ø 30 155	½ 30 171	¶ 30 187	ŕ 30 203	■ 30 219	Ů 30 235	ı 30 251
C	î 18 140	£ 30 156	¾ 30 172	¶ 30 188	ŕ 30 204	■ 30 220	ý 30 236	³ 30 252
D	ı 18 141	Ø 36 157	ı 30 173	¢ 30 189	= 30 205	ı 18 221	Ÿ 30 237	² 30 253
E	Ä 36 142	× 42 158	« 30 174	¥ 36 190	¶ 30 206	ı 24 222	- 30 238	■ 30 254
F	Å 36 143	f 30 159	» 30 175	ŕ 30 191	α 30 207	■ 30 223	' 18 239	

Code Page #860 (Portuguese)

Other characters are identical to Code Page #437.

	8	9	A	B	C	D	E	F
0	Ç 36 128	É 36 144	Á 30 160	◌̣ 30 176	Ł 30 192	Ł 30 208	α 30 224	≡ 30 240
1	Û 36 129	À 42 145	Í 18 161	◌̣ 30 177	⊥ 30 193	⊥ 30 209	β 30 225	± 30 241
2	é 30 130	Ê 36 146	Ó 30 162	◌̣ 30 178	⊥ 30 194	π 30 210	Γ 30 226	≥ 30 242
3	â 30 131	Ô 30 147	Ú 36 163	30 179	† 30 195	μ 30 211	π 30 227	≤ 30 243
4	ã 30 132	Õ 30 148	Ñ 36 164	† 30 180	- 30 196	Ł 30 212	Σ 30 228	∫ 30 244
5	à 30 133	Ò 30 149	Ñ 36 165	‡ 30 181	† 30 197	ƒ 30 213	σ 30 229	∫ 30 245
6	Á 36 134	Û 30 150	â 30 166	‡ 30 182	ƒ 30 198	π 30 214	μ 30 230	÷ 30 246
7	ç 30 135	Û 36 151	ô 30 167	π 30 183	‡ 30 199	‡ 30 215	τ 30 231	≈ 30 247
8	ê 30 136	Ï 24 152	¿ 30 168	ƒ 30 184	Ł 30 200	‡ 30 216	Φ 30 232	° 30 248
9	Ê 36 137	Ö 30 153	Ò 30 169	‡ 30 185	ƒ 30 201	∫ 30 217	Θ 30 233	• 30 249
A	è 30 138	Û 42 154	¬ 30 170	‡ 30 186	Ł 30 202	ƒ 30 218	Ω 30 234	• 30 250
B	í 24 139	ϕ 30 155	½ 30 171	π 30 187	π 30 203	■ 30 219	δ 30 235	√ 30 251
C	ó 30 140	£ 30 156	¾ 30 172	∩ 30 188	∩ 30 204	■ 30 220	∞ 30 236	n 30 252
D	ì 18 141	Û 30 157	î 30 173	μ 30 189	= 30 205	■ 30 221	∅ 30 237	² 30 253
E	Ā 42 142	Ř 42 158	« 30 174	∩ 30 190	∩ 30 206	■ 30 222	€ 30 238	■ 30 254
F	Ā 42 143	Ó 30 159	» 30 175	∩ 30 191	± 30 207	■ 30 223	∩ 30 239	

Code Page #861 (Icelandic)

Other characters are identical to Code Page #437.

	8	9	A	B	C	D	E	F
0	Ç 36 128	É 36 144	á 30 160	ð 30 176	Ł 30 192	ll 30 208	α 30 224	≡ 30 240
1	ü 36 129	æ 42 145	í 18 161	ð 30 177	Ł 30 193	ƒ 30 209	β 30 225	± 30 241
2	é 30 130	Æ 42 146	ó 30 162	ð 30 178	ƒ 30 194	π 30 210	Γ 30 226	≥ 30 242
3	â 30 131	ô 30 147	ú 36 163	30 179	† 30 195	ll 30 211	π 30 227	≤ 30 243
4	ä 30 132	ö 30 148	Á 36 164	† 30 180	– 30 196	Ł 30 212	Σ 30 228	∫ 30 244
5	à 30 133	þ 30 149	Í 24 165	ƒ 30 181	† 30 197	F 30 213	σ 30 229	J 30 245
6	á 30 134	û 36 150	ó 30 166	ll 30 182	ƒ 30 198	π 30 214	μ 30 230	+ 30 246
7	ç 30 135	ÿ 30 151	ú 30 167	π 30 183	† 30 199	## 30 215	τ 30 231	≈ 30 247
8	ê 30 136	ý 30 152	ı 30 168	ƒ 30 184	Ł 30 200	≠ 30 216	Φ 30 232	° 30 248
9	ë 30 137	ö 36 153	ƒ 30 169	ll 30 185	ƒ 30 201	J 30 217	θ 30 233	• 30 249
A	è 30 138	Û 42 154	˘ 30 170	ll 30 186	ll 30 202	ƒ 30 218	Ω 30 234	• 30 250
B	Ð 42 139	ø 30 155	½ 30 171	π 30 187	π 30 203	■ 30 219	δ 30 235	√ 30 251
C	ð 36 140	£ 30 156	¼ 30 172	ll 30 188	ll 30 204	■ 30 220	∞ 30 236	n 30 252
D	þ 30 141	Ø 36 157	ı 30 173	ll 30 189	= 30 205	■ 30 221	ø 30 237	² 30 253
E	Ä 36 142	Ð 42 158	« 30 174	ƒ 30 190	ll 30 206	■ 30 222	€ 30 238	■ 30 254
F	À 36 143	f 30 159	» 30 175	ƒ 30 191	± 30 207	■ 30 223	∩ 30 239	

Code Page #863 (Canadian French)

Other characters are identical to Code Page #437.

	8	9	A	B	C	D	E	F
0	Ç 36 128	É 36 144	Ï 18 160	Û 30 176	Ł 30 192	Ů 30 208	α 30 224	≡ 30 240
1	Û 36 129	Ê 36 145	Ë 18 161	Ü 30 177	Ł 30 193	Ů 30 209	β 30 225	± 30 241
2	É 30 130	Ê 36 146	Ó 30 162	Ü 30 178	Ť 30 194	Π 30 210	Γ 30 226	≥ 30 242
3	Â 30 131	Ô 30 147	Ú 36 163	Ï 30 179	Ŧ 30 195	Ů 30 211	π 30 227	≤ 30 243
4	À 42 132	Ë 36 148	Û 30 164	Ŧ 30 180	– 30 196	Ł 30 212	Σ 30 228	ƒ 30 244
5	À 30 133	Ï 24 149	Û 30 165	Ŧ 30 181	† 30 197	ƒ 30 213	σ 30 229	Ƶ 30 245
6	Ŧ 30 134	Û 36 150	³ 30 166	Ŧ 30 182	Ŧ 30 198	π 30 214	μ 30 230	+ 30 246
7	Ç 30 135	Û 36 151	– 30 167	π 30 183	Ŧ 30 199	Ŧ 30 215	τ 30 231	≈ 30 247
8	É 30 136	α 30 152	† 24 168	Ŧ 30 184	Ł 30 200	† 30 216	Φ 30 232	° 30 248
9	Ë 30 137	Ó 30 153	Ŧ 30 169	Ŧ 30 185	Ŧ 30 201	Ƶ 30 217	Θ 30 233	• 30 249
A	È 30 138	Û 42 154	Ŧ 30 170	Ŧ 30 186	Ł 30 202	Ŧ 30 218	Ω 30 234	• 30 250
B	Ï 18 139	Φ 30 155	½ 30 171	Ŧ 30 187	Ŧ 30 203	■ 30 219	δ 30 235	√ 30 251
C	Î 18 140	£ 30 156	¼ 30 172	Ƶ 30 188	Ŧ 30 204	■ 30 220	∞ 30 236	n 30 252
D	= 30 141	Û 30 157	¾ 30 173	Ů 30 189	= 30 205	■ 30 221	∅ 30 237	² 30 253
E	À 42 142	Û 30 158	« 30 174	Ƶ 30 190	Ŧ 30 206	■ 30 222	€ 30 238	■ 30 254
F	§ 30 143	f 30 159	» 30 175	Ŧ 30 191	± 30 207	■ 30 223	∩ 30 239	

Code Page #865 (Nordic)

Other characters are identical to Code Page #437.

	8	9	A	B	C	D	E	F
0	Ç 36 128	Ð 36 144	á 30 160	•••• 30 176	L 30 192	ll 30 208	α 30 224	≡ 30 240
1	ú 36 129	æ 42 145	í 18 161	•••• 30 177	⊥ 30 193	⌞ 30 209	β 30 225	± 30 241
2	é 30 130	Æ 42 146	ó 30 162	•••• 30 178	T 30 194	π 30 210	Γ 30 226	≥ 30 242
3	â 30 131	ô 30 147	û 36 163	30 179	† 30 195	ll 30 211	π 30 227	≤ 30 243
4	ä 30 132	ö 30 148	ñ 36 164	† 30 180	- 30 196	ℓ 30 212	Σ 30 228	∫ 30 244
5	à 30 133	ò 30 149	Ñ 36 165	‡ 30 181	† 30 197	F 30 213	σ 30 229	J 30 245
6	á 30 134	û 36 150	ä 30 166	30 182	‡ 30 198	π 30 214	μ 30 230	+ 30 246
7	ç 30 135	ù 36 151	o 30 167	π 30 183	30 199	## 30 215	τ 30 231	≈ 30 247
8	ê 30 136	ÿ 36 152	¿ 30 168	ƒ 30 184	ll 30 200	≠ 30 216	Φ 30 232	° 30 248
9	ë 30 137	ö 36 153	ƒ 30 169	30 185	ll 30 201	J 30 217	θ 30 233	• 30 249
A	è 30 138	Û 42 154	¬ 30 170	30 186	ll 30 202	ƒ 30 218	Ω 30 234	• 30 250
B	ï 18 139	ø 30 155	½ 30 171	30 187	π 30 203	■ 30 219	δ 30 235	√ 30 251
C	î 18 140	£ 30 156	¼ 30 172	30 188	30 204	■ 30 220	∞ 30 236	n 30 252
D	ì 18 141	Ø 36 157	ì 30 173	ll 30 189	= 30 205	■ 30 221	ø 30 237	² 30 253
E	Ä 36 142	ß 42 158	« 30 174	‡ 30 190	ll 30 206	■ 30 222	€ 30 238	■ 30 254
F	Å 36 143	f 30 159	α 30 175	† 30 191	± 30 207	■ 30 223	∩ 30 239	

Character set #1

Other characters are identical to character set #2.

The duplication of control codes enables systems with a 7-bit interface to obtain control functions when the most significant bit is set to 1 by the <ESC> “>” command.

	0	1
0	<NUL> 0	16
1	1	<DC1> 17
2	2	<DC2> 18
3	3	<DC3> 19
4	4	<DC4> 20
5	5	21
6	6	22
7	<BEL> 7	23
8	<BS> 8	<CAN> 24
9	<HT> 9	 25
A	<LF> 10	26
B	<VT> 11	<ESC> 27
C	<FF> 12	<FS> 28
D	<CR> 13	29
E	<SO> 14	30
F	<SI> 15	31

	8	9
0	<NUL> 128	144
1	129	<DC1> 145
2	130	<DC2> 146
3	131	<DC3> 147
4	132	<DC4> 148
5	133	149
6	134	150
7	<BEL> 135	151
8	<BS> 136	<CAN> 152
9	<HT> 137	 153
A	<LF> 138	154
B	<VT> 139	<ESC> 155
C	<FF> 140	<FS> 156
D	<CR> 141	157
E	<SO> 142	158
F	<SI> 143	159

MEMO

INDEX

A

Absolute horizontal tab, 79
Adjustment lever, 3, 18
All reset, 37
Application software, 15
ASF control commands, 87
Auto Line Feed, 43
Auto loading position, 37, 44
Automatic Sheet Feeder, 8, 43, 53-58

B

Backspace, 78
Bail lever, 3, 22, 26
Beep tones, 39
Bell command, 86
Bi-directional printing, 43, 86
Bit image dot-matrix, 106
Bottom margin, 74
Buffer size, 43, 107
Button and indicator functions, 27-29

C

Cancel command, 85
Carriage centering, 45
Carriage return, 78
Carton contents, 8
CDM, 5
Character data, 90
Character matrix, 89, 91, 106
Character pitch commands, 68-71
Character set #1, 67, 121
Character set #2, 67
Character set commands, 66-67
Character set table, 110-121
Character size commands, 68-71
Character space, 91

Character spacing, 4, 71
Character table, 44, 110-121
Character width, 70
Clamp lever, 3, 20
Clear the buffer, 37
Code page, 45, 105, 114-120
 #437, 114-115
 #850, 116
 #860, 117
 #861, 118
 #863, 119
 #865, 120
Command summary, 127-128
Component, 2-3
Compressed Data Mode, 5
Condensed printing, 69
Contents of the carton, 8
Control commands, 61-88
Control panel, 3, 4, 27-38
Copy characters, 84

D

Default settings, 41-46
Define download characters, 83, 89-93
Delete command, 85
Dimensions, 107
DOS commands, 95
Dot Adjustment mode, 32
Double-density graphics, 80
Double-height characters, 71
Double-strike printing, 63
Download, 43, 83-84, 89-93
Download character commands, 83-84
Download character set, 84
Download characters, 89-93, 105
Draft, 1, 29, 44, 62, 105

E

EDS mode, 5, 15, 41-46
EDS setting, 41-46
Electronic DIP Switch mode, 5, 15, 41-46
Elite pitch, 68
Emphasized printing, 63
Emulation, 15, 107
Entry slot, 3
Expanded printing, 69

F

Factory settings, 42
Fanfold forms, 1, 17, 19-24, 106
Fanfold forms, loading, 19-24
Fanfold forms, paper path, 19
Features, 4-5
Font, 1, 62, 105
FONT button, 29
Font control commands, 62-65
Font lock mode, 4, 32
Font selection, 46
Font style, 1, 62, 105
Font style commands, 62-65
Form feed, 35, 75
Forward feed, 73
Forward micro-feed, 36
Friction feed, 25-26, 106
Front cover, 3, 10, 12

G

Graphics character set, 67, 114-120
Graphics commands, 80-82
Graphics direction, 43
Graphics mode, 81
Graphics printing, 4

H

Hex-density graphics, 81
Hexadecimal dump, 34
Horizontal position commands, 77-79
Horizontal tab, 78, 79

Horizontal tab stops, 78

I

Interface, 107, 108-109
Interface connector, 3, 13
Interface converter, 8, 59-60
International character set, 45, 67, 105, 113
Italic character set, 66, 111-112
Italic characters, 62

L

Left margin, 77
Letter Quality, 4, 29, 44, 46, 62, 105
Line feed, 73
Line spacing, 72, 105
Loading fanfold forms, 19-22
Loading single sheets, 25-26, 57-58
Locating the printer, 7
Long test mode, 31
LQ, 4, 29, 44, 46, 62, 105

M

Macro definition, 38
Maintenance, 52
Master print mode, 70
Most significant bit, 85
MS-DOS, 95
MSB, 85
Multi-part forms, 1, 5, 17

N

Normal-density graphics, 80
Number of columns, 105

O

Off line command, 86
ON LINE button, 28
On line command, 86
One-time line feed, 74
One-time reverse feed, 74
Optional accessories, 8, 53-60, 107

Ornament character, 64
Other printer commands, 85-88
Overlining, 64

P

Page length, 44, 74
Paper feed, 106
PAPER FEED button, 28
Paper feed speed, 106
Paper feed trouble, 48
Paper guide, 3, 13
Paper parking, 1, 5, 22, 35
Paper path
 Fanfold forms, 19
 Single sheets, 25
Paper specifications, 106
Paper-out detector, 43
Pica pitch, 68
Pinout of interface connector, 108-109
PITCH button, 29
Pitch commands, 68-71
Pitch lock mode, 4, 32
Platen knob, 3, 9
Power supply trouble, 47
Power switch, 3
Print area, 17, 44
Print direction, 86, 105
Print head, 3, 105
Print head shield, 11
Print mode, 44
Print quality, 62
Print styles, 6
Printer features, 4-5
Printer initialize, 37
Printer placement, 7
Printing gap, 18
Printing speed, 4, 105
Printing trouble, 47-52
Proportional spacing, 69

Q

Quadruple-density graphics, 81
Quiet mode, 4, 28

R

RAM usage, 43
Rear cover, 3, 20
Relative horizontal tab, 79
Release lever, 3, 20, 26
Reset printer, 37, 88
Reverse feed, 73
Reverse line feed, 73
Reverse micro-feed, 36
Ribbon cartridge, 3, 5, 11, 107
Right margin, 77

S

Sample program, 91-93, 98-103
Score, 64
Selection of paper, 17
Self-test, 30, 31
Semi-condensed, 68
Serial-Parallel Converter, 8, 59-60
Setting up, 9-15
Shift download character area, 84
Short test mode, 30
Single sheets, 1, 17, 25-26, 106
Specifications, 105-107
Strike-through, 64
Subscript, 65
Superscript, 65
Switch combination functions, 35-38

T

Tear assist, 10
Tear-off function, 5, 24
Top of form, 36, 74
Tractor, 3
Troubleshooting, 47-52

U

Underlining, 64

Uni-directional printing, 43, 86

Unpacking and inspection, 8

V

Vertical position commands, 72-76

Vertical tab, 76

Vertical tab channel, 75

Vertical tab stops, 75

W

Weight, 107

COMMAND SUMMARY

The following commands take effect with this printer.

Control code	Function	Page
<BEL>	Bell	86
<BS>	Backspace	78
<HT>	Horizontal tab	78
<LF>	Line feed	73
<VT>	Vertical tab	76
<FF>	Form feed	75
<CR>	Carriage return	78
<SO>	Expanded printing for one line	69
<SI>	Condensed printing	68
<DC1>	Set printer on-line	86
<DC2>	Cancel condensed printing	69
<DC3>	Set printer off-line	86
<DC4>	Cancel one-line expanded printing	70
<CAN>	Cancel last line	85
<ESC> <LF>	Reverse line feed	73
<ESC> <SO>	Expanded printing for one line	69
<ESC> <SI>	Condensed printing	68
<ESC> <0>	Manual feed	87
<ESC> <4>	Auto feed	87
<ESC> "R"	Eject paper from ASF	87
<ESC> "T" <i>n</i>	Set print start position on ASF	87
<ESC> <SP> <i>n</i>	Increase character spacing	71
<ESC> "!" <i>n</i>	Select master print mode	70
<ESC> "#"	Accept MSB as is	85
<ESC> "\$" <i>n1 n2</i>	Absolute horizontal tab in inches	79
<ESC> "%" 0	Select ROM character set	84
<ESC> "%" 1	Select download character set	84
<ESC> "&" <0> <i>n1 n2 m0 m1 m2 d1 d2 ... dx</i>	Define download characters	83
<ESC> "(" "-" <3> <0> <1> <i>n1 n2</i>	Select score	64
<ESC> "(" "t" <3> <0> <i>n1 n2 <0></i>	Assign character set	66
<ESC> "*" <i>n0 n1 n2 m1 m2 ...</i>	Select graphics mode	82
<ESC> "+" <i>n</i>	Set line spacing to <i>n/360</i> inch	72
<ESC> "-" <i>n</i>	Underlining	64
<ESC> "f" <i>n0</i>	Select vertical tab channel	76
<ESC> "0"	Set line spacing to 1/8 inch	72
<ESC> "2"	Set line spacing to 1/6 inch	72
<ESC> "3" <i>n</i>	Set line spacing to <i>n/180</i> inch	72
<ESC> "4"	Select italic characters	62
<ESC> "5"	Select upright characters	63
<ESC> "6"	Select character set #2	67
<ESC> "7"	Select character set #1	67
<ESC> ":" <0> <i>n <0></i>	Copy character set from ROM into RAM	84
<ESC> "<"	One-line uni-directional printing	87
<ESC> "="	Set MSB to 0	85
<ESC> ">"	Set MSB to 1	85
<ESC> "?" <i>n m</i>	Convert graphics density	82
<ESC> "@"	Reset printer	88
<ESC> "A" <i>n</i>	Set line spacing to <i>n/60</i> inch	73
<ESC> "B" <i>n1 n2 ... <0></i>	Set vertical tab stops	75
<ESC> "C" <0> <i>n</i>	Set page length to <i>n</i> inches	74
<ESC> "C" <i>n</i>	Set page length to <i>n</i> lines	74

Control code	Function	Page
<ESC> "D" <i>n1 n2 ...</i> <0>	Set horizontal tab stops	78
<ESC> "E"	Emphasized printing	63
<ESC> "F"	Cancel emphasized printing	63
<ESC> "G"	Double-strike printing	63
<ESC> "H"	Cancel double-strike printing	63
<ESC> "J" <i>n</i>	Perform one <i>n</i> /180-inch line feed	74
<ESC> "K" <i>n1 n2 m1 m2 ...</i>	Print normal-density 8-bit graphics	80
<ESC> "L" <i>n1 n2 m1 m2 ...</i>	Print double-density 8-bit graphics	80
<ESC> "M"	Elite pitch	68
<ESC> "N" <i>n</i>	Set bottom margin	74
<ESC> "O"	Cancel bottom margin	75
<ESC> "P"	Pica pitch	68
<ESC> "Q" <i>n</i>	Set right margin	77
<ESC> "R" <i>n</i>	Select international character set	67
<ESC> "S" 0	Superscript	65
<ESC> "S" 1	Subscript	65
<ESC> "T"	Cancel superscript or subscript	65
<ESC> "U" 0	Bi-directional printing	86
<ESC> "U" 1	Uni-directional printing	86
<ESC> "W" <i>n</i>	Expanded printing	69
<ESC> "Y" <i>n1 n2 m1 m2 ...</i>	Print double-density, double-speed 8-bit graphics	80
<ESC> "Z" <i>n1 n2 m1 m2 ...</i>	Print quadruple-density 8-bit graphics	81
<ESC> "\" <i>n1 n2</i>	Relative horizontal tab	79
<ESC> "b" <i>n0 n1 n2 ...</i> <0>	Set vertical tab stops in channel	75
<ESC> "g"	Semi-condensed pitch	68
<ESC> "j" <i>n</i>	Perform one <i>n</i> /180-inch reverse line feed	74
<ESC> "k" <i>n</i>	Select LQ font	62
<ESC> "l" <i>n</i>	Set left margin	77
<ESC> "p" <i>n</i>	Proportional spacing	69
<ESC> "q" <i>n</i>	Select ornament character	64
<ESC> "t" <i>n1</i>	Select character table	66
<ESC> "w" 0	Return to normal height	71
<ESC> "w" 1	Print double-height characters	71
<ESC> "x" <i>n</i>	Select print quality	62
<FS> "3" <i>n</i>	Set line spacing to <i>n</i> /360 inch	72
<FS> "@"	Reset printer	88
<FS> "E" <i>n</i>	Select character width	70
<FS> "F"	Select forward feed mode	73
<FS> "I" 0	Select Italic character set	66
<FS> "I" 1	Select Graphics character set	67
<FS> "I" 2	Shift download character area	84
<FS> "R"	Select reverse feed mode	73
<FS> "V" 0	Return to normal height	71
<FS> "V" 1	Print double-height characters	71
<FS> "Z" <i>n1 n2 m1 m2 m3 ...</i>	Print hex-density 24-bit graphics	81
	Delete last character sent	85

CONTROL PANEL OPERATIONS

The control panel buttons can be pressed individually to perform the operations indicated by their names.

FONT BUTTON — selects the font to be printed. To change the font, set the printer off-line, then press this button repeatedly until the indicators beside the desired selection illuminate.

When this switch is pressed in on-line, the printer indicates the current status.

PITCH BUTTON — allows you to select the printing pitch. Remember that the printer must be off-line for you to do this.

PAPER FEED BUTTON — If you press and release this button while off-line, the paper will feed forward one line. If you hold the button down, the printer will perform consecutive line feeds.

If you press this button while on-line, this will alternately select and cancel the Quiet mode. When in Quiet mode, the printer will print slightly slower, but at a reduced noise level.

ON LINE BUTTON — sets the printer on-line and off-line. The status changes each time you press the button.

POWER-UP FUNCTIONS

The control panel buttons perform "special" functions if you hold them down while switching the power button on.

SELF-TEST

If the printer is turned on while the **ON LINE** button is pressed, the printer will enter the short self-test mode.

If the printer is turned on while the **PAPER FEED** button is pressed, the printer will enter the long self-test mode.

PITCH LOCK

By holding the **PITCH** button down during power-up, the print pitch can only be selected from the control panel. This prevents software interference. You will hear an acknowledging beep as power comes on.

FONT LOCK

By holding the **FONT** button during power-up, fonts can only be selected from the control panel. This prevents software interference. There will be an acknowledging beep.

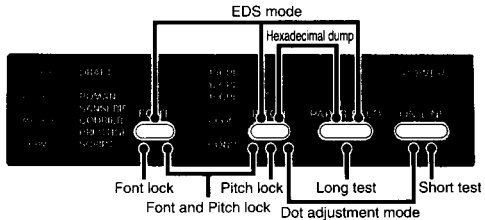

FONT AND PITCH LOCK

If you want to protect both the font and pitch settings from software changes, press both the **FONT** and **PITCH** buttons during power-up.

There will be two acknowledging beep tones.

DOT ADJUSTMENT

This mode is used to adjust the vertical alignment of text and graphics on successive bidirectional passes.

HEXADECIMAL DUMP

This feature is useful for programmers who are debugging printing programs and want to see the actual codes the printer is receiving. (Some computers change the codes the programmer intended.)

In this mode, all data received will be printed in a hexadecimal dump format, rather than the control codes being acted on as command codes.

SWITCH COMBINATION FUNCTIONS

Several additional functions can be achieved by pressing the control panel buttons in combinations.

FORM FEED

If you are using cut forms, this operation ejects the current page. If you are using fanfold forms, it feeds to the top of the next page.

PAPER PARKING

This procedure feeds the paper backward. It parks the fanfold form at the back of the printer so that you can switch to single-sheet feeding (by moving the release lever to the down position).

TOP OF FORM

When you power on the printer, the top-of-form position is automatically set to the current position. If this is not where you want the top of the page to be, you can change the top-of-form position.

MICRO-FEED

For fine alignment, you can feed the paper either forward or reverse in very small increments.

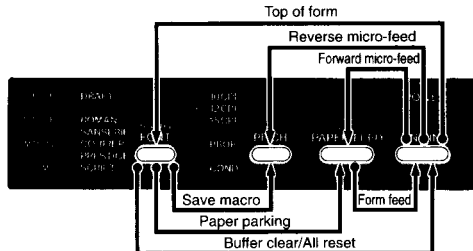

BUFFER CLEAR/ALL RESET

Press and hold the **FONT** and **ON LINE** buttons in off-line. Continue holding these two buttons down, you will hear a beep tone that the buffer is cleared. If you hold these buttons down longer, you will hear three beep tones and the printer has been initialized to the power-on default settings.

SAVE MACRO

You can save the current settings to the printer for later use with the **FONT** button and the **PITCH** button combinations.

BAIL LEVER FUNCTION

The bail lever is used to control paper.

If the paper is not mounted on the printer, use the bail lever to load the paper.

NOTE : Do not return the bail lever backward before the paper goes through under the bail lever location. The printer indicates with the beep tones to close the bail lever after the paper goes through under the bail lever location.

EDS MODE

From the control panel you can change the parameters that define how your printer works. These parameters become your power-on settings. This function is called the Electronic DIP Switch (EDS) mode.

The EDS mode in this printer has 13 functions that you can set as the power-on default.

Turn the printer on while simultaneously holding the **FONT**, **PITCH** and **PAPER FEED** buttons. You will hear an acknowledging beep as power comes on. This indicates that you have entered the EDS mode.

In EDS mode, the buttons on the control panel are used as shown below:

- Use the **FONT** button to select the Bank Letter.
- Use the **PITCH** button to select the Switch Number.
- The **ON LINE** indicator shows the current setting, ON or OFF. Use the **ON LINE** button to change the settings.
- Press the **PAPER FEED** button to print the current settings.
- Press the **PITCH** button while holding down the **FONT** button to save and exit the EDS mode.

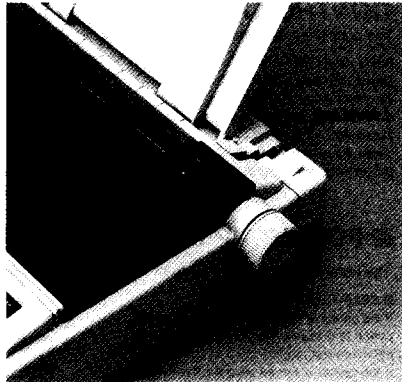

Bank/Switch	Function	ON	OFF
A-1	RAM Usage	(See Table 1)	
A-2			
A-3	Auto LF with CR	Disabled	Enabled
A-4	Auto Sheet Feeder	Not installed	Installed
A-5	Graphics Direction	Bi-directional	Uni-directional
B-1	(Not used)		
B-2	Paper-out	Enabled	Disabled
B-3	(Not used)		
B-4	(Reserved)	Leave ON	
B-5	Printable Area	Type A	Type B
C-1	Print Mode	(See Table 2)	
C-2			
C-3			
C-4	Page Length	(See Table 3)	
C-5			
D-1	Character Table	Graphics	Italics
D-2	Code page or		
D-3	International	(See Table 4 and 5)	
D-4	Character Set		
D-5	CR Centering	Disabled	Enabled
E-1			
E-2	LQ Font Selection	(See Table 6)	
E-3			
E-4	(Reserved)	Leave ON	
E-5	(Reserved)	Leave ON	

Table 1

A-1	A-2	Download	Input Buffer	Line Buffer
ON	ON	Disabled	7 K-Byte	2 Lines
OFF	ON	Disabled	16 K-Byte	1 Line
OFF	OFF	Enabled	256 Byte	1 Line

Table 2

Print Mode	C-1	C-2
10CPI DRAFT	ON	ON
17CPI DRAFT	OFF	ON
10CPI LQ	OFF	OFF

Table 3

Page Length	C-3	C-4	C-5
11 inches/Letter	ON	ON	ON
8 inches	OFF	ON	ON
11.7 inches/A4	ON	OFF	ON
12 inches	OFF	OFF	ON
8.5 inches	ON	ON	OFF
14 inches/Legal	OFF	ON	OFF
10.5 inches/Executive	ON	OFF	OFF
7.25 inches	OFF	OFF	OFF

Table 4

Code Page	D-2	D-3	D-4
#437 U.S.A.	ON	ON	ON
#850 Multi-lingual	OFF	ON	ON
#860 Portuguese	ON	OFF	ON
#861 Icelandic	OFF	OFF	ON
#863 Canadian French	ON	ON	OFF
#865 Nordic	OFF	ON	OFF

Table 5

Country	D-2	D-3	D-4
U.S.A.	ON	ON	ON
France	OFF	ON	ON
Germany	ON	OFF	ON
England	OFF	OFF	ON
Denmark I	ON	ON	OFF
Sweden	OFF	ON	OFF
Italy	ON	OFF	OFF
Spain I	OFF	OFF	OFF

Table 6

Font Name	E-1	E-2	E-3
Roman	ON	ON	ON
Sansenf	OFF	ON	ON
Courier	ON	OFF	ON
Prestige	OFF	OFF	ON
Script	ON	ON	OFF

NOTE : The factory default is **ON** for all functions except A-5 and B-5 which are set to the **OFF** position.